

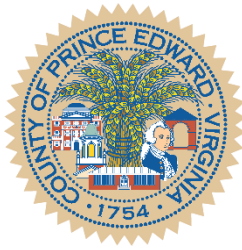

MISSION STATEMENT

"The mission of the Board of Supervisors of the County of Prince Edward is to represent all citizens, provide leadership, create vision and set policy to accomplish positive change and planned growth and to provide essential services, enhancing the quality of life and maintaining fiscal responsibility."

[This page intentionally left blank]



**BOARD OF SUPERVISORS
MEETING AGENDA**

May 9, 2023

The Prince Edward County Board of Supervisors encourages citizens participation in public meetings through in-person participation, written comments and/or remote participation by calling: **1-844-890-7777, Access Code: 390313** (*If busy, please call again.*) Additionally, citizens may view the Board meeting live in its entirety at the County’s YouTube Channel, the link to which is provided on the County’s website.

~~~~~

|           |                                                                                                                                                                                                                                                                                                         | <u>Staff Contact</u> | <u>Page #</u> |
|-----------|---------------------------------------------------------------------------------------------------------------------------------------------------------------------------------------------------------------------------------------------------------------------------------------------------------|----------------------|---------------|
| 7:00 p.m. | 1. The chair will call to order the May meeting of the Board.                                                                                                                                                                                                                                           |                      | 5             |
|           | 2. Invocation                                                                                                                                                                                                                                                                                           |                      | 5             |
|           | 3. Pledge of Allegiance                                                                                                                                                                                                                                                                                 |                      | 5             |
|           | 4. Conflict of Interest Disclosures                                                                                                                                                                                                                                                                     |                      | 7             |
|           | 5. Recognitions                                                                                                                                                                                                                                                                                         | Crystal Baker        | 9             |
|           | 6. <b><u>PUBLIC PARTICIPATION</u></b><br><i>Citizens wishing to address the Board are asked to please sign the Public Participation register prior to the beginning of the meeting.</i>                                                                                                                 |                      | 11            |
|           | 7. Board of Supervisors Comments                                                                                                                                                                                                                                                                        |                      | 13            |
|           | 8. <u>Consent Agenda:</u>                                                                                                                                                                                                                                                                               |                      |               |
|           | a. Treasurer’s Report                                                                                                                                                                                                                                                                                   |                      | 15            |
|           | b. Approval of Minutes                                                                                                                                                                                                                                                                                  |                      | 19            |
|           | c. Account & Claims, Mileage Reports, County Attorney Invoices                                                                                                                                                                                                                                          |                      | 79            |
|           | d. The County Administrator has reported that checks have been issued pursuant to the order of the Board as to salaries, etc., the amount of which has been heretofore approved.                                                                                                                        |                      | 113           |
|           | 9. <u>Highway Matters:</u>                                                                                                                                                                                                                                                                              | Sarah Puckett        | 115           |
|           | a. Authorize FY 24-29 Six-Year Plan Public Hearing                                                                                                                                                                                                                                                      |                      |               |
|           | 10. <u>Community Partner Updates:</u>                                                                                                                                                                                                                                                                   | Doug Stanley         | 117           |
|           | a. Hampden-Sydney College                                                                                                                                                                                                                                                                               |                      |               |
|           | b. Longwood University                                                                                                                                                                                                                                                                                  |                      |               |
|           | c. Town of Farmville                                                                                                                                                                                                                                                                                    |                      |               |
| 7:30 p.m. | 11. <b><u>PUBLIC HEARINGS:</u></b> The Board will receive public input on the following:                                                                                                                                                                                                                |                      |               |
|           | a. A request by Norvell Signs on behalf of Prince Edward County Public Schools for a Special Use Permit to replace three existing signs at the Prince Edward County Elementary, Middle, and High School with electronic signs on Tax Map Parcels 051-8-2 and 051-A-37 on Zion Hill Road, Farmville, VA. | Robert Love          | 119           |

|                                                                                                                                                                                                                                                                                                                                                           |                     |     |
|-----------------------------------------------------------------------------------------------------------------------------------------------------------------------------------------------------------------------------------------------------------------------------------------------------------------------------------------------------------|---------------------|-----|
| b. Pursuant to Section 15.2-2507 of the <i>Code of Virginia</i> , the Board will consider amendments to the FY 23 County Budget and FY 23 County School Budget and accept the distribution of \$949,999.64 of Federal Coronavirus Relief Funds to be appropriated by the Board of Supervisors and distributed to the Prince Edward County Public Schools. | Cheryl Stimpson     | 173 |
| 12. <u>Department Updates:</u>                                                                                                                                                                                                                                                                                                                            |                     | 183 |
| a. Department of Social Services                                                                                                                                                                                                                                                                                                                          | Kimberly Allen      |     |
| b. Economic Development & Tourism                                                                                                                                                                                                                                                                                                                         | Chelsey White       |     |
| 13. Appointments                                                                                                                                                                                                                                                                                                                                          | Sarah Puckett       | 185 |
| 14. Zoning Ordinance, Appendix B Amendment                                                                                                                                                                                                                                                                                                                | Robert Love         | 189 |
| 15. Comprehensive Plan Consulting Contract                                                                                                                                                                                                                                                                                                                | Robert Love         | 321 |
| 16. 2025 Reassessment Contract                                                                                                                                                                                                                                                                                                                            | Doug Stanley        | 361 |
| 17. Sandy River Reservoir – PPEA Comprehensive Agreement                                                                                                                                                                                                                                                                                                  | Doug Stanley        | 425 |
| 18. <u>Finance &amp; Human Resources Report:</u>                                                                                                                                                                                                                                                                                                          | Cheryl Stimpson     |     |
| a. Appropriations – IDA (Reinvestment Grants)                                                                                                                                                                                                                                                                                                             |                     | 577 |
| b. Appropriation – Sheriff’s Department (NRA Grant)                                                                                                                                                                                                                                                                                                       |                     | 579 |
| 19. County Attorney’s Report                                                                                                                                                                                                                                                                                                                              | Terri Atkins Wilson | 583 |
| 20. County Administrator’s Report                                                                                                                                                                                                                                                                                                                         | Doug Stanley        | 585 |
| 21. <u>Correspondence/Informational</u>                                                                                                                                                                                                                                                                                                                   |                     | 587 |
| a. SVCC, The Proud Panther                                                                                                                                                                                                                                                                                                                                |                     | 588 |
| 22. <u>Monthly Reports</u>                                                                                                                                                                                                                                                                                                                                |                     | 598 |
| a. Animal Control                                                                                                                                                                                                                                                                                                                                         |                     | 599 |
| b. Building Office                                                                                                                                                                                                                                                                                                                                        |                     | 600 |
| c. Commonwealth Regional Council                                                                                                                                                                                                                                                                                                                          |                     | 601 |

*(NOTE: Additional agenda items may be added to the Table Pack is available for review after 4:30 p.m. on May 9, 2023.)*



**Board of Supervisors  
Agenda Summary**

**Meeting Date:** May 9, 2023  
**Item #:** 1, 2, 3  
**Department:** Board of Supervisors  
**Staff Contact:** Douglas P. Stanley / Sarah Elam Puckett  
**Agenda Item:** Call to Order, Invocation, Pledge of Allegiance, Remote Participation

**SUMMARY:**

1. **Call To Order:** Board Chairman Gilliam will call to order the May meeting of the Prince Edward Board of Supervisors.
2. **Invocation**
3. **Pledge of Allegiance**

**COST:**

**ATTACHMENTS:**

**RECOMMENDATION:**

**SAMPLE MOTION:**

Motion \_\_\_\_\_ Cooper-Jones \_\_\_\_\_ Gilliam \_\_\_\_\_ Pride \_\_\_\_\_  
Second \_\_\_\_\_ Emert \_\_\_\_\_ Jenkins \_\_\_\_\_ Townsend \_\_\_\_\_  
Jones \_\_\_\_\_ Watson \_\_\_\_\_

**[This page intentionally left blank]**

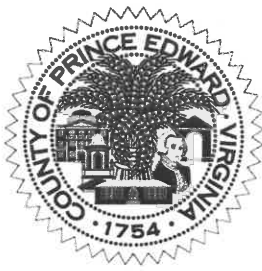

**Board of Supervisors  
Agenda Summary**

**Meeting Date:** May 9, 2023  
**Item #:** 4  
**Department:** Board of Supervisors  
**Staff Contact:** Douglas P. Stanley / Sarah Elam Puckett  
**Agenda Item:** Conflict of Interest Act Disclosures

---

**SUMMARY:**

The Chair will ask if any member of the Board of Supervisors has a conflict or disclosure regarding any item pending before the Board of Supervisors, per the requirements of the *Virginia State and Local Government Conflict of Interests Act*. A disclosure form is attached, if needed.

**COST:**

**ATTACHMENTS:**

**RECOMMENDATION:**

**SAMPLE MOTION:**

Motion \_\_\_\_\_  
Second \_\_\_\_\_

Cooper-Jones \_\_\_\_\_  
Emert \_\_\_\_\_

Gilliam \_\_\_\_\_  
Jenkins \_\_\_\_\_  
Jones \_\_\_\_\_

Pride \_\_\_\_\_  
Townsend \_\_\_\_\_  
Watson \_\_\_\_\_



**STATEMENT OF DISCLOSURE**

**DECLARATION OF INTEREST**

1. Transaction Under Discussion/Consideration: \_\_\_\_\_

\_\_\_\_\_  
\_\_\_\_\_

2. Nature of Public Official's Personal Interest Affected by the Transaction: \_\_\_\_\_

\_\_\_\_\_  
\_\_\_\_\_

3. Identify Membership in Business, Profession, Occupation or Group of Members that are Affected by the Transaction: \_\_\_\_\_

\_\_\_\_\_  
\_\_\_\_\_  
\_\_\_\_\_

4. I do hereby certify and declare that I am able to participate in the above identified transaction fairly, objectively and in the public interest: Yes \_\_\_\_\_ No \_\_\_\_\_

Signature: \_\_\_\_\_ Date: \_\_\_\_\_

**DECLARATION OF ACCURACY**

I, the undersigned, certify that all statements in this statement of disclosure are true and correct to the best of my knowledge, are accurate and complete, and include all information required by the *Virginia Conflict of Interest Act*, Title 2.2, Chapter 31, of the *Code of Virginia*.

Signature: \_\_\_\_\_ Date: \_\_\_\_\_

Print Name \_\_\_\_\_

Address \_\_\_\_\_

\_\_\_\_\_





**Board of Supervisors  
Agenda Summary**

**Meeting Date:** May 9, 2023  
**Item #:** 5  
**Department:** Human Resources  
**Staff Contact:** Crystal Baker  
**Agenda Item:** Recognitions

---

**Summary:** Recognitions” is an opportunity for the Board of Supervisors to recognize achievements in our community, with a focus on the accomplishments of students, employees and our citizen volunteers who serve the County of Prince Edward.

At its May meeting, the Board will have the opportunity to recognize two county employees:

1. Employee of the Month: The May Employee of the Month is Adam Mumma. Adam was nominated and is being recognized for his work as a member of the Buildings & Grounds staff. Rain, shine, cold or hot . . . he was front and center ready to get the job done with a smile. No job was too big or too small for Adam. “He always seems happy to help with anything!! His attitude and hardworking habits make him a real asset to have around.” The County is fortunate to have employees like Adam, who has now been transferred and promoted to the position of Chief Animal Control Officer. We are confident that Adam will bring his great work ethic and can-do attitude to his new position.
  
2. Retirement: The Board would also like to take this opportunity to congratulate Sarah Trent on her retirement. The dedication she has shown over the last twenty-six years to Prince Edward County is appreciated beyond measure! We wish Sarah all the best.

**Attachments:**

**Recommendation:**

**SAMPLE MOTION:**

|              |                    |               |                |
|--------------|--------------------|---------------|----------------|
| Motion _____ | Cooper-Jones _____ | Gilliam _____ | Pride _____    |
| Second _____ | Emert _____        | Jenkins _____ | Townsend _____ |
|              |                    | Jones _____   | Watson _____   |

**[This page intentionally left blank]**



**Board of Supervisors  
Agenda Summary**

**Meeting Date:** May 9, 2023  
**Item #:** 6  
**Department:** Board of Supervisors  
**Staff Contact:** Douglas P. Stanley / Sarah Elam Puckett  
**Agenda Item:** Public Participation

**SUMMARY:** *Public Participation is a time set aside for citizens to share their thoughts, ideas and concerns. An official record is made of each person’s contribution tonight and will be directed to the County Administrator for follow-up; any necessary follow-up will be noted and tracked. Follow-up may consist of an immediate response, or planned action by the County Administrator or Board, or by placement on a future Board agenda. Tonight’s agenda cannot be changed, because the public needs advance knowledge of and the opportunity to review related materials regarding items addressed by the Board. To further assist public information, the Board requests our Administrator, Attorney or county staff to immediately correct any factual error that might occur.*

**OPPORTUNITIES FOR PUBLIC PARTICIPATING & PUBLIC INPUT**

Public Participation and Public Hearing comments for County meetings will be received by Karin Everhart, Deputy Clerk to the Board of Supervisors, using one the following methods:

1. **Written Comments:** Please limit word count to no more than 500 words. Comments must be received by 2:00 p.m. the day of the meeting.

- a. **Mailed:** Board of Supervisors  
P.O. Box 382, Farmville, VA 23901.
- b. **E-Mailed:** Board of Supervisors: [board@co.prince-edward.va.us](mailto:board@co.prince-edward.va.us)  
Planning Commission: [info@co.prince-edward.va.us](mailto:info@co.prince-edward.va.us)

2. **Verbal Comments:** Citizens may also participate remotely during the meeting. Using the meeting call-in information provided, citizens may **phone-in to the meeting and provide comments during the Public Participation/Public Hearing portion of the agenda;** however, **citizens must pre-register** with the County Administrator’s Office at 434-392-8837 **by 2:00 p.m. the day of the meeting.** Callers must be on the line and ready to speak when called upon by the Chair. Please state your name and district of residence. Based upon the # of pre-registered speakers, the Chair will determine the time allotted to each speaker.

**Attachments:** Public Participation Tracking Form

**Recommendation:** None.

|              |                    |               |                |
|--------------|--------------------|---------------|----------------|
| Motion _____ | Cooper-Jones _____ | Gilliam _____ | Pride _____    |
| Second _____ | Emert _____        | Jenkins _____ | Townsend _____ |
|              |                    | Jones _____   | Watson _____   |

# PUBLIC INPUT TRACKING LOG

| ITEM NUMBER | CITIZEN REMARK | REMARK DATE | REPEAT REMARK | STATUS |
|-------------|----------------|-------------|---------------|--------|
| 1           |                |             | Y N           |        |
| 2           |                |             |               |        |
| 3           |                |             |               |        |
| 4           |                |             |               |        |
| 5           |                |             |               |        |
| 6           |                |             |               |        |
| 7           |                |             |               |        |
| 8           |                |             |               |        |
| 9           |                |             |               |        |
| 10          |                |             |               |        |
| 11          |                |             |               |        |
| 12          |                |             |               |        |
| 13          |                |             |               |        |
| 14          |                |             |               |        |



**Board of Supervisors  
Agenda Summary**

**Meeting Date:** May 9, 2023  
**Item #:** 7  
**Department:** Board of Supervisors  
**Staff Contact:** Douglas P. Stanley / Sarah Elam Puckett  
**Agenda Item:** Board of Supervisors Comments

---

**SUMMARY:**

The Board has set aside ten minutes for Board members to respond to citizen input from Public Participation.

**Cost:**

**Attachments:**

**Recommendation:** None.

**Sample Motion:**

Motion \_\_\_\_\_  
Second \_\_\_\_\_

Cooper-Jones \_\_\_\_\_  
Emert \_\_\_\_\_

Gilliam \_\_\_\_\_  
Jenkins \_\_\_\_\_  
Jones \_\_\_\_\_

Pride \_\_\_\_\_  
Townsend \_\_\_\_\_  
Watson \_\_\_\_\_

**[This page intentionally left blank]**



**Board of Supervisors  
Agenda Summary**

**Meeting Date:** May 9, 2023  
**Item #:** 8-a  
**Department:** Board of Supervisors  
**Staff Contact:** Donna Nunnally  
**Agenda Item:** Treasurer's Report

---

**SUMMARY:**

The Treasurer's Report is attached.

**Cost:**

**Attachments:** Treasurer's Report

**Recommendation:** Approval.

**Sample Motion:**

Motion \_\_\_\_\_  
Second \_\_\_\_\_

Cooper-Jones \_\_\_\_\_  
Emert \_\_\_\_\_

Gilliam \_\_\_\_\_  
Jenkins \_\_\_\_\_  
Jones \_\_\_\_\_

Pride \_\_\_\_\_  
Townsend \_\_\_\_\_  
Watson \_\_\_\_\_

**Prince Edward Board of Supervisors Treasurer's Report  
March 2023**

| Bank Account Balances         |       |           |  |  |                  |  |                         |
|-------------------------------|-------|-----------|--|--|------------------|--|-------------------------|
| Name of Bank                  | Ref # | Int. Rate |  |  | Bank Balance     |  | Available Balance       |
| Benchmark Pooled Fund Account | 7654  |           |  |  | \$ 19,299,237.18 |  | \$ 19,299,237.18        |
| Benchmark Social Services     | 9746  |           |  |  | \$ 245,706.44    |  | \$ 245,706.44           |
| Benchmark School Fund         | 3352  |           |  |  | \$ 2,208,211.38  |  | \$ 2,208,211.38         |
| Benchmark Food Service        | 3742  |           |  |  | \$ 614,225.25    |  | \$ 614,225.25           |
| <b>TOTAL</b>                  |       |           |  |  |                  |  | <b>\$ 22,367,380.25</b> |

\*Note: School Fund and Cafeteria Fund balances shown above are estimated balances.

| Certificates of Deposit            |       |           |      |          |                 |  |                         |
|------------------------------------|-------|-----------|------|----------|-----------------|--|-------------------------|
|                                    | Ref # | Int. Rate | Term | Maturity | Bank Balance    |  | Available Balance       |
| <b>Benchmark</b>                   |       |           |      |          |                 |  |                         |
|                                    | 0994  | 1.00      | 24   | 01/15/26 | \$ 122,584.08   |  |                         |
|                                    | 0995  | 1.00      | 24   | 01/15/26 | \$ 122,584.08   |  |                         |
| Recreation Fund                    | 0998  | 0.50      | 36   | 02/14/24 | \$ 17,529.72    |  |                         |
| Benchmark 5 Yr CD-letter of credit | 0632  | 1.00      | 60   | 01/04/26 | \$ 663,114.32   |  | \$ 925,812.20           |
| Benchmark Investment Acct          | L796  | 3.35      | 36   | 05/13/25 | \$ 2,457,133.19 |  | \$ 2,457,133.19         |
| <b>Farmers Bank</b>                |       |           |      |          |                 |  |                         |
|                                    | 2465  | 0.50      | 36   | 06/17/24 | \$ 110,040.90   |  |                         |
|                                    | 2466  | 0.50      | 36   | 06/17/24 | \$ 110,040.90   |  |                         |
| Underground Storage                | 2478  | 0.60      | 36   | 10/27/24 | \$ 22,973.65    |  |                         |
|                                    | 2501  | 2.09      | 36   | 08/19/25 | \$ 2,248,691.19 |  |                         |
|                                    | 3418  | 3.75      | 6    | 05/16/23 | \$ 2,500,000.00 |  |                         |
|                                    | 3438  | 4.95      | 6    | 08/16/23 | \$ 2,520,827.78 |  | \$ 7,512,574.42         |
| <b>TOTAL</b>                       |       |           |      |          |                 |  | <b>\$ 10,895,519.81</b> |

**GRAND TOTAL**

**\$ 33,262,900.06**



**Prince Edward Board of Supervisors Treasurer's Report - March 2022**

| <b>Name of Bank</b>                | <b>Bank Balance</b> |  |  | <b>Available Balance</b> |
|------------------------------------|---------------------|--|--|--------------------------|
| Benchmark Pooled Fund Account      | \$ 22,091,677.11    |  |  | \$ 22,091,677.11         |
| Benchmark Social Services          | \$ 201,684.19       |  |  | \$ 201,684.19            |
| Benchmark School Fund              | \$ 1,851,990.49     |  |  | \$ 1,851,990.49          |
| Benchmark Food Service             | \$ 395,076.41       |  |  | \$ 395,076.41            |
| <b>TOTAL</b>                       |                     |  |  | <b>\$ 24,540,428.20</b>  |
|                                    |                     |  |  |                          |
|                                    |                     |  |  |                          |
| <b>Certificate of Deposits</b>     |                     |  |  |                          |
| Benchmark                          |                     |  |  | \$ 628,007.42            |
| Farmers Bank                       |                     |  |  | \$ 4,471,866.32          |
| Benchmark 5 Yr CD-letter of credit |                     |  |  | \$ 656,524.41            |
| <b>TOTAL</b>                       |                     |  |  | <b>\$ 5,756,398.15</b>   |
|                                    |                     |  |  |                          |
|                                    |                     |  |  |                          |
| <b>GRAND TOTAL</b>                 |                     |  |  | <b>\$ 30,296,826.35</b>  |

**[This page intentionally left blank]**

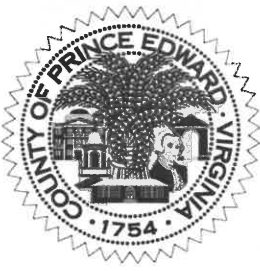

**Board of Supervisors  
Agenda Summary**

**Meeting Date:** May 9, 2023  
**Item #:** 8-b  
**Department:** Board of Supervisors  
**Staff Contact:** Karin Everhart  
**Agenda Item:** Approval of Minutes

---

**SUMMARY:**

Attached are draft minutes for the Board’s review and approval.

**Cost:**

**Attachments:** Board minutes.

**Recommendation:** Approval.

**Sample Motion:**

Motion \_\_\_\_\_  
Second \_\_\_\_\_

Cooper-Jones \_\_\_\_\_  
Emert \_\_\_\_\_

Gilliam \_\_\_\_\_  
Jenkins \_\_\_\_\_  
Jones \_\_\_\_\_

Pride \_\_\_\_\_  
Townsend \_\_\_\_\_  
Watson \_\_\_\_\_

April 11, 2023

At the regular meeting of the Board of Supervisors of Prince Edward County, held at the Court House, thereof, on Tuesday, the 11<sup>th</sup> day of April, 2023; at 7:00 p.m., there were present:

Pattie Cooper-Jones  
J. David Emert  
Llew W. Gilliam, Jr.  
Victor "Bill" Jenkins  
E. Harrison Jones  
Odessa H. Pride  
Jerry R. Townsend  
Cannon Watson

Also present: Douglas P. Stanley, County Administrator; Sarah Elam Puckett, Assistant County Administrator; Chelsey White, Director of Economic Development and Tourism; Terri Atkins Wilson, County Attorney; Scott Frederick, PE, VDOT Resident Engineer; Scott Davis, Farmville Town Manager; and Dr. Barbara Johnson, Superintendent, Prince Edward County Public Schools.

Chairman Gilliam called the April meeting to order.

Supervisor Cooper-Jones offered the invocation and led the Pledge of Allegiance.

In Re: Conflict of Interest Act

(None)

In Re: Recognitions

"Recognitions" is an opportunity for the Board of Supervisors to recognize achievements in our community, with a focus on the accomplishments of students, employees and our citizen volunteers who serve the County of Prince Edward.

Mrs. Cheryl Stimpson, Director of Finance, stated the Board would like to recognize Stephanie Bappert as Employee of the Month for April. "Mrs. Bappert has worked in the Treasurer's office for over 17 years. She goes above and beyond to make herself available to assist other departments. Her "get the job done" mentality keeps everyone on their toes and her generous spirit is unmatched. Stephanie has been and continues to be an asset to Prince Edward County!"

In Re: Public Participation

*Public Participation is a time set aside for citizens to share their thoughts, ideas and concerns. An official record is made of each person's contribution tonight and will be directed to the County Administrator for follow-up; any necessary follow-up will be noted and tracked. Follow-up may consist of an immediate response, or planned action by the County Administrator or Board, or by placement on a future Board agenda. Tonight's agenda cannot be changed, because the public needs advance knowledge of and the opportunity to review related materials regarding items addressed by the Board. To further assist public information, the Board requests the Administrator, Attorney or county staff to immediately correct any factual error that might occur.*

Howard Armistead, Farmville, presented statistics and information on COVID-19; he stated the epidemic isn't over and it is not likely to go away entirely. He said Prince Edward County is in the bottom 10% for vaccination rates in the state, with a 30% higher mortality rate comparable to the state of Virginia as a whole. He stated he has written two books on the topic.

Sheriff Tony Epps stated that on Friday, a citizen was reported as missing in the Leigh District. He said that thanks to Trey Pyle operating the drone, the citizen was found in about one hour.

Krystal Hochstetler, Prospect District, expressed her concerns about the increasing number of utility scale energy facilities that have been approved in Prince Edward County. She said she expressed her concerns at the most recent Prince Edward County Planning Commission meeting. She said she is concerned for the future of the agricultural and forestal zoned land, the due process of these facilities and the driving force behind them, the pay-to-play politics, and what happens at the end of these facilities' life expectancies. She stated the current Zoning Ordinance states the current alternative energy facility size regulation states that "in no case shall any energy facility exceed 2,513 acres." She said at the Planning Commission meeting, Chairman Prengaman stated Prince Edward County was not a solar county, and if that is the case, the County should revise the County's ordinance to reduce the number of contiguous acres that the facility can inhabit. She said the loss of carbon-sequestering land will harm our carbon emission goals. She said solar facilities can create land disturbances, create soil compaction, increased runoff and erosion issues. She continued by stating that according to USDA data, Virginia lost about 2,000 acres of productive farmland per week in 2021 due to various reasons; solar facilities are posing a large threat to Virginia's agricultural land. There are now over 50 utility-sized facilities in Virginia, according to the Department of Energy. She reviewed the revenue share aspect of solar energy to localities, and questioned the decommissioning process. She asked how much of the County's agricultural land is the Board willing to "sign off" and what is the County's land use objective.

Steve Hochstetler, Prospect District, said he has been here 40 years and has concerns about the loss of agriculture and farmland. He asked how solar farms fit into the agriculture and the Comprehensive Plan, and stated that the State Comprehensive Plan states that there can be no more than 5.5% of acreage in a five-mile radius allowed [to have solar facilities]. He expressed concerns about erosion problems at an existing solar project. He encouraged the Board to set up an overall plan for the future for agriculture and jobs in the County. He thanked the Board for the time to speak and for their leadership.

In Re: Board Comments

The Board expressed congratulations to Sarah Trent for her 26 years of service to Prince Edward County, and to the boys and girls' basketball teams for their accomplishments; they thanked all in attendance for coming out.

Supervisor Jones thanked the Hochstetlers for their input and forward-thinking; he said he means no ill will to the solar [companies] as they are seeking solutions responsibly with today's best interest in mind, and tomorrow's. He said he will keep that in mind as they discuss the [update to the] Comprehensive Plan. He thanked all for attending.

Supervisor Cooper-Jones welcomed all in attendance;

Supervisor Pride welcomed all and said she understands the views of the farmers and thanked all for coming.

Supervisor Jenkins said people need to come express their concerns and thanked all for coming.

Supervisor Watson thanked everyone for expressing their concerns.

Supervisor Townsend welcomed all.

Supervisor Emert agreed with the previous Board members; he said he understands this is a sensitive issue.

Chairman Gilliam said he was glad of the attendance; he said he has taken time to try to consider all aspects of the solar issue. He said the Board will study this and make the best decision that they can.

In Re: Public Hearing – Special Use Permit, Storage Shed Manufacturing & Retail (Boehmer)

Chairman Gilliam announced that this was the date and time scheduled for a public hearing to receive citizen input prior to considering a request by Tim Boehmer for a Special Use Permit to operate a storage shed manufacturing and retail facility on Tax Map Parcel 018-A-32 at 5865 Prince Edward Highway, Prospect, Virginia. Notice of this hearing was advertised according to law in the Wednesday, March 29, 2023, and Wednesday, April 5, 2023 editions of THE FARMVILLE HERALD, a newspaper published in the County of Prince Edward.

Mr. Love stated the County has received an application for a Special Use Permit from Tim Boehmer for a Special Use Permit to operate a storage shed manufacturing and retail facility on Tax Map Parcel 018-A-32 at 5865 Prince Edward Highway, Prospect, VA., which is zoned A-1, Agricultural Conservation.

The purpose of the Special Use is to allow for the location of a storage shed manufacturing and retail facility. The applicant stated that all operations related to the construction and painting of sheds will take place indoors. The new building will be a 100' x 100' manufacturing facility and use the existing building as an office. The applicant is proposing a 40 square foot pole sign and a 64 square foot building sign. Both sign types are allowed in the Zoning District per Section 3-104.5 (3). However, it has been the practice in recent Special Use Permit applications to limit site signage to a monument type. Section 3-104.5 (2) provides for "*Monument signs not exceeding four feet in height and 24 square feet in size, not more than one per business operation.*" Please note that the sign drawings most recently provided by the applicant depict signage significantly smaller than what is shown on the actual site plan itself and is well within signage regulations.

The Planning Commission held a public hearing on March 21 2023; no one spoke in opposition of the application and the County has received no correspondence opposing the request. The Planning Commission recommended approval with 19 conditions, forwarding the request to the Board of Supervisors for Public Hearing. Mr. Love stated that a list of updated Potential Conditions as recommended by the Planning Commission has been provided for the Board's review.

County staff is of the opinion the use is generally compatible with the zoning district and will have minimal impacts on surrounding properties as far as traffic and noise.

Chairman Gilliam opened the public hearing.

Tim Boehmer requested the Board consider the hours of operation as 6:00 a.m. to 6:00 p.m. as all manufacturing is done inside the building. He said the building location has been adjusted to the front of the property due to concerns; this would also be beneficial due to [the noise of] maintenance on equipment. He asked that the hours of receiving be set as 8:00 a.m. to 5:00 p.m., and Saturday hours be set as 7:00 a.m. to 5:00 p.m.

Discussion followed on noise concerns.

Supervisor Watson questioned the number of employees; Mr. Boehmer stated there are expected to be 20 to 30 employees. Mr. Boehmer added that there is a natural buffer of trees around the property and the 100' x 100' steel building is insulated.

Nathaniel Boehmer stated they currently have two manufacturing operations now, located in Prospect and Cumberland County, with 24 employees.

There being no one further wishing to speak, Chairman Gilliam closed the public hearing.

Supervisor Emert referenced Condition #16 regarding the building materials and trash containers and their need to be screened and to put up a fence. Mr. Love said that a fence is required if they have outdoor storage, or manufacturing outside, or visible from the road or adjacent property owner; Mr. Love said this is included in the Conditions and the applicants are aware. Mr. Love said this does not include the finished buildings.

Supervisor Cooper-Jones made a motion, seconded by Supervisor Townsend, to approve the Special Use Permit request by Tim Boehmer for a storage shed manufacturing and retail facility with the following conditions, to include the amended hours of operation; the motion carried:

|      |                       |           |
|------|-----------------------|-----------|
| Aye: | Pattie Cooper-Jones   | Nay: None |
|      | J. David Emert        |           |
|      | Llew W. Gilliam, Jr.  |           |
|      | Victor "Bill" Jenkins |           |
|      | E. Harrison Jones     |           |
|      | Odessa H. Pride       |           |
|      | Jerry R. Townsend     |           |
|      | Cannon Watson         |           |

**Special Use Permit – Tim Boehmer  
Tax Parcel Map #: 018-A-32  
CONDITIONS**

**SITE PLAN**

1. Development activities on the site shall be limited to those as specified in the Special Use Permit Application and Site Plan. The final locations of incidental facilities may be adjusted provided no such adjustment violates any buffers, setbacks, or other statutory requirement. The concepts reflected in the filed special use permit dated 2/15/2023 are hereby made part of these development conditions.
2. Final site plan approval for the Storage Shed Manufacturing & Retail Facility shall be submitted to the Prince Edward County Community Development Department for final review and approval pursuant to Appendix B of the Prince Edward County Code (Zoning Ordinance).
3. Any proposed expansion of the operation, change of activities or additional facilities or activities shall be submitted to the Prince Edward County Planning and Community Development office for review prior to implementation. Any changes may be subject to Permit amendment procedures, including Public Hearings.
4. All buildings within the property shall be developed as a cohesive entity ensuring that building placement, architectural treatment, parking lot lighting, landscaping, trash disposal, vehicular and pedestrian circulation and other development elements work together functionally and aesthetically.



5. All landscaping shall be mulched and maintained to the reasonable satisfaction of the Prince Edward County Planning and Community Development Director. Any vegetation found to be of poor condition shall be replaced and/or improved at the reasonable direction of the Planning and Community Development Director or his designee.

#### **ENVIRONMENTAL**

6. All pollution control measures, erosion and sediment control measures, storm water control facilities, and all construction activities shall comply with the requirements of the appropriate federal, state, and local regulations and ordinances.
7. All facilities for the provision of potable water and sanitation and wastewater disposal systems shall be approved by the appropriate local, state, or federal agency including but not limited to Virginia Department of Health, Virginia Departments of Environmental Quality, Environmental Protection Agency, etc.
8. Any development activities of a structural or land disturbing nature not specifically addressed by these Conditions shall be in conformance with applicable provisions of federal, state, and local statutes and regulations.

#### **TRANSPORTATION**

9. All entrance permits must be authorized by the Virginia Department of Transportation.
10. All internal roads used for public access shall be of compacted earth or have a minimum of a four (4) inch stone base and shall be paved with concrete, asphalt, or durable pervious paving material.
11. Adequate area shall be provided on site to accommodate parking of all employees and patrons. It shall be the responsibility of the Permittee to assure that employees and patrons park only on site and not on any highway right-of-way, or on adjoining or adjacent parcels unless written consent is provided by the owner or owners thereof.
12. No storage shed building may be located closer than 10 feet from any property line nor be placed within VDOT right-of-way.

#### **GENERAL**

13. Hours of operation shall be limited to Monday through Friday 6 a.m. to 6 p.m. and Saturday 7 a.m. to 5 p.m. No Sunday operations are permitted.
14. Site signage shall be limited to a monument and storefront sign, as specified in Appendix B – Zoning, Section 3-104.5 (2) and Section 3-104.5 (3).
15. All exterior lighting shall be designed and installed so as to minimize glare onto adjoining properties or any public access road. All lighting shall be full cut-off type fixtures.
16. Outdoor storage of building materials and trash containers shall be situated at the rear of buildings and shall be appropriately screened per Prince Edward Zoning Ordinance, Section 4-200.15.
17. The Permittee is responsible for the appearance of the site including litter pick-up and other orderly site appearance.
18. This Permit is non-transferable, except and unless written notice from the Permittee regarding the transfer, and a signed document from the proposed new Permittee is received by the Planning and Community Development Office which states that the new Permittee agrees to comply with all terms and Conditions imposed with the original Permit Issuance. If the proposed new Permittee desires to amend the original Permit

Conditions, amendments must be addressed by the Prince Edward County Planning Commission and Board of Supervisors through the Special Use Permit process.

19. Failure of Permittee to full conform to all terms and conditions may result in revocation of this Special Use Permit if said failure or failures are not corrected or addressed to the satisfaction, not to be unreasonably withheld, of the County within thirty (30) days of written notice from the County.

In Re: Public Hearing – Special Use Permit, Elam Road Solar, LLC, Community Solar Energy Facility

Chairman Gilliam announced that this was the date and time scheduled for a public hearing to receive citizen input prior to considering a Special Use Permit request to construct and operate a 3MWac Community Solar Energy Facility on a 33-acre portion of Tax Map Parcel 031-A-16, containing a total of 136+/- acres. Notice of this hearing was advertised according to law in the Wednesday, March 1, 2023, and Wednesday, March 8, 2023 editions of THE FARMVILLE HERALD, a newspaper published in the County of Prince Edward.

Mr. Love stated the County has received an application for a Special Use Permit from Elam Road Solar LLC to construct and operate a 3MWac community solar energy facility on a 33-acre portion of Tax Map Parcel 031-A-16, containing a total of 136+/- acres, which is zoned A-1, Agricultural Conservation.

The purpose of the Special Use is to allow for the location of a community solar energy generation facility. The applicant stated that the proposed facility will not be seen nor heard and will not impact adjacent properties. The facility will not generate noise, light, dust, odor, fumes, or vibrations. Water quality will be addressed according to Virginia Stormwater Management Permit requirements and the site will not generate any significant amount of traffic with the main traffic occurring temporarily during the construction phase.

The Planning Commission held a public hearing on March 21, 2023; two residents spoke in opposition of the application and the County received one letter of opposing the request. The Planning Commission recommended approval with conditions, forwarding the request to the Board of Supervisors for Public Hearing. Mr. Love provided a list of updated Potential Conditions as recommended by the Planning Commission; he stated there are 43 conditions proposed on this community solar project.

County staff is of the opinion the use is generally compatible with the zoning district and will have minimal impacts on surrounding properties as far as traffic and noise.

John Townsend, Senior Developer, Permitting Lead, Elam Road Solar, reviewed the project overview highlighting the benefits to the County and the project's consistency with the Comprehensive Plan. He stated this

project would use a small portion of the entire parcel, and will be screened, create no noise or traffic. Mr. Townsend stated there is an existing access road that will be used and this will interconnect to the existing distribution line on Elam Road. Because of the small size of the project, there is no need for a large substation. He said community meetings were held and there was no opposition to the project. He thanked the Hostetlers for voicing their concerns.

Mr. Townsend stated if this project is approved, it will need to go through all of the normal processes such as the full site plan process with erosion and sediment control. He said that setbacks will be maintained at a greater density than current requirements set forth; there will be additional screening along Elam Drive. Environmental protections will continue.

Mr. Townsend said if approved, and once all approvals are received, this project would take four to six months to construct and would likely start in 2024-2025. There will be minimal construction traffic limited to Monday through Saturday, during daylight hours. Decommissioning is at the expense of the project owner, and all structures will be removed and recycled or repurposed. He stated this community solar project is a subscriber-based program for low-income or for those that are not able to have renewable energy on their own property. The facility will produce clean, reliable electricity.

Chairman Gilliam asked if there will be anything under the panels. Mr. Townsend said there will be grass under the panels.

Supervisor Jones asked the expected life span of the project and inquired if they have completed a decommissioning plan. Mr. Townsend replied that it is expected to have a life span of 40 years; he stated they have not done a complete decommissioning, but they have recycled panels before. Mr. Townsend added the decommissioning plan will include a bond or security which provides protections at the County and state levels.

Supervisor Emert questioned the amount of houses will be served by this 3MWac project. Mr. Townsend stated it is enough to service 500-600 houses.

Supervisor Jenkins asked how many of these projects has Elam Road Solar/Sun Tribe built. Mr. Townsend said there are eight to ten in progress and several projects over the past 15 years.

Chairman Gilliam opened the public hearing.

James Coleman, Prospect District, stated he takes farming seriously but supports this project. He said only 33 acres of the 136 acre tract of land will be used for this project; the area was most recently planted with pine and they are not losing valuable farmland. He said the remaining acres are wooded. This project will provide an annual

income; he said he used to raise soybeans and corn, and another farmer used the land, but he plans to retire. He added that the community continues to need electricity and this is a small project.

Mr. Coleman said he is glad to see there are checks and balances on the projects; he added he will plant crimson clover for the honeybees.

Chairman Gilliam questioned what type of controls are in place to manage a system failure in the event of a storm. Mr. Townsend said the site is monitored for safety issues with significant safety protocols in place. If the power grid were to fail, it would be disconnected automatically so the linemen can work on the lines.

Trevor Francis, Vice President of Engineering, Sun Tribe, stated that if there is a power loss, the site is tripped off from the grid and isolated.

Nate Boehmer, Elam Road Solar, stated he owns property to the west of the proposed solar project; he asked how many jobs this will bring to the county. He stated it will be an eyesore and asked how many solar fields have been built that the landowner lives on that property.

Krystal Hochstetler, Prospect District, presented the definition of a community facility from the Prince Edward County Code of Ordinances, Article 7, Section 7-102, as “a small scale energy facility is 200 kw or less, a large scale facility is greater than 200 kw and less than 999 kw, and a utility scale facility is 1 MW or greater.” She said there is no such things as a “community solar facility.”

Mr. Love stated the *Code of Virginia* defines what a Community Solar Program is, and in the *Code of Virginia*, that sets up a subscriber program which is treated differently in [the] Code than a utility scale. He said the utility scale can be all of those sizes, but a community project goes into the subscriber field through distribution lines and right to a standard pole, rather than to a substation with big transformers. It is different in how these programs are run; anyone that is a Dominion customer can subscribe to that program to lower their energy bill and that’s what these type of facilities do. Mr. Love said there a few of these in the County and only one that is true utility scale.

Jacob Carasella, Energy Right, stated he and his colleagues travel to educate citizens that Virginia is a significant importer of energy from our neighboring states; he said Prince Edward County has reaped the benefits of solar [energy] the right way. He said the ordinance provides strong design standards, setbacks and buffers, and decommissioning rules, all hallmarks of good policy. He commended Mr. Love and Mr. Stanley on their leadership and their economic approach to unleash the economic potential of Prince Edward County. He thanked the Board members, County staff and community leaders for leading by example. He asked the County leaders to judge the

individual solar project applications and developers on the merits of each project. He said they encourage community engagement, and he stated he understands that these developers have done a good job in communicating with the citizens. He then stated the South Central Virginia Business Alliance, a new organization that formed in 2022 that connects local businesses in south central Virginia with developers. He said there are currently about 100 members.

There being no one further wishing to speak, Chairman Gilliam closed the public hearing.

Chairman Gilliam stated he listened to several meetings on the topic of solar projects and with the recent ice storm, people were without power for 11 days. He asked if these could get the power back on faster.

Supervisor Jones said that due to bad weather, it would be an issue of transmission, not production.

Mr. Townsend said the project is designed with a screening and uses only a small portion of the parcel. He said the project meets all requirements. Some issues are transmission but some solar projects help with the stability of the system.

Supervisor Emert questioned the County Code section that was referenced previously. Mr. Love stated that is County Code definitions; he said in the *Code of Virginia* there is a Community Solar Program and that is what this site is being used for.

Supervisor Watson made a motion, seconded by Supervisor Townsend, to approve the Special Use Permit request by Elam Road Solar LLC for a proposed 3MWac community solar energy facility with conditions; the motion carried:

|      |                       |      |      |
|------|-----------------------|------|------|
| Aye: | Pattie Cooper-Jones   | Nay: | None |
|      | J. David Emert        |      |      |
|      | Llew W. Gilliam, Jr.  |      |      |
|      | Victor "Bill" Jenkins |      |      |
|      | E. Harrison Jones     |      |      |
|      | Odessa H. Pride       |      |      |
|      | Jerry R. Townsend     |      |      |
|      | Cannon Watson         |      |      |

**Elam Road Solar LLC  
PRINCE EDWARD COUNTY, VIRGINIA  
Special Use Permit Conditions**

**SECTION I. GENERAL PROVISIONS**

1. This Special Use Permit applies to the following properties for which a special use permit application was submitted:  
Tax Map Parcel Identification Number: 031-A-16  
The Special Use Permit application was submitted on 02/07/2023 by Elam Road Solar LLC on behalf of the owners of the said properties, and compliance with these conditions is the express duty of, and

these conditions shall bind, the Applicant and any assignee of the Applicant who operates the Solar Facility.

2. The Site shall be developed, constructed, operated, and decommissioned in compliance with all of the following:
  - a. All applicable federal, state, and local laws, statutes, ordinances, and regulations.
  - b. All written agreements entered into between the Applicant and the County, expressly including, but not limited to, a Solar Facility Siting Agreement.
  - c. The Site Plan approved by Prince Edward County.
  - d. The Decommissioning Plan approved by Prince Edward County.
  - e. The Emergency Response Plan approved by Prince Edward County.
  - f. The Construction Traffic Management Plan approved by Prince Edward County.
  - g. The Erosion and Sediment Control Plan approved by Prince Edward County.
  - h. The Stormwater Management Plan approved by Prince Edward County and/or DEQ.

Violation by the Applicant or by any one or more of Applicant's agents, employees, contractors, assigns, or successors in interest of any terms, conditions, or provisions of any of the foregoing shall constitute a violation of this Special Use Permit.

3. The following terms shall have the following meanings if or when used in these Conditions:
  - a. **"Abandoned"** means the discontinuation of power generation by the Solar Facility for a period of at least 180 consecutive days, except in the event of a force majeure event requiring reconstruction.
  - b. **"Applicant"** means Elam Road Solar LLC.
  - c. **"Approved Site Plan"** means the detailed drawing showing all equipment, excavation, landscaping, and other changes or improvements to be made to the real property or properties for the development of the Project following approval of the Special Use Permit Application by the Prince Edward County Planning Commission, and the Prince Edward County Board of Supervisors and administrative review and approval by Prince Edward County staff.
  - d. **"Board"** means the Board of Supervisors of Prince Edward County, Virginia.
  - e. **"Commercial Operation"** means the period beginning on the date that the sale of electricity generated from the Solar Facilities to a third party through the Grid commences pursuant to a Power Purchase Agreement and terminating contemporaneously with the commencement of Decommissioning.
  - f. **"County"** means Prince Edward County, Virginia.
  - g. **"County Administrator"** means the county administrator of Prince Edward County, Virginia.
  - h. **"Decommission" or "Decommissioning" or "Decommissioning Activities"** means the work on the Solar Facility to remove improvements on the real property and to otherwise comply with the Decommissioning Plan.
  - i. **"Decommissioning Commencement Date"** means the earliest date on which Decommissioning is required to begin under the terms set forth in these Special Use Permit Conditions.
  - j. **"Decommissioning Plan"** means the plan for Decommissioning Activities submitted by Elam Road Solar LLC and approved by the County.
  - k. **"Grid"** means the interconnected network for delivering electricity from producers to consumers (consisting of generating stations, electrical substations, high voltage transmission lines, and distribution lines that connect individual customers) to which the Project is connected and provides power.
  - l. **"Investor Owned Utility Company"** means an electric utility as defined in Section 56-576 of the Code of Virginia.
  - m. **"Operator"** means any party which undertakes the management, maintenance, and operation of the Solar Facility, including, but not limited to, as assignee of the Applicant.
  - n. **"Power Purchase Agreement"** means the written agreement pursuant to which electricity generated from the Solar Facilities is sold to a third party.

- o. **“Project”** means the Solar Facility on the parcel, including the following: (i) the development, design, procurement, construction, installation, commissioning, testing, interconnection, and start-up of the Solar Facility on the Site; (ii) the operation, repair, replacement, and maintenance of the Solar Facility on the Site; and (iii) the decommissioning and removal of the Solar Facility from the Site.
  - p. **“Related Entity”** or **“Related Entities”** means any two or more entities described in I.R.C. § 267(b).
  - q. **“Site”** or **“Solar Facility Site”** means all properties to be leased or purchased by the Applicant or any Related Entity for development in connection with the Project, identified as follows: Prince Edward County Tax Map Identification Number 031-A-16.
  - r. **“Site Plan”** means the detailed drawing showing all equipment, landscaping, roads, retention facilities, fencing, buffers, and other changes or improvements to be made to the real property or properties for the development of the Project.
  - s. **“Solar Facility”** or **“Solar Facilities”** means the Site together with all equipment, apparatus, or other items of personal property used for the construction, operation, or decommissioning of the Project.
  - t. **“Surety Review Date”** means the date by which the Applicant will update the cost estimate in the Decommissioning Plan every seven (7) years and reimburse the County for the actual and reasonable, out-of-pocket costs of each such independent review and analysis by a licensed engineer of each decommissioning cost estimate revision.
4. The Site shall be developed in general conformance with the information and exhibits submitted with the Special Use Permit application (the “SUP” Application), except as modified by associated conditions, the Approved Site Plan, and as required by the land development ordinances of Prince Edward County.
  5. This Special Use Permit (SUP) is issued to the owners of the properties for which the special use permit application was submitted (the Properties) and shall run with the land unless and until this SUP is revoked, expires, or is voided.
  6. An Approved Site Plan shall be required for this use.
  7. Prior to the issuance of construction permits, the Applicant shall record in the Circuit Court Clerk’s Office of Prince Edward County, Virginia a plat of survey delineating the property boundary and total acreage.
  8. The Applicant shall submit an Emergency Response Plan (the “ER Plan”) with the submission of the Site Plan. The ER Plan shall include fire suppression methods that can be deployed during both the construction and operation of the project. The ER Plan shall also include a program of education and training to be provided for County emergency response staff covering onsite emergency response.
  9. Unless approved in writing by the County, no signage shall be permitted on the Site; except that signage containing notices, warnings, or other information, if required by law or by applicable codes and standards, or deemed by the County to be in the interest of the safety and welfare of the community, shall be required.
  10. Elam Road Solar LLC will reimburse, or cause to be reimbursed, to the County all reasonable, out-of-pocket costs and fees incurred for professional services engaged for purposes of assisting the County during the application process and during construction, including, but not limited to, legal fees and consulting fees; however legal fees shall not be assessed to Elam Road Solar LLC after construction is completed. The purpose of the reimbursement payments is to defray the costs and expenses incurred by the County in connection with (i) the zoning and permitting processes related to the approval of the Solar Facility, (ii) the permitting process with federal and state agencies, as applicable, and (iii) the construction of the Solar Facility. Should the special use permit application submitted by Elam Road

Solar LLC for the Project not be approved by the County, no reimbursement under this paragraph will be owed by Elam Road Solar LLC to the County.

## **SECTION II. BUFFERS, HEIGHTS, AND SETBACKS**

11. Buffers throughout the Site shall include the following:
  - a. All setbacks shall be no less than those shown on the site plan approved by Prince Edward County.
  - b. The Site Plan will identify a maximum extent of Project area, outside of which solar panels or other equipment will not be located. The solar panels or other equipment of the Solar Facility will not be located within the standard setbacks established by Section 7-110 (D) of the County Ordinance.
  - c. The Site Plan will include a vegetative buffering plan (the “Vegetative Buffer Plan”) that will limit the visibility of the Solar Facility from the public rights-of-way adjacent to the Site. For purposes of this Condition, “Solar Facility” does not include the perimeter security fencing, gravel access road, or interconnection equipment. Also, the “Solar Facility” is not an objectionable feature, within the meaning of County Ordinance Section 7-110 (F). All vegetative buffering areas, as shown on the Vegetative Buffer Plan, shall enable insolation of the Solar Facility and may be both natural and planted, shall be a part of the approved Project, and should be protected from harvest so long as the Site is operated as a solar facility.
  - d. Vegetative buffering areas shall be installed (pursuant to the screening suggestions attached as Exhibit A) and, as necessary, managed to ensure health and preservation of the vegetation. Any vegetative buffering that is dead during the operating period shall be removed and replaced in conformance with the approved site plan, within a six (6) month time period during a typical growing period. The type and height of replacement vegetation shall be similar to that of which was originally planted during construction. In the event that the vegetative buffering is severely damaged due to an unusual weather occurrence or natural catastrophe, the Project shall have one year or one growing season, whichever is sooner, to replace or replant.
  - e. A 15’ screening buffer shall be observed with any bordering standing timber harvested after construction of the solar facility.
  - f. Electrical lines leaving the Solar Facility shall be underground until the point of reaching the first pole outside of the facility as to not impact the screening plan.
  - g. Any historical resources noted in the Virginia Department of Historic Resources Map must be identified, marked, and preserved at a setback of at least 100 feet, as reflected on the Site Plan.
  - h. The maximum height of ground mounted systems, equipment, and structures, as measured from the grade or base of the improvements to the highest point, shall not exceed eighteen (18) feet in height. Excluded from this height requirement are overhead electric distribution and transmission lines and poles, project substation, and utility switchyard.

## **SECTION III. CONSTRUCTION, TRAFFIC, and ROAD REPAIRS**

12. Subject to compliance with applicable site safety requirements and upon reasonable prior notice, the County Administrator, building official, zoning administrator, or environmental codes and compliance officer, or any party or parties designated by any one or more of those county officials, including other federal, state, or local government officials, shall be allowed to enter the Site at any time during construction. Once the facility has commenced Commercial Operation, subject to compliance with



applicable Site safety requirements, County officials may enter the Site upon at least one week's advance notice to the Solar Facility liaison.

13. All construction entrances for the Site shall be in general conformance with the information and exhibits submitted with this Special Use Permit application and must be authorized and approved by the Virginia Department of Transportation (VDOT).
14. All construction activity shall be conducted during daylight hours Monday-Saturday. Activities allowed on Sundays include only the following: onsite planning, walking and riding the Site by passenger vehicle (not heavy construction trucks or equipment), office work, and other activities that do not produce large quantities of traffic on the surrounding roads or loud construction noises within the Site. The Applicant shall comply with the Prince Edward County Noise Ordinance Chapter 46, Article II during operation but shall not be required to do so during construction.
15. All heavy construction traffic, including, but not limited to, dump trucks, tractors and trailers, supplier vehicles, and trucks hauling equipment shall enter the site at the designated private driveway along Route 639 (Elam Road).
16. The Applicant shall submit a Construction Traffic Management Plan ("CTMP") as part of the Site Plan. The CTMP shall address traffic control measures, an evaluation of the condition of the public roads along the Delivery Routes prior to construction, and a description and an estimate of any anticipated repairs to public roads that may arise due to damages attributable to construction of the Solar Facilities, which CTMP must be reviewed by a third-party selected by the County and paid by, and at the sole cost of, the Applicant.
17. Dust containment measures shall be utilized at all times, as necessary, to contain dust from constituting a nuisance to nearby residents.
18. No burning of stumps and/or debris will be allowed onsite at the subject solar facility.
19. The Solar Facilities shall be enclosed within chain link security fencing not less than six (6) feet in height.
20. The Project will not utilize permanent lighting. If installed at a later date, lighting will be downward facing, motion activated security lighting located at the Project entrance gate or at the control panels near the equipment pad.
21. Prior to commencement of construction, the Applicant shall provide the County a bond equal to 100% of the cost of the anticipated repairs to be made to the public road along the Delivery Routes, as defined in paragraph 22 below, including the entire public right of way along the Delivery Route. The bond may be in the form of a letter of credit, a surety bond, or a cash bond given to the County, to be held by the County without interest, but the form of any surety bond must be approved by the County Administrator. The County will release, return, and terminate the roadway surety upon completion of construction and Commercial Operation of the Project.
22. Delivery Routes to the site shall include Route 657 (Sulphur Spring Road), from its intersection with State Route 460 (Prince Edward Highway) and Route 639 (Elam Road) from Route 657 (Sulphur Spring Road) to the Elam Road Solar LLC site entrance.
23. The Solar Facilities shall be constructed and operational within two (2) years of approval. The Zoning Administrator may approve an extension of up to one (1) year upon written request from the Applicant detailing the need for an extension.
24. Solar panels will be constructed, maintained, and operated in accordance with national industry standards and regulations including the National Electrical Code, International Fire Code of the International Code Council and the National Fire Protection Association Fire Code, as provided in Va.

Code 15.2-2286. In the event of a conflict between the national industry standards and these Conditions, the national industry standards shall control so that as technology advances, updated technology may be used by the Applicant. Notwithstanding any of the foregoing, the use of any of the following materials at any time, whether in construction, maintenance, or operation of the facility, is expressly prohibited: cadmium telluride, cadmium, tellurium, GEN X, field-applied Teflon® coating, or any other materials prohibited by federal or state agencies.

25. Storage on the Site of power generated by the Facility or generated elsewhere is prohibited.
26. No panels, inverters, pyranometers, substations, or any other component of the Solar Facility, except fencing, shall be located in a floodplain.
27. Upon completion of the construction of the Solar Facilities, the Applicant shall submit a post-construction evaluation of the condition of the roads along the Delivery Routes to the County Administrator for approval. The post-construction evaluation shall include a plan for repairing any damage caused to the public roads along the Delivery Route directly attributable to the Applicant. The Applicant shall be responsible for causing such repairs to be completed to the satisfaction of the VDOT and shall be responsible for coordination of repairs with VDOT. All roadway repairs along the Delivery Routes shall be made at the sole expense of the Applicant.

#### **SECTION IV. ENVIRONMENTAL**

28. The Applicant shall submit a Stormwater Management Plan **and** an Erosion and Sediment Control Plan as part of the Site Plan. The Applicant shall reimburse, or cause to be reimbursed to, the County all reasonable, out-of-pocket costs incurred by the County related to retaining such third-party inspectors, plan reviewers, and advisors as reasonably necessary for project review and inspections. All such payments shall be remitted to the County within thirty (30) days of invoicing. The County shall retain the right to inspect the Site to verify the findings of the third-party inspectors upon reasonable, prior notice and subject to compliance with Site safety requirements. The phasing of land disturbance shall be detailed in the Erosion and Sediment Control plan and accompanying project narrative.
29. Stabilization of the Site shall be maintained at all times in compliance with Virginia Department of Environmental Quality (DEQ) standards, rules, requirements, and regulations. The Applicant and the Operator, or either one of them, shall notify the County within twenty-four (24) hours of receiving any DEQ notice of less than full compliance by the Project and shall, within forty-eight (48) hours of receipt, provide the County with a copy of the notice. Thereafter, the Applicant and the Operator, or either one of them, shall provide to the County within forty-eight (48) hours of transmission or receipt copies of all correspondence with DEQ regarding Project noncompliance issue until such time as the matter is fully resolved to the satisfaction of DEQ. In order to ensure orderly development of the Solar Facility and to protect the stabilization and environmental integrity and quality of the Site, no more than fifty percent (50%) of the total site development area shown on the Approved Site Plan may be disturbed at any point in time. For purposes of this condition number 29, an area for which any one or more of the following is true is not considered to be disturbed: the area has established ground cover, the County has determined that the area is not disturbed, an area where temporary stabilization measures have been implemented, gravel driveways, or laydown areas.
30. Soil testing shall be conducted on the Site as follows:
  - a. Testing shall be conducted in no less than three (3) locations on the Site, at least one location being within proximity to panels of each different type or manufacturer. Samples will be collected from a depth of six inches below ground surface.
  - b. Testing shall be conducted prior to the issuance of a land disturbance permit and every five years thereafter. Testing also shall be conducted immediately prior to Decommissioning and immediately following the termination of Decommissioning.

- c. Samples shall be analyzed for Priority Pollutant 13 Metals (arsenic, antimony, beryllium, cadmium, chromium, copper, lead, mercury, nickel, selenium, silver, thallium, and zinc) in accordance with EPA methods SW 6020, SW 6020A, SW1312, and 200.8.
- d. Testing shall be performed by a service provider retained by the Operator but approved by the County.
- e. A test report for each testing event, including an executive summary, shall be provided to the Prince Edward County zoning administrator within ten (10) days of the completion of such report.
- f. No costs shall be incurred by Prince Edward County for soil testing or reports of soil testing provided to Prince Edward County.

**SECTION V. DECOMMISSIONING**

- 31. Decommissioning shall be conducted in accordance with the Decommissioning Plan approved by Prince Edward County.
- 32. The Applicant or the Operator shall provide a Notice of Decommission to the County Administrator of Prince Edward County within thirty days of a determination to cease Operation of the Solar Facility.
- 33. Prior to the commencement of construction, the Applicant shall submit to the County and receive County approval of a Decommissioning Plan. The Applicant shall comply with all terms and conditions of the Decommissioning Plan as approved by the County. The Decommissioning Plan at a minimum shall include provisions regarding the following:
  - a. Specifications for the removal of all solar equipment, buildings, cabling, electrical components, foundations, pilings, and fencing.
  - b. A requirement that all Site real property must be restored to the condition of the property as of the date Construction commences (reasonable wear and tear excepted).
  - c. A requirement that the property must be stabilized so as to adequately control, prevent, and minimize any and all erosion or sediment runoff, consistent with the approved Erosion and Sediment Control Plan.
- 34. Decommissioning shall begin immediately after the Facility has, for a period of six (6) consecutive months, ceased operating as a solar energy facility distributing energy to the electrical grid and shall be diligently pursued, as determined by the County in its sole discretion, and completed within eighteen (18) months from the Decommissioning Commencement Date. Prior to its expiration, the County may extend this Decommissioning period by six (6) months if the County finds that the Operator commenced Decommissioning the Solar Facility diligently and continuously worked to Decommission the Facility throughout the Decommissioning period, and is reasonably expected to complete the Decommissioning within the additional six month period.
- 35. Periods during which the Facility is not operational for maintenance, repair, or due to a catastrophic event beyond the control of Elam Road Solar LLC during which time Elam Road Solar LLC works diligently to return the Facility to full Commercial Operation, shall not constitute the cessation of operations requiring the initiation of Decommissioning requirements herein. Elam Road Solar LLC must provide written notice and evidence of the Solar Facility status and repair efforts to the County Administrator during the period in which the Solar Facility is not fully operational. Such notice shall identify the last day on which the Facility was fully operational. Regardless of the efforts of Elam Road Solar LLC to return the Solar Facility to full Commercial Operation, if the Solar Facility does not operate as a solar energy facility distributing energy to the electrical grid after the catastrophic event for a period of eighteen (18) months, the Project shall be deemed Abandoned and Elam Road Solar LLC shall commence Decommissioning no later than the 548th day after the catastrophic event.

36. Any change of party responsible for Decommissioning of the facility, or change in any part of the contact information, shall be reported to the County Administrator within sixty (60) days of the change(s).
37. If Decommissioning Activities are not completed within the allotted time, or if the Project is Abandoned, the County may complete or have completed at its expense the Decommissioning Activities required under the terms of the Decommissioning Plan and may recover all costs of completing those Decommissioning Activities from the surety provided as set forth herein.
38. To secure the costs of Decommissioning, Elam Road Solar LLC or its successor shall at all times, beginning at commencement of construction and until the termination of Decommissioning, provide financial surety in a form and in an amount approved by the County. If the Solar Facility is transferred to a public utility or an Investor or Member Owned Utility Company (e.g.,: Dominion Energy, Old Dominion Electric Cooperative or its successor entity), the surety required of the Applicant may be cancelled at the time of the transfer and no further surety will be required.
39. The amount of the surety required shall be 100% of the estimated Decommissioning costs estimated at each Surety Review Date, less the scrap or repurposing value of the Solar Facility. The estimated costs and surety to meet the above requirements shall be reviewed by the County Administrator on each Surety Review Date, at which time the County Administrator shall determine if the estimates adequately reflect the Decommissioning costs and any scrap or repurposing value and that the surety will guarantee performance. Should the County Administrator determine that estimated costs and surety are insufficient, the County Administrator and Elam Road Solar LLC shall mutually agree to determine the correct surety amount; and Elam Road Solar LLC shall then provide the agreed, adequate surety within one hundred eighty (180) days following the Surety Review Date or, if later, within thirty (30) days after the County Administrator and Elam Road Solar LLC agree on the adequate surety amount.
40. Surety must be provided in the form of a cash bond deposited with the County; by an irrevocable letter of credit provided for the County's benefit; or by a surety bond listing the County as the obligee, an hypothecated account, an escrow account, or a guaranty issued by a credit-worthy entity, or as otherwise provided in Section 15.2-2241.2 of the Code of Virginia.
  - a. A cash bond shall be in the form of a cashier's check or certified check deposited with the County which has cleared all issuing institutions. Any interest accruing on such funds shall be added to the total amount and retained by the County for Decommissioning. The deposit shall be accompanied by a letter agreement, acceptable to, and issued by, the County Administrator, confirming that the cash deposit is to be held by the County to guarantee the performance of the Decommissioning work required herein, and should the Solar Facility be Abandoned or should the Decommissioning work not be diligently undertaken or performed according to the requirements herein, or should the Special Use Permit be revoked, lapse, expire, or be voided due to violation thereof, the County may expend the deposited funds to undertake the Decommissioning work required herein, without more, after providing written notice to the person identified as owner of the property in the land records of Prince Edward County as of the date of the notice. Within six (6) months of the completion of the Decommissioning work required herein by a person or entity other than the County or a contractor engaged by the County, as confirmed by the County Administrator, the cash bond and accrued interest, less any amounts expended by the County as allowed herein, shall be released and paid to Elam Road Solar LLC or, if the Project has been Abandoned, to the person identified as owner of the property in land records of Prince Edward County as of the date of the completed Decommissioning or as otherwise directed by that owner of the property.
  - b. An irrevocable letter of credit shall mean an instrument provided by a lending institution guaranteeing payment to the County within seventy-two (72) hours of the County's written notice to the institution that the Solar Facility has been Abandoned or the Decommissioning

Activities have not been diligently undertaken or performed according to the requirements herein and demand to the institution for the funds, without more. The letter of credit shall have no expiration date or required renewal and shall remain in effect for the benefit of the County and shall under no circumstances be withdrawn before the Decommissioning Activities required herein are completed or the amount guaranteed has been fully drawn by the County. The letter of credit shall require that the County be notified thirty (30) days prior to any cancellation or alteration of the letter of credit. Should the County receive notice that the letter of credit will be cancelled or otherwise become unavailable or decrease, or should this Special Use Permit be revoked, lapse, expire or be voided due to violation thereof by Elam Road Solar LLC, the County may, immediately draw down the entirety of the letter of credit and convert the surety to a cash bond to be deposited with the County and subject to the terms herein; this shall be specifically reflected in the language of the irrevocable letter of credit. The County may expend the guaranteed funds, without more, to undertake the Decommissioning Activities required herein and required pursuant to the terms of the Decommissioning Plan after providing written notice to Elam Road Solar LLC or, if the Project is Abandoned, to the person identified as the owner of the Property in the land records of Prince Edward County as of the date of the notice. Within six (6) months following the completion of the Decommissioning Activities required herein and required pursuant to the terms of the Decommissioning Plan by a person or entity other than the County or a contractor engaged by the County, as confirmed by the County Administrator, the letter of credit shall be released by the County and any amounts drawn on the letter of credit, less any amounts expended by the County as allowed herein, shall be released and paid to Elam Road Solar LLC or, if the Project has been Abandoned, to the person identified as owner of the property in land records of Prince Edward County as of the date of the completed Decommissioning or as otherwise directed by that owner of the property.

- c. A surety bond shall mean a bond issued by a company with an AM Best rating of A++, that is treasury listed, and that is licensed to do business in the Commonwealth of Virginia. The surety bond shall list the County as an obligee and shall remain in effect for the benefit of the County and shall under no circumstances be withdrawn or cancelled before the Decommissioning Activities required herein and required by the terms of the Decommissioning Plan are completed or the amount guaranteed has been fully paid to the County. The surety bond shall require that the County be notified thirty (30) days prior to any cancellation or alteration of the bond. Should the County receive notice that the surety bond will be cancelled or otherwise become unavailable or decrease below the limits required herein, or should the Special Use Permit be revoked, lapse, expire or be voided due to violation thereof by Elam Road Solar LLC, the County may, immediately file a claim, for the entirety of the amount of the bond, the guarantor shall pay the amounts guaranteed and the County shall convert the surety to a cash bond to be deposited with the County and subject to the terms herein; this shall be specifically reflected in the language of the surety bond. The County may expend the guaranteed funds, without more, to undertake the Decommissioning Activities required herein and required pursuant to the terms of the Decommissioning Plan, after providing written notice to Elam Road Solar LLC, or, if the Project is Abandoned, to the person identified as the owner of the Property in the land records of Prince Edward County as of the date of the notice. Within six (6) months following the completion of the Decommissioning Activities required herein by a person or entity other than the County or a contractor engaged by the County, as confirmed by the County Administrator, the surety bond shall be released by the County, and the bond funds paid to the County less any amounts expended by the County as allowed herein, shall be released and paid to Elam Road Solar LLC or, if the Project has been Abandoned, to the person identified as owner of the property in land records of Prince Edward County as of the date of the completed Decommissioning or as otherwise directed by that owner of the property.

41. Should this Special Use Permit be revoked, lapse, expire, or be voided due to violation thereof, the County may immediately draw down all of the surety funds and convert them into a cash bond for purposes of Decommissioning as set forth hereunder and as set forth in the Decommissioning Plan. In

such case, no contractual agreement shall be required for the cash bond. This shall be reflected in the surety provided.

42. Should the funds guaranteed for the Decommissioning Activities for any reason not be sufficient for the County to complete the Decommissioning Activities as allowed for herein and as set forth in the Decommissioning Plan, Elam Road Solar LLC or its successor, shall be and shall remain liable to the County for the difference between the guaranteed funds and the amounts required to Decommission the Solar Facility and shall pay the difference to the County upon demand. The County shall not be liable to any party in any way for the funds drawn pursuant to the conditions set out herein and expended in relation to Decommissioning.
43. Should the Facility be Abandoned, or should the Special Use Permit be revoked, lapse, expire, or be voided due to violation thereof, or should the Decommissioning Activities not be diligently undertaken or performed, and should the County draw down the funds for the purpose of performing the Decommissioning Activities and mobilize its contractors to perform the Decommissioning Activities or otherwise incur liability to its contractors for the performance of the Decommissioning Activities, Elam Road Solar LLC, its successor or agent, shall have no right to perform the Decommissioning Activities unless specifically authorized by the County in a writing that confirms that the County has incurred no liability to any contractors to perform the Activities or that any such liability is transferrable as deemed acceptable to the County. The Applicant or the Operator shall immediately, upon written demand by the County or any person or entity authorized to act on behalf of the County, without more, grant or release to the County, or any person or entity authorized to act on behalf of the County, under terms deemed acceptable by the County, all necessary real property rights, personal property rights, either or both, as determined solely by the County, other than fee simple ownership or a leasehold interest of the real property, so that the County or any person or entity authorized to act on behalf of the County may undertake any required Decommissioning Activities that have not otherwise been performed as required. This shall include, but may not be limited to, releasing any interest in the personal property, facilities, fixtures, and structures which are to be removed and recycled, disposed of, or otherwise demolished.

In Re: Public Hearing – Solar Siting Agreement, Elam Road Solar, LLC

Chairman Gilliam announced that this was the date and time scheduled for a public hearing to receive citizen input, pursuant to § 15.2-2316.8(B) of the *Code of Virginia*, a consideration of a siting agreement by Elam Road Solar, LLC, to construct and operate a 3 MWac community solar energy facility on Tax Map Parcel 031-A-15, on Elam Road, Pamplin, Virginia. Notice of this hearing was advertised according to law in the Wednesday, March 29, 2023, and Wednesday, April 5, 2023 editions of THE FARMVILLE HERALD, a newspaper published in the County of Prince Edward.

Mr. Love stated the County has been in negotiations with Sun Tribe Development dba Elam Road Solar, LLC, for a siting agreement related to construction and operation of a 3MWac solar energy facility on a 33-acre portion of Tax Map Parcel 031-A-16, containing a total of 136+/- acres, which is zoned A-1, Agricultural Conservation, on Elam Road, Prospect, VA.

Pursuant to §15.2-2316.S(B) of the Code of Virginia, the host locality shall schedule a public hearing, pursuant to Subsection A of § 15.2-2204, for the purpose of consideration of such siting agreement. If a majority of a quorum of the members of the governing body present at such public hearing approve of such siting agreement, the siting agreement shall be executed by the signatures of (i) the chief executive officer of the host locality and (ii) the applicant or the applicant's authorized agent. The siting agreement shall continue in effect until it is amended, revoked, or suspended.

The siting agreement includes a one-time upfront voluntary payment of \$30,000 (\$10,000 per MWac) plus an annual payment of \$1,400 per MWac.

Chairman Gilliam opened the public hearing.

Nate Boehmer asked how many projects have been set where the property owner lives near the location.

Mr. Townsend said there are several currently and several more in development where the property owners live on the site. He said there is screening with 15 feet of trees and vegetative buffers.

Mr. Stanley said there is a project in Middlesex County that the solar field is adjacent to and provides electricity for the school system.

Chairman Gilliam stated he knows of a dairy farm that uses five acres of solar panels which provide power to the whole dairy farm and the owner sells the excess back to the power company. Discussion followed.

There being no one further wishing to speak, Chairman Gilliam closed the public hearing.

Supervisor Emert made a motion, seconded by Supervisor Townsend, to approve the Siting Agreement with Elam Road Solar LLC for a proposed 3MWac solar energy facility; the motion carried:

|      |                       |           |
|------|-----------------------|-----------|
| Aye: | Pattie Cooper-Jones   | Nay: None |
|      | J. David Emert        |           |
|      | Llew W. Gilliam, Jr.  |           |
|      | Victor "Bill" Jenkins |           |
|      | E. Harrison Jones     |           |
|      | Odessa H. Pride       |           |
|      | Jerry R. Townsend     |           |
|      | Cannon Watson         |           |

### SOLAR FACILITY SITING AGREEMENT

This Solar Facility Siting Agreement (the "**Agreement**"), dated as of April 11, 2023 (the "**Effective Date**"), is made by and between Prince Edward County, Virginia, a political subdivision of the Commonwealth of Virginia (the "**County**"), and Elam Road Solar LLC, a Virginia limited liability company (the "**Applicant**"). The County and the Applicant are referred to herein each as a "**Party**" and collectively, the "**Parties**".

## RECITALS

WHEREAS, the Applicant intends to build, operate, and decommission a commercial solar photovoltaic (electric energy) generation facility and associated electric grid interconnection facilities (**collectively, the “Project”**) on certain real property in the County identified as Tax Map Parcel Number 031-A-16 (the **“Property”**);

WHEREAS, the Project will be three (3) megawatts or less and therefore is not subject to (i) the requirements of Virginia Code § 15.2-2316.7 including, without limitation, the obligation of the Applicant to meet, discuss and negotiate a siting agreement with the County, or (ii) the revenue share ordinance adopted by the County pursuant to Virginia Code § 58.1-2636;

WHEREAS, notwithstanding the foregoing, the County issued a Special Use Permit (“SUP Number”) for the Project dated April 11, 2023 Year (the **“SUP”**), which SUP requires, among other things, that the Project be developed, constructed, operated and decommissioned in compliance with a solar facility siting agreement between the Applicant and the County;

WHEREAS, in furtherance of the satisfaction of the conditions set forth in the SUP, the Parties desire to enter into this Agreement to provide certain financial compensation to the County as authorized by Virginia Code § 15.2-2288.8(B) and pursuant to the terms and conditions hereof;

WHEREAS, the Applicant has agreed to the payments and financial terms contained herein; and

WHEREAS, pursuant to the requirement of Virginia Code § 15.2-2316.8(B), the County held a public hearing in accordance with subdivision A of Virginia Code § 15.2-2204 for the purpose of considering this Agreement, after which a majority of a quorum of the members of the Prince Edward County Board of Supervisors approved this Agreement.

## AGREEMENT

NOW, THEREFORE, the County and the Applicant, intending to be legally bound hereby and in consideration of the mutual covenants contained herein, the receipt and sufficiency of which are hereby acknowledged, do hereby agree as follows:

### Article I

#### Conditions

1. **SUP Conditions.** The Applicant acknowledges and agrees that it is bound by all the terms and conditions contained in the SUP. The SUP is attached hereto as **Exhibit B** and is hereby incorporated herein. Violation by the Applicant or by any of the Applicant’s agents, assigns, or successors in interest of any terms and conditions of the SUP or of any other applicable zoning requirements of the County shall constitute an event of default under Section 13 of this Agreement.

### Article II

#### Payments

1. **Purpose.** The Parties acknowledge that the payments required hereunder shall be made to the County for use in funding substantial public improvements, the need for which is not generated solely by the granting of the SUP, and that such payments are reasonably related to the Project; in recognition thereof, the Applicant agrees



to make the payments set forth on Exhibit A (in accordance with paragraph 2 of this Article), as permitted under Virginia Code § 15.2-2288.8(B).

**2. Payment Structure.** The Applicant shall make payments to the County, as follows:

a. A one-time payment to the County in the amount of \$30,000.00, payable within six (6) months of the Commercial Operation Date (as defined below) (the “Initial Payment”).

b. Annual payments as set forth in Exhibit A attached hereto and incorporated herein (each, an “Annual Payment”, and collectively, the “Annual Payments”, and together with the Initial Payment, the “Payments”). **The Annual Payments shall begin no later than six (6) months** following the Commercial Operation Date on a prorated basis for that year.<sup>1</sup> As used herein, “Commercial Operation Date” means the date on which the Project commences “Commercial Operation,” which means the point at which the Project becomes fully operational and can begin selling power under the terms of a power purchase or offtake agreement. Generation of test energy shall not be deemed Commercial Operation. The Annual Payments shall be due and payable on or before December 1st of each year following the Commercial Operation Date until the completion of the decommissioning of the Project by the Applicant (the “Termination Date”), as evidenced by written notice to the County from the Applicant that decommissioning of the Project is complete. The Parties acknowledge that, except as otherwise provided herein, the Applicant’s obligation to make the Annual Payments shall be conditioned upon the Project commencing Commercial Operation. Each Annual Payment shall be made to the County in one lump sum payment made annually during the term of this Agreement. Notwithstanding Section 70-242(a) of the Code of the County of Prince Edward, Virginia, and pursuant to Virginia Code § 58.1-2606.1(B), the Annual Payments shall constitute the assessment of a revenue share on the Project by the County.

**3. Structure of the Payments; Statement of Benefit.** The Applicant agrees that, by entering into this Agreement, it is bound by law to make the Payments in accordance with this Agreement. The Parties acknowledge and agree that this Agreement is fair and mutually beneficial to them both and that this Agreement provides for a clear and predictable stream of future payments to the County in amounts fair to both Parties.

### Article III

#### **Miscellaneous Terms**

**1. Term; Termination; Automatic Renewal.** This Agreement shall commence on the Effective Date and shall continue until the **Termination Date**. **The Applicant shall have no obligation to make any Payments after the Project is decommissioned. The Annual Payment** due for the year in which the Project is decommissioned shall be prorated as of the Termination Date. Written notice of termination shall be given by Applicant (a “Notice of Termination”), and such Notice of Termination shall provide an anticipated termination date that is at least three (3) months from the date the Notice of Termination is given. The termination of this Agreement shall not limit the Applicant’s legal obligation to pay local taxes in accordance with applicable law at such time and for such period as the Project remains in operation. Notwithstanding anything contained herein to the contrary, the Applicant may, in its sole discretion, terminate this Agreement at any time prior to Commercial Operation by delivery of written notice thereof to the County.

**2. Mutual Covenants.** The Applicant covenants to the County that it will pay the County the amounts

---

<sup>1</sup> If the Commercial Operation Date is June 1 or later, that first year’s prorated payment shall be due and payable on or before December 1 of that first year.

due hereunder when due in accordance with the terms of this Agreement, and will not seek to invalidate this Agreement, or otherwise take a position adverse to the purpose or validity of this Agreement. The County covenants to the Applicant that it will not seek to invalidate this Agreement or otherwise take a position adverse to the purpose or validity of this Agreement.

**3. No Obligation to Develop.** The Applicant has no obligation to develop or construct the Project, and this Agreement does not require any Payments until after the Commercial Operation Date. Any test energy or other energy produced prior to the Commercial Operation Date shall not trigger any Payments under this Agreement. It is understood that development of the Project by the Applicant is contingent upon several factors including, but not limited to, regulatory approvals, availability and cost of equipment and financing, and market demand for the Project's energy. No election by the Applicant to terminate, defer, suspend, or modify plans to develop the Project shall be deemed a default of the Applicant under this Agreement.

**4. Successors and Assigns.** This Agreement shall be binding upon the successors or assigns of the Applicant, and the obligations created hereunder shall be covenants running with the Property. If Applicant sells, transfers, leases, or assigns all or substantially all of its interests in the Project or the ownership of the Applicant, this Agreement will automatically be assumed by and be binding on the purchaser or transferee. Upon such assumption, the sale, transfer, lease, or assignment shall relieve the Applicant of all obligations and liabilities under this Agreement accruing from and after the date of sale or transfer, and the purchaser or transferee shall automatically become responsible under this Agreement. The Applicant shall execute such documentation as reasonably requested by the County to memorialize the assignment and assumption by the purchaser or transferee.

**5. Execution of Agreement Deems Project "Substantially In Accord" with County's Comprehensive Plan.** The County acknowledges the Planning Commission's determination made on or about March 21, 2023 finding the Project in substantial accord with the County's Comprehensive Plan and hereby accepts, ratifies, and approves of such determination for the reasons stated by the Planning Commission. The County's execution of this Agreement affirms that the Project is substantially in accord with the County's Comprehensive Plan in satisfaction of the requirements of Virginia Code § 15.2-2232.

**6. Memorandum of Agreement.** A memorandum of this Agreement, in a form substantially similar to that attached as Exhibit C hereto (the "Memorandum"), shall be recorded in the land records of the Clerk's Office of the Circuit Court of the County (the "Clerk's Office"). Such recordation shall be at the Applicant's sole cost and expense and shall occur as soon as reasonably practicable after the Effective Date. Upon the termination of this Agreement, the Parties shall execute and record a release of the Memorandum in the Clerk's Office.

**7. Notices.** Except as otherwise provided herein, all notices required to be given or authorized to be given pursuant to this Agreement shall be in writing and shall be delivered or sent by registered or certified mail, postage prepaid, by recognized overnight courier, or by commercial messenger to:

If to the County:

Prince Edward County, Virginia  
111 South Street, Third Floor  
PO Box 382  
Farmville, Virginia 23901  
Attn: Douglas P. Stanley, County Administrator

If to the Applicant:

Elam Road Solar LLC  
107 5<sup>th</sup> Street Southeast  
Charlottesville, VA, 22902

The County and the Applicant, by notice given hereunder, may designate any further or different persons or addresses to which subsequent notices shall be sent.

**8. Governing Law; Jurisdiction; Venue.** THIS AGREEMENT SHALL BE GOVERNED BY AND CONSTRUED IN ACCORDANCE WITH THE LAWS OF THE COMMONWEALTH OF VIRGINIA, WITHOUT REGARD TO ANY OF ITS PRINCIPLES OF CONFLICTS OF LAWS OR OTHER LAWS WHICH WOULD RESULT IN THE APPLICATION OF THE LAWS OF ANOTHER JURISDICTION. THE PARTIES HERETO (A) AGREE THAT ANY SUIT, ACTION OR OTHER LEGAL PROCEEDING, AS BETWEEN THE PARTIES HERETO, ARISING OUT OF OR RELATING TO THIS AGREEMENT SHALL BE BROUGHT AND TRIED ONLY IN THE CIRCUIT COURT OF PRINCE EDWARD COUNTY, VIRGINIA, (B) CONSENT TO THE JURISDICTION OF SUCH COURT IN ANY SUCH SUIT, ACTION OR PROCEEDING, AND (C) WAIVE ANY OBJECTION WHICH ANY OF THEM MAY HAVE TO THE LAYING OF VENUE OR ANY SUCH SUIT, ACTION, OR PROCEEDING IN SUCH COURT AND ANY CLAIM THAT ANY SUCH SUIT, ACTION, OR PROCEEDING HAS BEEN BROUGHT IN AN INCONVENIENT FORUM. THE PARTIES HERETO AGREE THAT A FINAL JUDGMENT IN ANY SUCH SUIT, ACTION, OR PROCEEDING SHALL BE CONCLUSIVE AND MAY BE ENFORCED IN OTHER JURISDICTIONS BY SUIT ON THE JUDGMENT OR IN ANY OTHER MANNER PROVIDED BY LAW.

**9. Confidentiality.** This Agreement, once placed on the docket for consideration by the Prince Edward County Board of Supervisors, is a public document, subject to production under the Virginia Freedom of Information Act (“FOIA”). The County understands and acknowledges that the Applicant, and as applicable, its associates, contractors, partners and affiliates, utilize confidential and proprietary “state-of-the-art” information and data in their operations (“Confidential Information”), and that disclosure of any such information, including, but not limited to, disclosures of technical, financial or other information concerning the Applicant or any affiliated entity could result in substantial harm to them and could thereby have a significant detrimental impact on their employees and also upon the County. The County acknowledges that during the development and negotiation of this Agreement, certain Confidential Information may be, or may have been, shared with the County by the Applicant. The Applicant agrees to clearly identify any information it deems to be Confidential Information and not subject to mandatory disclosure under FOIA or other applicable law as Confidential Information at the time it provides such information to the County. The County agrees that, except as required by law and pursuant to the County’s police powers, neither the County nor any employee, agent, or contractor of the County will (i) knowingly or intentionally disclose or otherwise divulge any such Confidential Information to any person, firm, governmental body or agency, or any other entity unless a request for such Confidential Information is made and granted under an applicable provision of local, state or federal law. Upon receipt of such a request but before transmitting any documents or information which may contain Confidential Information to the requestor, the County shall contact Applicant to review the request for information and associated documents to determine if any Confidential Information is at risk of disclosure. If Confidential Information exists, the Applicant may intervene on behalf of the County and defend against disclosure of the Confidential Information. The County agrees to cooperate in this defense and to the extent allowed by law, work to protect the Confidential Information of the Applicant.

**10. Insurance.** Upon commencement of construction of the Project and throughout Commercial Operation, the Applicant will obtain and maintain in force the following policies of insurance covering the Project facilities and the Applicant’s activities on the Property: comprehensive general liability insurance with minimum coverage of at least \$500,000 for property damage, \$1,000,000 for bodily injury or death to any one person, and a minimum combined occurrence and annual coverage of \$2,000,000.

11. **Modification.** This Agreement may be modified only in writing duly executed by the Parties hereto.

12. **Assignment.** This Agreement may be assigned by the Applicant to any party without the prior consent of the County, so long as such assignment is expressly made subject to all terms and conditions of this Agreement, and provided that such assignment shall not be effective against the County until such time as the Applicant delivers written notice of such assignment.

13. **Default.**

A. In the event of a default under this Agreement, the non-defaulting Party shall give written notice to the defaulting Party, describing the alleged default in reasonably sufficient detail. If a Party has not cured, as described by this Agreement, its default within thirty (30) days after receiving written notice of the default from the non-defaulting Party, or if the default cannot be cured within thirty (30) days thereof and the defaulting Party has not begun and pursued with diligence to cure said default within such thirty (30) day period, the non-defaulting Party shall have the right, but not the obligation, to cure such default and to charge the defaulting Party for the cost of curing such default, including the right to offset said costs of curing the default against any sums due or which become due to the defaulting Party under this Agreement. Such non-defaulting Party shall, in its reasonable judgment, attempt to use the most economically reasonable method of curing any such default.

B. This Agreement may be terminated by the County in the event of a material breach of this Agreement that has not been cured within sixty (60) days after written notice thereof. If a cure is initiated within such period, the Agreement shall not terminate. A material breach shall mean a failure to comply with (1) any of the provisions of this Agreement relating to the Payments, (2) the permits and approvals under which the Project will be operated or built, which failure results in a loss of such permits and approvals such that the Project is prohibited from operating, or (3) applicable federal or state laws, approvals, or regulations. A material breach shall also include the insolvency of the Applicant or its assignee, such insolvency to be established by the filing of a voluntary petition in bankruptcy that is not dismissed within one hundred eighty (180) days of its filing. A material breach shall also include a violation of the Special Use Permit issued to the Applicant, attached hereto as Exhibit B. Provided, however, the Applicant complying or taking action consistent with any governmental or regulatory warning letter, notice of violation, or plan of action shall be deemed a cure if the compliance or the action is initiated within sixty (60) days of the Applicant receiving the warning letter, notice of violation, or action plan. In the event the Applicant receives notice of a material breach that state or federal authorities determine threatens the safety of the public or threatens to cause material environmental damage and fails to resolve such material breach as soon as is reasonably practicable, the County shall be entitled to terminate this Agreement. If a dispute exists as to whether an amount is owed or a breach of this Agreement has occurred, either Party may seek a declaratory judgment or other appropriate action in the Prince Edward County Circuit Court. If the dispute involves an amount owed to the County, the Applicant shall submit said disputed amount to the Clerk's Office to be held pending resolution of the dispute. The cure period and any termination of this Agreement shall be extended and tolled pending a decision by the Prince Edward County Circuit Court on the declaratory judgment or other action filed.

C. If either the County or the Applicant files a lawsuit, counterclaim, or crossclaim to enforce any provision of this Agreement or to seek a declaratory judgment, the prevailing Party is entitled to all reasonable attorneys' fees, litigation expenses, and court costs.

14. **Severability; Invalidity Clause.** Any provision of this Agreement that conflicts with applicable law or is held to be void or unenforceable shall be ineffective to the extent of such conflict, voidness, or unenforceability without invalidating the remaining provisions hereof, which remaining provisions shall be enforceable to the fullest extent permitted under applicable law. If, for any reason, including a change in applicable law, it is ever determined by any court or governmental authority of competent jurisdiction that this Agreement is invalid, then the Parties shall, subject to any necessary County meeting vote or procedures, undertake reasonable efforts to amend and or reauthorize this Agreement so as to render the invalid provisions herein lawful, valid, and

enforceable. If the Parties are unable to do so, this Agreement shall terminate as of the date of such determination of invalidity, and the Property and Project will thereafter be assessed and taxed as though this Agreement did not exist. The Parties will cooperate with each other and use reasonable efforts to defend against and contest any challenge to this Agreement by a third party.

**15. Entire Agreement.** This Agreement and any exhibits or other attachments constitute the entire agreement and supersedes all other prior agreements and understandings, both written and oral, between the Parties hereto with respect to the subject matter hereof. No provision of this Agreement can be modified, altered, or amended except in a writing executed by all Parties hereto.

**16. Construction.** This Agreement was drafted with input by the County and the Applicant, and no presumption shall exist against any Party.

**17. Force Majeure.**

A. "Force Majeure Event" means the occurrence of:

(i) an act of war (whether declared or not), hostilities, invasion, act of foreign enemies, terrorism or civil disorder;

(ii) a strike or strikes or other industrial action or blockade or embargo or any other form of civil disturbance (whether lawful or not), in each case affecting on a general basis the industry related to the construction, operation, or maintenance of the Project, as for example but not in limitation, the interruption in the supply of replacement solar panels, and which is not attributable to any unreasonable action or inaction on the part of Applicant or any of its subcontractors or suppliers and the settlement of which is beyond the reasonable control of all such persons;

(iii) specific incidents of exceptional adverse weather conditions in excess of those required to be designed for;

(iv) tempest, earthquake, or any other natural disaster of overwhelming proportions and the disruption of operations resulting therefrom;

(v) discontinuation of electricity supply, or unanticipated termination of a power purchase agreement;

(vi) other unforeseeable circumstances beyond the control of the Parties against which it would have been unreasonable for the affected Party to take precautions and which the affected Party cannot avoid even by using its best efforts, including quarantines ordered by competent governmental authority in the event of a public health emergency, which in each case directly causes either party to be unable to comply with all or a material part of its obligations under this Agreement.

B. Neither Party will be in breach of its obligations under this Agreement or incur any liability to the other Party for any losses or damages of any nature whatsoever incurred or suffered by that other (otherwise than under any express indemnity in this Agreement) if and to the extent it is prevented from carrying out those obligations by, or such losses or damages are caused by, a Force Majeure Event except to the extent that the relevant breach of its obligations would have occurred, or the relevant losses or damages would have arisen, even if the Force Majeure Event had not occurred.

C. As soon as reasonably practicable after the start of a Force Majeure Event, and within a reasonable time after the end of a Force Majeure Event, any Party invoking it will submit to the other Party reasonable proof of the nature of the Force Majeure Event and of its effect upon the performance of the Party's obligations under this Agreement.

D. Applicant will, and will ensure that its contractors will, at all times take all reasonable steps within their respective powers and consistent with good operating practices (but without incurring unreasonable additional costs) to:

- (i) prevent Force Majeure Events affecting the performance of Applicant's obligations under this Agreement;
- (ii) mitigate the effect of any Force Majeure Event; and
- (iii) comply with its obligations under this Agreement.

E. The Parties will consult together in relation to the above matters following the occurrence of a Force Majeure Event.

F. Should a single Force Majeure Event occur for a continuous period of more than one hundred eighty (180) days, then the Parties shall endeavor to agree on any modifications to this Agreement (including without limitation, determination of new revenue sharing payments) that are equitable, having due regard to the nature of the ability of Applicant to continue to meet its financial obligations to the County.

G. For the avoidance of doubt, a Force Majeure Event shall not include (a) financial distress or the inability of either Party to make a profit or avoid a financial loss, (b) changes in market prices or conditions, or (c) a Party's financial inability to perform its obligations hereunder, except such occurrences (a)-(c) that arise from a Force Majeure Event.

**18. Third Party Beneficiaries.** This Agreement is solely for the benefit of the Parties hereto and their respective successors and permitted assigns, and no other person shall have any right, benefit, priority, or interest in, under, or because of the existence of, this Agreement.

**19. Counterparts; Electronic Signatures.** This Agreement may be executed simultaneously in any number of counterparts, each of which shall be deemed to be an original, and all of which shall constitute one and the same instrument. A signed copy of this Agreement delivered by e-mail/PDF or other means of electronic transmission shall be deemed to have the same legal effect as delivery of an original signed copy of this Agreement.

*[signature page follows]*

**IN WITNESS WHEREOF**, the Parties hereto have caused this Agreement to be executed by the authorized representatives whose names and titles appear below as of the Effective Date.

**Elam Road Solar LLC, a Virginia limited liability company**

**By:** \_\_\_\_\_

**Name:** \_\_\_\_\_

**Title:** \_\_\_\_\_

**Date:** \_\_\_\_\_

**PRINCE EDWARD COUNTY, VIRGINIA,**  
a political subdivision of the Commonwealth of Virginia

**By:** \_\_\_\_\_

**Name:** \_\_\_\_\_

**Title:** \_\_\_\_\_

**Date:** \_\_\_\_\_

Approved as to form:

By: \_\_\_\_\_  
County Attorney

**EXHIBIT A**

**SCHEDULE OF PAYMENTS**

The following schedule of payments assumes an estimated Project nameplate capacity of 3 MWac, and all payments shall be adjusted proportionally if the nameplate capacity of the constructed Project differs from such estimate.

**Initial Payment:** \$30,000.00 due within six (6) months of the Commercial Operation Date.

Annual Payments:

| Year of Commercial Operation <sup>2</sup> | Annual Payment |
|-------------------------------------------|----------------|
| 1                                         | \$4,200.00     |
| 2                                         | \$4,200.00     |
| 3                                         | \$4,620.00     |
| 4                                         | \$4,620.00     |
| 5                                         | \$4,620.00     |
| 6                                         | \$4,620.00     |
| 7                                         | \$4,620.00     |
| 8                                         | \$5,082.00     |
| 9                                         | \$5,082.00     |
| 10                                        | \$5,082.00     |
| 11                                        | \$5,082.00     |
| 12                                        | \$5,082.00     |
| 13                                        | \$5,590.20     |
| 14                                        | \$5,590.20     |
| 15                                        | \$5,590.20     |
| 16                                        | \$5,590.20     |
| 17                                        | \$5,590.20     |
| 18                                        | \$6,149.22     |
| 19                                        | \$6,149.22     |
| 20                                        | \$6,149.22     |
| 21                                        | \$6,149.22     |
| 22                                        | \$6,149.22     |
| 23                                        | \$6,764.14     |
| 24                                        | \$6,764.14     |
| 25                                        | \$6,764.14     |
| 26                                        | \$6,764.14     |
| 27                                        | \$6,764.14     |
| 28                                        | \$7,440.56     |
| 29                                        | \$7,440.56     |
| 30                                        | \$7,440.56     |
| 31                                        | \$7,440.56     |
| 32                                        | \$7,440.56     |
| 33                                        | \$8,184.61     |
| 34                                        | \$8,184.61     |
| 35                                        | \$8,184.61     |
| 36                                        | \$8,184.61     |
| 37                                        | \$8,184.61     |
| 38                                        | \$9,003.07     |
| 39                                        | \$9,003.07     |
| 40                                        | \$9,003.07     |

Annual Payment for any automatic renewal pursuant to Section 1 of this Agreement: \$9,003.07, escalating at a rate of ten percent (10%) upon the expiration of the forty-second (42<sup>nd</sup>) year of Commercial Operation, and every five (5) years thereafter.

<sup>2</sup> Annual Payment for Commercial Operation year 1 is to be prorated, as applicable, in accordance with Section 2(b) of this Agreement.



**EXHIBIT B**

**SPECIAL USE PERMIT**

**EXHIBIT C**

**FORM OF MEMORANDUM**

*Full exhibit follows*

**PREPARED BY AND RETURN TO:**

**Prince Edward Tax Map ID No. 031-A-16**

**[NOTE TO CLERK: PRINCE EDWARD COUNTY, VIRGINIA, A POLITICAL SUBDIVISION OF THE COMMONWEALTH OF VIRGINIA, IS A PARTY TO THIS INSTRUMENT WHICH, ACCORDINGLY, IS EXEMPT FROM RECORDATION TAX PURSUANT TO VA. CODE SEC. 58.1-811.A.3.]**

**MEMORANDUM OF SOLAR FACILITY SITING AGREEMENT**

This Memorandum of Solar Facility Siting Agreement (this "Memorandum"), dated and effective as of \_\_\_\_\_, 20\_\_\_\_, is made by and between Prince Edward County, Virginia, a political subdivision of the Commonwealth of Virginia (the "County") and Elam Road Solar LLC, a Virginia limited liability company (the "Applicant"), regarding the following:

1. Siting Agreement. The County and the Applicant are parties to that Solar Facility Siting Agreement, dated April 11, 2023 (the "Siting Agreement"), which describes the intent of the Applicant to develop, install, build, and operate a commercial solar photovoltaic (electric energy) generation facility and associated electric grid interconnection facilities ("Project") on that certain parcel of land identified as Prince Edward County Tax Map ID No. 031-A-16 (the "Property").
2. Authorization. The County's execution of the Siting Agreement was authorized during that certain regular meeting of the Board of Supervisors of Prince Edward County on April 11, 2023.
3. Substantially in Accord. The County acknowledges the Planning Commission's determination made on or about March 21, 2023 finding the Project in substantial accord with the County's Comprehensive Plan and hereby accepts, ratifies, and approves of such determination for the reasons stated by the Planning Commission. The County's execution of this Agreement affirms that the Project is substantially in accord with the County's Comprehensive Plan in satisfaction of the requirements of Virginia Code § 15.2-2232. .
4. Obligations. The Siting Agreement sets forth, *inter alia*, certain obligations of the Applicant to comply with the Special Use Permit approved by the County for the Project, and to make certain payments to the County.
5. Siting Agreement Controls. This Memorandum does not supersede, modify, amend or otherwise change the terms, conditions or covenants of the Siting Agreement, and the County and the Applicant executed and are recording this Memorandum solely for the purpose of providing constructive notice of the Siting Agreement and the County's and the Applicant's rights thereunder. The terms, conditions and covenants of the Siting Agreement are incorporated in this Memorandum by reference as though fully set forth herein.
6. Counterparts. This Memorandum may be executed in counterparts, each of which shall be deemed an original and

all of which when taken together shall constitute one and the same document.

WITNESS the following signature and seal:

**PRINCE EDWARD COUNTY, VIRGINIA,**  
a political subdivision of the Commonwealth of Virginia

**By:** \_\_\_\_\_

**Name:** \_\_\_\_\_

**Title:** \_\_\_\_\_

**Date:** \_\_\_\_\_

COMMONWEALTH OF VIRGINIA,  
COUNTY OF \_\_\_\_\_, to-wit:

Before me, a notary public in and for the jurisdiction aforesaid, this \_\_\_\_ day of \_\_\_\_\_, 2023, appeared \_\_\_\_\_, who acknowledged that they executed the foregoing instrument in their capacity as \_\_\_\_\_ of Prince Edward County, Virginia, on behalf of said political subdivision of the Commonwealth of Virginia.

\_\_\_\_\_  
Notary Public

My Commission Expires: \_\_\_\_\_

Notary Registration No. \_\_\_\_\_

WITNESS the following signature and seal:

**Elam Road Solar LLC,**  
a Virginia limited liability company

**By:** \_\_\_\_\_

**Name:** \_\_\_\_\_

**Title:** \_\_\_\_\_

**Date:** \_\_\_\_\_

COMMONWEALTH OF VIRGINIA  
CITY/COUNTY OF \_\_\_\_\_, to wit:

Before me, a notary public in and for the jurisdiction aforesaid, this \_\_\_\_ day of \_\_\_\_\_, 2023, appeared \_\_\_\_\_, who acknowledged that they executed the foregoing instrument in their capacity as \_\_\_\_\_ of Elam Road Solar LLC, a Virginia limited liability company, on behalf of said company.

\_\_\_\_\_  
Notary Public

My Commission Expires: \_\_\_\_\_

Notary Registration No. \_\_\_\_\_

In Re: Public Hearing – Zoning Ordinance Amendment

Chairman Gilliam announced that this was the date and time scheduled for a public hearing to receive citizen input prior to considering an ordinance amendment to amend Appendix B – Zoning of the Prince Edward County Code, with additional definitions of expanded uses and use types, description of development standards, and adjustment of setbacks for accessory structures. Notice of this hearing was advertised according to law in the Wednesday, March 29, 2023, and Wednesday, April 5, 2023 editions of THE FARMVILLE HERALD, a newspaper published in the County of Prince Edward.

Mr. Love stated the Prince Edward County Board of Supervisors requested that staff review all existing County Ordinances and provide updates as necessary in order to comply with the Code of Virginia. Therefore, staff reviewed the existing Prince Edward County Zoning Ordinance as well as researched standards utilized by various rural Counties in their Ordinances and the most recent updates in the Code of Virginia.

At the January and February meetings of the Planning Commission, staff presented a Draft Ordinance with new language and description of development standards. Staff has incorporated all recommendations by the Planning Commission into the Zoning Ordinance Amendment. Significant changes include: adding new definitions for uses such as private camping, short-term tourist rental, and adjusting setbacks for accessory structures in order to allow for public safety.

The Planning Commission held a public hearing on March 21, 2023; no one spoke and the County has received no correspondence concerning the proposed amendment. The Planning Commission unanimously recommended approval of the Ordinance Amendment.

Chairman Gilliam opened the public hearing.

There being no one wishing to speak, Chairman Gilliam closed the public hearing.

Discussion followed on kennels.

Supervisor Emert made a motion, seconded by Supervisor Townsend, to table the Ordinance Amendment to amend and re-ordain Appendix B of the Prince Edward County Code (Zoning) for future review and discussion; the motion carried:

Aye: Pattie Cooper-Jones  
J. David Emert  
Llew W. Gilliam, Jr.  
Victor "Bill" Jenkins  
E. Harrison Jones  
Odessa H. Pride  
Jerry R. Townsend  
Cannon Watson

Nay: None

In Re: Consent Agenda

On motion of Supervisor Townsend, seconded by Supervisor Cooper-Jones, and carried:

Aye: Pattie Cooper-Jones  
J. David Emert  
Llew W. Gilliam, Jr.  
Victor "Bill" Jenkins  
E. Harrison Jones  
Odessa H. Pride  
Jerry R. Townsend  
Cannon Watson

Nay: None

the Board accepted the February 2023 Treasurer's Report; the minutes of the meetings held March 14, 2023 at 5:30 p.m., March 14, 2023 at 7:00 p.m., March 21, 2023 and March 28, 2023; Accounts and Claims, Board Mileage Sheets; and Salaries.

**Prince Edward Treasurer's Report - February 2023**

| Name of Bank                  | Ref # | Int.<br>Rate | Bank Balance    | Available Balance |
|-------------------------------|-------|--------------|-----------------|-------------------|
| Benchmark Pooled Fund Account | 7654  |              | \$19,594,286.05 | \$19,594,286.05   |
| Benchmark Social Services     | 9746  |              | \$190,100.72    | \$190,100.72      |
| Benchmark School Fund         | 3352  |              | \$1,538,583.47  | \$1,538,583.47    |
| Benchmark Food Service        | 3742  |              | \$574,249.55    | \$574,249.55      |
| TOTAL                         |       |              |                 | \$21,897,219.79   |

\*Note: School Fund and Cafeteria Fund balances shown above are estimated balances.

| <b>Certificates of Deposit</b>     |      |      |                |                               |
|------------------------------------|------|------|----------------|-------------------------------|
| Benchmark                          | 0994 | 1.00 | \$122,584.08   |                               |
|                                    | 0995 | 1.00 | \$122,584.08   |                               |
| Recreation Fund                    | 0998 | 0.50 | \$17,529.72    |                               |
| Benchmark 5 Yr CD-letter of credit | 0632 | 1.00 | \$663,114.32   | \$925,812.20                  |
| Benchmark Investment Acct          | L796 | 3.35 | \$2,438,386.88 | \$2,438,386.88                |
| Farmers Bank                       | 2465 | 0.50 | \$109,906.26   |                               |
|                                    | 2466 | 0.50 | \$109,906.26   |                               |
| Underground Storage                | 2478 | 0.60 | \$22,973.65    |                               |
|                                    | 2501 | 2.09 | \$2,248,691.19 |                               |
|                                    | 3418 | 3.75 | \$2,500,000.00 |                               |
|                                    | 3419 | 3.35 | \$2,520,827.78 | \$7,512,305.14                |
| <b>TOTAL</b>                       |      |      |                | <u>\$10,876,504.22</u>        |
| <b>GRAND TOTAL</b>                 |      |      |                | <u><u>\$32,773,724.01</u></u> |

In Re: Highway Matters

Mr. Scott Frederick, VDOT Resident Engineer, P.E., reviewed activities of the VDOT crews:

- Bridge at Worsham, Route 665 has been repaired
- Isham Road, off Rattler's Branch Road, water issue has been addressed
- Peaks Road, water issue has been addressed
- Sinkhole repaired at Pisgah Church Road
- Speed study on Route 600 & Pisgah Church Road is still under review

Mr. Frederick said that VDOT does not have the funding to add additional projects for the next year; he said the funding had to be adjusted at a greater rate than expected, and has cut into the funding for the future. He said he will save the notes from the work session with the Board, but will have to reapprove the existing plan. He requested a public hearing to be held in June on the VDOT Six-Year Plan.

Mr. Frederick then reported that the School Traffic Workgroup has been making progress; he discussed the improvements from the various changes made. He said there will be another meeting on April 21.

Supervisor Pride asked about the traffic pattern at the Middle School. Discussion followed.

Supervisor Pride then questioned if the money saved from the lack of snow removal costs could be used for safety projects, such as on Abilene Road. She asked what happens to that funding. Mr. Frederick said that the snow removal funding is for the entire Commonwealth; he said there are times that it goes back to the district which is then redistributed. Discussion followed.

Chairman Gilliam thanked Mr. Frederick for getting the chevron signs up on Five Forks Road.

Supervisor Emert asked about Spring Creek Road at the railroad crossing; he said two trailers couldn't go over it today. Mr. Frederick said there is no project at this time; the railroad controls that portion of where the road crosses the tracks. He said he is not aware of any plans to upgrade.

Supervisor Emert said that by the time the trucks get [to the crossing], they have no where to go and can't back up. He said there needs to be a sign at the other end [of the road].

In Re: Community Partner Update – Melody Foster, Commonwealth Regional Council

Melody Foster, Executive Director, Commonwealth Regional Council (CRC), gave a brief overview of the organization. She reviewed the services provided and stated through grant writing, the CRC was able to bring in \$25.6 million for the entire region in 2022, and for Prince Edward County, the grants provided \$9.6 million. An additional \$2.6 million was brought in for the region.

Ms. Foster said an Affordable Housing Program has been started for the region; through three housing partners, there are 21 housing units that will be developed by the end of that project, five of which are in Prince Edward County. Another project that Prince Edward County is involved in is the VATI project, which is the initiative of the State to bring broadband to all of Virginia. She stated the CRC also did work on the redistricting process.

Ms. Foster stated there is discussion regarding the development of a new regional economic development organization; five of the seven counties are not a **current** member. A grant from GoVA has been received to have a business plan and strategy developed by the fall.

Ms. Foster announced that an upcoming Freedom of Information Advisory Council Officer Training Workshop will be held May 17 [2023].

Mr. Stanley thanked Ms. Foster and her staff for everything they have done for the County and the citizens; he said they are regarded as an extension of our staff and are appreciated.

In Re: Community Partner Update – Justine Young, Piedmont Senior Resources

Justine Young, Executive Director, Piedmont Senior Resources (PSR), presented an overview of her organization; she discussed several grants that would benefit the County and the region. She said their organization was able to bring approximately \$3.5 million to benefit the region.

Ms. Young said PSR now has approximately 50 employees; she said they have a high retention rate. She said PSR is expanding to meet the additional programs they are now providing in addition to the food distribution and food and vet care for pets. She said there is a new “Doorbell Program” that the food delivery drivers can install to alert the recipients with hearing issues that they have a food delivery and can get to the door to receive the delivery. She said PSR took over a program previously run by the Farmville Ministerial Association that provided assistance with utility bills; she said it is funded by the churches but PSR administers the program for them.

Ms. Young reported that she is on the Executive Committee for the Virginia Area Agencies on Aging Board, the Executive Committee for the Southeastern Area Agencies on Aging Board, and the US Aging Board of Directors. She said this allows her to hear about grant opportunities. She said she has been invited to speak at the Senior Law Day, with Legal Aid; she has been able to participate in a meeting with the State Health Departments to discuss partnerships developed in this area to assist citizens.

Ms. Young thanked the Board for the trust and support over the last few years. She said PSR will hold a fundraiser on May 13, from 10:00 a.m. until 2:00 p.m. at the Prince Edward County Middle School. It is a First Responders event for children in order to give the children a chance to engage firsthand with our Emergency Responders and learn about the equipment.

In Re: Department Updates – Solid Waste (Jeff Jones)

Jeff Jones, Solid Waste General Manager, reported the work on the Rice Convenience Site is progressing. He said that in the month of January, the landfill received 2,798 tons of trash, with 825 truckloads; in February, they received 2,636 tons of trash with 915 truckloads; in March, they received 3,284 tons of trash with over 1,000 truckloads. He said the landfill passed a DEQ stormwater inspection; the new loader is working out well. He said the landfill is in the process of [being able to intake] 175 tons per day to 300 tons per day; he said there have been days when the landfill has reached the 175 ton limit and had to be shut down.

Mr. Jones reported most of the sites have done grading work and added stone; he will go around to power-wash the compactors and pads once it is warmer. The compaction rate allows for 2,060 pounds of trash can be compacted to one square yard [of space in the landfill]. He said everything is running well. He added that they are beginning to plan for the next landfill cell.

In Re: Department Updates – Animal Control (Adam Mumma)

Adam Mumma, Chief Animal Control Officer, reported plans for the future include increasing patrolling and enforcement throughout the County; there will be more intensive response with shorter response time to after-hours calls. He thanked the Sheriff's office for their assistance. He said the Animal Control's Facebook page will allow the department to find good homes for the animals.

In Re: Department Updates – General Services (Randy Cook)

Randy Cook, General Services Director, thanked the Board for its support of the department; he said in the past two and a half years, there have been many improvements made to the maintenance procedures in the Courthouse and other facilities. Projects include:

- New chiller is working well
- Making plans to get our duct system AHUs and VAV boxes cleaned
- Replacing Frequency Drives as needed; replacing filters on a regular schedule
- Met with the State Fire Marshall and are making corrections to Fire doors, exit signs, egress routes, and storage issues
- The Sheriff and Magistrate's doors have been upgraded
- Vented the evidence room, painted, and installed new flooring for the investigator's office
- Working on an announcement system, through the new telephones, for courthouse emergency announcements
- Inspecting panic alarms for proper operation
- The ground floor flooring is almost finished and looking really good
- Painted columns and trim in atrium areas
- Hung hardware for art that Longwood Visual Arts Center will be displaying in courthouse
- Assisted Solid Waste with moving the Rice Convenience Site shed, and installed temporary electrical service to the building
- At DSS:
  - Repaired HVAC #3, and a split system to their IT room.
  - Repaired trouble issues with the Simplex fire alarm system
  - Working on yearly testing quote for the fire alarm system
- At SRR:
  - Completed inspection of the dam and spillway
  - Am in the process of receiving quotes to have the spillway banks cut
  - Making plans to grease and operate the gates on the riser
  - Repainting signs at SRR
  - Coordinating with Prince Edward County student, Barrett Mottor, for a bench and some tree planting at SRR for his Eagle Scout project
- At the AG building:
  - Painting and mulching
  - New sign should be installed soon
  - Plans are being made to renovate front counter.



- At the Cannery:
  - Starting on the re-piping project soon and will be assisting with the procurement of other items included in the cannery grant
- Animal Control
  - Helping Chief Animal Control Officer Mumma keep the shelter up to state standards with painting the runs and any other needs

In Re: Department Updates – Emergency Management (Trey Pyle)

Trey Pyle, Deputy Emergency Management Coordinator, thanked the Board for its support, and said that with their support, Emergency Management has grown and has been able to take on new challenges which have netted positive outcomes to the citizens of the County. He said one example is the search and rescue outcomes. He reported that over the past three months, there have been three searches. He then reported that Prince Edward County and Buckingham Emergency Management will sponsor a VDEM Search & Rescue class to be held at Twin Lakes State Park; he said the initial plan was for 30 students but has been increased. This is a four-series class. He intends to schedule another class for additional participants.

Mr. Pyle said he is continuing to work with the consultant for the Department of Safety Radio System, and closing out the FEMA AFG grant for the SCBA. He submitted another AFG grant for the fire departments for thermal imaging cameras. He then reported the storms that came through did not do significant damage.

In Re: Request from STEPS, Supportive Housing

Mr. Stanley stated the County received a request for \$100,000 of ARPA funding from STEPS for their supportive housing project for the homeless of the region.

As Shawn Rozier advised the Board during STEPS budget presentation of March 21, 2023, STEPS is preparing to sign an MOU with Virginia Supportive Housing (VSH) for the project. Rather than the initial tiny home village that was initially proposed, STEPS has determined that it would be best to construct a 60-80 unit apartment building with an emergency shelter on one floor and supportive housing services for the homeless in the remainder of the facility. STEPS has indicated that they are working with VSH and the Town of Farmville to obtain the necessary approvals for the project.

It is STEPS' intent to request funding from each of the counties in the region to support the project. They are requesting \$100,000 from Prince Edward as the primary user of homeless services in the region, \$75,000 from

Nottoway as the second largest user of such services, and a \$50,000 match from other localities in the region (Buckingham, Cumberland, Amelia, Lunenburg).

Following some discussion, Supervisor Townsend made a motion, seconded by Supervisor Pride, to approve an appropriation of \$100,000 of its ARPA funds for the STEPS Supportive Housing Project, with such approval subject to a \$75,000 match from Nottoway County and participation from each of the other localities in the region, as well as, the location of the project is in the Town of Farmville and necessary zoning approval from the Town of Farmville for the construction of the project is approved; the motion carried:

|             |                                                                                                                                                 |             |                   |
|-------------|-------------------------------------------------------------------------------------------------------------------------------------------------|-------------|-------------------|
| <b>Aye:</b> | Pattie Cooper-Jones<br>J. David Emert<br>Llew W. Gilliam, Jr.<br>Victor "Bill" Jenkins<br>Odessa H. Pride<br>Jerry R. Townsend<br>Cannon Watson | <b>Nay:</b> | E. Harrison Jones |
|-------------|-------------------------------------------------------------------------------------------------------------------------------------------------|-------------|-------------------|

In Re: Authorization of Public Hearing, School CARES Funding

On March 24, 2023, the County Administrator received a letter from the School Board requesting appropriation of \$949,999.64 to the school CARES ACT budget. In order for this transaction to take place, the Board will have to authorize a public hearing to amend the FY23 County and school Budgets by the amount of \$949,999.64 and then appropriate same funds.

Per section 15.2-2507 of the Code of Virginia a locality may amend its budget during the fiscal year. However, if such an amendment exceeds the currently adopted expenditures by one percent or more, then the locality must advertise the amendment at least seven days prior to the public hearing. The County's currently approved FY23 budget is currently \$67,161,030, which means they exceed the one percent threshold.

Supervisor Emert made a motion, seconded by Supervisor Cooper-Jones, to authorize advertisement of a public hearing on the amendment to the school's FY23 CARES Act budget to appropriate funding; the motion carried:

|             |                                                                                                                                                                      |             |      |
|-------------|----------------------------------------------------------------------------------------------------------------------------------------------------------------------|-------------|------|
| <b>Aye:</b> | Pattie Cooper-Jones<br>J. David Emert<br>Llew W. Gilliam, Jr.<br>Victor "Bill" Jenkins<br>E. Harrison Jones<br>Odessa H. Pride<br>Jerry R. Townsend<br>Cannon Watson | <b>Nay:</b> | None |
|-------------|----------------------------------------------------------------------------------------------------------------------------------------------------------------------|-------------|------|

In Re: School CARES Appropriations

Mrs. Stimpson stated that the Board of Supervisors has received a request from the Prince Edward County School Board to appropriate the federal and state funds described below for a total of \$375,000.00 for the 2022-2023 school year. There is no local match required for this appropriation.

Supervisor Emert made a motion, seconded by Supervisor Townsend, to approve the requested FY23 Budget Supplement and appropriate the funds as outlined below; the motion carried:

Aye: Pattie Cooper-Jones                      Nay: None  
J. David Emert  
Llew W. Gilliam, Jr.  
Victor "Bill" Jenkins  
E. Harrison Jones  
Odessa H. Pride  
Jerry R. Townsend  
Cannon Watson

**FY23 BUDGET SUPPLEMENT**

| Rev/Exp | Fund | Dept   | Object | Description        | Debit        | Credit       |
|---------|------|--------|--------|--------------------|--------------|--------------|
| 3 (Rev) | 250  | 033020 | 0101   | School CARES Funds |              | \$375,000.00 |
| 4 (Exp) | 250  | 061000 | 0001   | Instruction        | \$375,000.00 |              |

In Re: Appropriation – Schools Federal Title IV, Part A Funds

Mrs. Stimpson said the Board of Supervisors has received a request from the Prince Edward County School Board to appropriate the federal funds described below for a total of \$1,841.15 for the 2022-2023 school year. There is no local match required for this appropriation, as follows:

**FY23 BUDGET SUPPLEMENT**

| Rev/Exp | Fund | Dept   | Object | Description      | Debit      | Credit     |
|---------|------|--------|--------|------------------|------------|------------|
| 3 (Rev) | 250  | 033020 | 0014   | Title IV, Part A |            | \$1,841.15 |
| 4 (Exp) | 250  | 061000 | 0001   | Instruction      | \$1,841.15 |            |

Supervisor Emert made a motion, seconded by Supervisor Cooper-Jones, to approve the requested FY23 Budget Supplement and appropriate the funds as outlined above; the motion carried:

Aye: Pattie Cooper-Jones                      Nay: None  
J. David Emert  
Llew W. Gilliam, Jr.  
Victor "Bill" Jenkins  
E. Harrison Jones  
Odessa H. Pride  
Jerry R. Townsend  
Cannon Watson

In Re: Four-for-Life Appropriation

Mrs. Stimpson reported the County received a check in the amount of \$17,796.48 from the Virginia Department of Health from the 2021 Four-for-Life program calendar year. These funds, pursuant to § 46.2-694, *Code of Virginia*, shall be used only for emergency medical services.

Supervisor Townsend made a motion, seconded by Supervisor Cooper-Jones, to approve the requested FY23 Budget Supplement and appropriate the funds as outlined below; the motion carried:

Aye: Pattie Cooper-Jones  
J. David Emert  
Llew W. Gilliam, Jr.  
Victor "Bill" Jenkins  
E. Harrison Jones  
Odessa H. Pride  
Jerry R. Townsend  
Cannon Watson

Nay: None

**FY23 BUDGET SUPPLEMENT**

| Rev/Exp | Fund | Dept  | Object | Description                | Debit       | Credit      |
|---------|------|-------|--------|----------------------------|-------------|-------------|
| 3 (Rev) | 100  | 24040 | 0015   | Four-for-Life              |             | \$17,796.48 |
| 4 (Exp) | 100  | 32300 | 7014   | Four-for-Life              | \$17,796.48 |             |
|         |      |       |        | <i>HS First Responders</i> | \$2,000.00  |             |
|         |      |       |        | <i>Meherrin Rescue</i>     | \$3,949.12  |             |
|         |      |       |        | <i>PEVRS</i>               | \$11,847.36 |             |

In Re: Tobacco Region Revitalization Commission Reimbursement

Mrs. Stimpson stated the Commonwealth Regional Council submitted a request for reimbursement through the Tobacco Region Revitalization Commission (TRRC) Grant for the Business Park Road Development Project. The County received two disbursements in March totaling \$255,384.28. The Board is asked to transfer \$255,384.28 from the Economic Development Fund into the General Fund expenditure line to recoup costs previously approved and expended.

Supervisor Emert made a motion, seconded by Supervisor Townsend, to approve the requested FY23 Budget Supplement and appropriate the funds as outlined below; the motion carried:

Aye: Pattie Cooper-Jones  
 J. David Emert  
 Llew W. Gilliam, Jr.  
 Victor "Bill" Jenkins  
 E. Harrison Jones  
 Odessa H. Pride  
 Jerry R. Townsend  
 Cannon Watson

Nay: None

**FY23 BUDGET SUPPLEMENT**

| Rev/Exp | Fund | Dept  | Object | Description              | Debit        | Credit       |
|---------|------|-------|--------|--------------------------|--------------|--------------|
| 3 (Rev) | 100  | 40150 | 0737   | Transfer from Econ Dev   |              | \$255,384.28 |
| 4 (Exp) | 100  | 94000 | 0007   | Business Park Road Dev   | \$255,384.28 |              |
| 3 (Rev) | 737  | 24040 | 0020   | TRRC Reimbursement       |              | \$117,167.00 |
| 3 (Rev) | 737  | 24040 | 0021   | TRRC Reimbursement       |              | \$138,217.28 |
| 4 (Exp) | 737  | 93000 | 0100   | Transfer to General Fund | \$255,384.28 |              |

In Re: County Attorney Update

Mrs. Terri Atkins Wilson, County Attorney, reported the Deed of Easement to the Town of Farmville and the second amendment at Lowe's have been recorded and returned; she said there is a new National Opioid Agreement which has been executed, signed and delivered. She said she worked on the review of the solar siting agreement and review of a Phase I agreement. She reported work continues on projects with the IDA.

Chairman Gilliam asked about the progress on the review of County ordinances. Mrs. Atkins Wilson stated she has been working on several of those. Mr. Stanley said that once the Zoning ordinance is complete, the review is approximately 40% - 50% complete.

In Re: County Administrator Update

Mr. Stanley stated the budget public hearing will be held on April 17 at 7:00 p.m.; he said since the State will not have their budget available until possibly late June, there will not need to be a work session prior to the public hearing.

Mr. Stanley presented his report:

- **Building Inspections Software** – The County and Town Community Development staff participated in a Zoom demonstration on Cloudpermit. Cloudpermit is a software system that would provide a much more modern permit platform for both staff and the contractor community. The software would allow for remote permit applications as well as real-time inspection reporting directly back to the contractor. The software would replace the current Bright System software that the County currently uses. If the Town and County were to both go with the software, it would be an easier transition for the public. We

are also looking at iWorQ Systems, another software vendor and hope to be bringing a recommendation to the Board in the next month. We anticipate being able to cover the Year One costs of the implementation and software costs with our existing Building Inspections and Planning budgets.

- **Emergency Communications System** – In November 2022, Prince Edward County was awarded a \$88,500 State Homeland Security Program Grant – SHSP to help offset the cost of the radio system consultants, CTA, who are assisting the County with the development of a P25 compliant public safety radio system. This grant is 100% federally funded reimbursement grant that requires no local match from the county.

The next phase of the radio project is to allow CTA to move forward with developing a requirements document, based off the selected option of a Trunked UHF Radio System. This will allow Motorola to generate their proposal and cost of the system based off the needs of the County identified by CTA. This phase of the project will be covered by the grant money and will better allow the County to budget and plan moving forward. This process will take in total 9-12 months to complete.

- **Courthouse/Cupola** – Contractor is scheduled to be on-site to paint and repair the cupola the week of April 24<sup>th</sup>.
- **Prince Edward County Industrial Park/Access Road** – Contractor continues to make significant progress on the project. Project completion date is August 10.
- **Solar and the Comprehensive Plan** – The update to the Comprehensive Plan will be able to bring in outside consultants to assist with the solar aspect. The Comp Plan is to be updated every five years; COVID caused a delay. The process will begin in a few months and will likely take a few years to get it completed.

Chairman Gilliam questioned the progress on the GIS system. Mrs. Puckett stated the Public Safety Answering Point (PSAP) boundaries have been completed in the context of public safety. She said work still needs to be completed on parcel data in relation to where certain properties are taxed.

Supervisor Emert questioned ordinance regulations which were not applied to the Special Use Permit application earlier in the meeting. Mr. Stanley said the basic rules and regulations are in place; the Special Use Permit process allows the Board to put additional conditions to address neighborhood impacts on [a project]. Mr. Stanley said they will have to do a site plan and go through that process.

Supervisor Emert asked if [the applicant] knows that and stated an example. Mr. Stanley said the ag exempt [projects] are different from industrial; even they are required to follow ADA requirements. Discussion followed.

Supervisor Emert cited Section 4-200.15: “Any exterior area used for storage, service, maintenance, repair, processing, manufacturing, fabrication, salvage, refuse disposal, or other similar use that is visible from a public street right-of-way or adjoining property, shall be screened with a buffer yard, screening and plantings meeting type A option

1 standards listed in this section, and shall be provided in a manner which screens the use from view. Any area so used shall also be similarly screened from view of adjoining residences and business.” He stated the conditions only call for a six-foot screen. He said it would require a six-foot fence around the entire property.

Mr. Stanley said it would be around the area of outdoor storage and his dumpster. Discussion followed.

Supervisor Watson said it seemed that the discussion is less about making people comply but why would it be articulated if it isn't followed. Supervisor Emert answered to the affirmative, adding that if one person has to follow that standard, all [people] do. Further discussion followed.

#### In Re: Public Safety Radio System

Mr. Trey Pyle stated that as the board is aware, the County was awarded a State Homeland Security Program Grant- SHSP in November 2022 for \$85,500.00. The grant was applied for and awarded to help offset the cost of the radio system consultants, CTA, who are assisting the County with the development of the P25 compliant public safety radio system. This grant is a 100% federally funded reimbursement grant that requires no local match.

CTA has completed the first phase of the project, the review of the current public safety radio systems in the County. They have recommended replacing the multiple systems that are in place with a Countywide P25 UHF Trunked System. This would bring all public safety agencies on a single, shared platform increasing coordination and communications countywide.

The second phase of CTA's project would be to develop the Procurement Document, Evaluation of Proposals, and Contract Analysis. This project will take about six to eight months to complete. This phase would be 100% reimbursed by the SHSP grant funds.

Additionally, the proposed FY 2023-2024 budget includes \$100,000 to begin to allocate anticipated projected project debt service, assuming a 12–15-year lease purchase to fund the communication system.

Supervisor Townsend made a motion, seconded by Supervisor Emert, that the Board approve the request to move forward with Phase 2 of the project to develop a procurement document, evaluation proposals and contract analysis; the motion carried:

Aye: Pattie Cooper-Jones  
J. David Emert  
Llew W. Gilliam, Jr.  
Victor "Bill" Jenkins  
E. Harrison Jones  
Odessa H. Pride  
Jerry R. Townsend  
Cannon Watson

Nay: None

In Re: Health Department – FY 2022-2023 Locality Agreement

Mr. Stanley stated the local Health Department Agreement must be approved each year, even though it comes in over halfway through the fiscal year. He stated the proposed agreement reflects a budget of \$171,490.61 in local matching funds and an additional \$2,385.39 in local funds from FY 2021-2022. As proposed, the cost is \$173,876.00 which has been included in the County's FY 2022-2023 budget.

Supervisor Emert made a motion, seconded by Supervisor Townsend, that the Board approve the FY2022-2023 Locality Agreement between Prince Edward County Board of Supervisors and the Virginia Department of Health for funding and services of the Prince Edward County Health Department as proposed; the motion carried:

Aye: Pattie Cooper-Jones  
J. David Emert  
Llew W. Gilliam, Jr.  
Victor "Bill" Jenkins  
E. Harrison Jones  
Odessa H. Pride  
Jerry R. Townsend  
Cannon Watson

Nay: None

**AGREEMENT BETWEEN THE VIRGINIA DEPARTMENT OF HEALTH AND PRINCE EDWARD COUNTY FOR FUNDING AND SERVICES OF THE PRINCE EDWARD HEALTH DEPARTMENT**

This agreement ("Agreement") for the services to be provided by the Prince Edward Health Department and the funding therefore is by and between the Virginia Department of Health ("VDH") and Prince Edward County Board of Supervisors (collectively "the Parties").

The Agreement is created in satisfaction of the requirements of § 32.1-31 of the Code of Virginia (1950), as amended, in order to operate the Prince Edward Health Department under the terms of this Agreement.

NOW, THEREFORE, in consideration of the covenants and agreements in this Agreement, the sufficiency of which is acknowledged, the Parties agree as follows.

§ 1. VDH, over the course of one fiscal year, will pay an amount not to exceed \$529,505.00, from the state general fund to support the cooperative budget in accordance with, and dependent upon, appropriations by the General Assembly, and in like time frame, the Board of Supervisors of Prince Edward County will provide by appropriation and in equal quarterly payments a sum of \$171,490.61 local matching funds and \$0.00 one-hundred percent local funds for a total of \$0.00 local funds for this fiscal year.



In addition, the Board of Supervisors has approved the Prince Edward County Health Department to carry forward \$2,385.39 in local matching funds for a total of \$173,876.00 matching funds and an additional \$0.00 in one-hundred percent local funds from the prior fiscal year closing locality balance.

These joint funds will be distributed in timely installments, as services are rendered in the operation of the Prince Edward County Health Department, which shall perform public health services in Prince Edward County as indicated in Attachment A(1.), and will perform services required by local ordinances as indicated in Attachment A(2.). Payments from the local government are due on the third Monday of each fiscal quarter.

§ 2. The term of the agreement begins July 1, 2022. This Agreement will be automatically extended on a state fiscal year to year renewal basis under the existing terms and conditions of the Agreement unless timely written notice of termination is provided by either party. Such written notice shall be given at least 60 days prior to the beginning of the fiscal year in which the termination is to be effective.

§ 3. The Commonwealth of Virginia (“Commonwealth”) and VDH shall be responsible for providing liability insurance coverage and will provide legal defense for state employees of the local health department for acts or occurrences arising from performance of activities conducted pursuant to state statutes and regulations.

- A. The responsibility of the Commonwealth and VDH to provide liability insurance coverage shall be limited to and governed by the Commonwealth of Virginia Public Liability Risk Management Plan, established under § 2.2-1837 of the Code of Virginia (1950), as amended. Such insurance coverage shall extend to the services specified in Attachments A(1.) and A(2.), unless the locality has opted to provide coverage for the employee under the Public Officials Liability Self-Insurance Plan, established under § 2.2-1839 of the Code of Virginia (1950), as amended, or under a policy procured by the locality.
- B. The Commonwealth and VDH will be responsible for providing legal defense for those acts or occurrences arising from the performance of those services listed in Attachment A(1.), conducted in the performance of this contract, as provided for under the Code of Virginia and as provided for under the terms and conditions of the Commonwealth of Virginia Public Liability Risk Management Plan.
- C. Services listed in Attachment A(2.), any services performed pursuant to a local ordinance, and any services authorized solely by Title 15.2 of the Code of Virginia (1950), as amended, when performed by a state employee, are herewith expressly exempted from any requirements of legal defense or representation by the Attorney General or the Commonwealth. For purposes of assuring the eligibility of a state employee performing such services for liability coverage under the Commonwealth of Virginia Public Liability Risk Management Plan, the Attorney General has approved, pursuant to § 2.2-507 of the Code of Virginia (1950), as amended, and the Commonwealth of Virginia Public Liability Risk Management Plan, the legal representation of said employee by the city or county attorney, and the Board of Supervisors of Prince Edward County hereby expressly agrees to provide the legal defense or representation at its sole expense in such cases by its local attorney.
- D. In no event shall the Commonwealth or VDH be responsible for providing legal defense or insurance coverage for local government employees.

§ 4. Title to equipment purchased with funds appropriated by the local government and transferred to the Commonwealth, either as match for state dollars or as a purchase under appropriated funds expressly allocated to support the activities of the local health department, will be retained by the Commonwealth and will be entered into the Virginia Fixed Asset Accounting and Control System. Local appropriations for equipment to be locally owned and controlled should not be remitted to the Commonwealth, and the local government's procurement procedures shall apply in the purchase. The locality assumes the responsibility to maintain the equipment and all records thereon.

§ 5. This Agreement may only be amended or otherwise modified by an instrument in writing signed by the Parties.

\_\_\_\_\_  
Robert W. Hicks  
Acting Deputy Commissioner  
Community Health Services  
Virginia Department of Health

\_\_\_\_\_  
Date

\_\_\_\_\_  
Dr. Maria Almond, MD  
District Health Director  
Piedmont Health District

\_\_\_\_\_  
Date

\_\_\_\_\_  
Local authorizing officer signature

Douglas P. Stanley  
Authorizing officer printed name

County Administrator  
Authorizing officer title

\_\_\_\_\_  
Date

Approved as to form by the Office of the Attorney General on July 23, 2018

Attachments: Local Government Agreement, Attachment A(1.)  
Local Government Agreement, Attachment A(2.)

In Re: Animal Warden's Report

Mr. Adam Mumma, Chief Animal Control Officer, submitted a report for the month of March 2023, which was reviewed and ordered to be filed with the Board papers.

In Re: Building Official's Report

Mr. Phillip Moore, Building Inspector, submitted a report for the month of March 2023, which was reviewed and ordered to be filed with the Board papers.

In Re: Cannery – Virginia Food Works

Hannah Evans, Director, submitted a report for the month of March 2023, which was reviewed and ordered to be filed with the Board papers.

In Re: Commonwealth Regional Council Items of Interest

Ms. Melody Foster, Executive Director, submitted a report for the month of March 2023, which was reviewed and ordered to be filed with the Board papers.

On motion of Supervisor Cooper-Jones, seconded by Supervisor Townsend, and adopted by the following vote

|      |                       |           |
|------|-----------------------|-----------|
| Aye: | Pattie Cooper-Jones   | Nay: None |
|      | J. David Emert        |           |
|      | Llew W. Gilliam, Jr.  |           |
|      | Victor "Bill" Jenkins |           |
|      | E. Harrison Jones     |           |
|      | Odessa H. Pride       |           |
|      | Jerry R. Townsend     |           |
|      | Cannon Watson         |           |

the meeting was recessed at 10:15 p.m. until Tuesday, April 18, 2023 at 7:00 p.m.

April 18, 2023

At the special meeting of the Board of Supervisors of Prince Edward County, held at the Court House, thereof, on Tuesday, the 18<sup>th</sup> day of April, 2023; at 7:00 p.m., there were present:

Pattie Cooper-Jones  
J. David Emert  
Llew W. Gilliam, Jr.  
Victor "Bill" Jenkins  
E. Harrison Jones  
Odessa H. Pride  
Jerry R. Townsend  
Cannon Watson

Also present: Douglas P. Stanley, County Administrator; Cheryl Stimpson, Finance Director; and Crystal Baker, Finance Manager.

Chairman Gilliam called the special meeting to order.

Supervisor Jones offered the invocation and led the Pledge of Allegiance.

In Re: Public Hearing – FY 2023-2024 Budget and Tax Rates

Chairman Gilliam announced that this was the date and time scheduled for a public hearing on the proposed 2023-2024 Budget and FY 2023 Tax Rate. Notice of this hearing was advertised according to law in the April 7, 2023 and April 14, 2023 editions of THE FARMVILLE HERALD, a newspaper published in the County of Prince Edward.

Mr. Stanley said following his presentation on the proposed 2023 Tax Levies and FY 2023-2024 Budget, a public hearing would be held on the budget. He said no motion could be made this evening because State law requires localities to wait seven days before the Board can take action; to that end, the Board will meet Tuesday, April 25 at 7:00 p.m. to consider the budget. He said the General Assembly has not yet come back [into session] to consider amendments to the [State] budget, and there are a few unknowns in their final budget; he said the Board has decided to move forward, and may have to hold another public hearing at a later date to amend the County budget.

Mr. Stanley said the Board and staff have been working on the budget since January; he said seven meetings and work sessions have been held specifically on the budget. Mr. Stanley presented final budget notes, as follows:

1. Budget includes an across the board 5.00% Cost of Living Adjustment (COLA) for ALL employees and an additional 2.0% COLA if approved through the State budget for Compensation Board funded positions. In addition, 13 employees have been identified for a 1-4 step merit increase.
2. The proposed budget is balanced at a real estate rate of \$0.51 (\$0.04 increase for CIP) and personal property rate of \$4.50 (current rate).
3. We have included a revised 3.2% increase for the Health Insurance costs. This is a reduction from the original estimate of 5%.
4. Outside agency budgets have been included as recommended by the Board at the March 21st work session.
5. Prince Edward Sheriffs Office:
  - Overtime Increase from \$120,000 to \$175,800
  - Equipment Maintenance from \$85,000 to \$95,000
  - Vehicle Maintenance from \$54,000 to \$75,000
6. Fire and Rescue:
  - VFD contributions up
    - \$74,800 to \$80,000
    - Fuel from \$35,000 to \$40,000
    - Emergency Communications System Upgrade - \$100,000
7. IT Department-To FT (\$40,000+)
8. Planning - Professional Services (\$50,000) -for Comp Plan update
9. Reassessment Increase to go to 4-Year Cycle - (\$75,000 to \$150,000)
10. Legal Services -(\$50,000 to \$75,000)
11. Building Inspections -Funding for lease of new vehicle (\$5,000)
12. Regional Economic Development Initiative - (\$25,000)
13. School CIP Funding -(\$250,000 to \$425,000)
14. School CIP Funding (Meals Tax) - (\$200,000)
15. Solid Waste
  - Paving (\$45,000)
  - New scale house (\$26,000)
  - Equipment (\$20,000 + \$100,224 Debt payment for Loader)
16. CIP - (\$508,708)
17. Sandy River
  - Engineering (\$200,000)
  - Legal (\$17,500)
  - Debt Service (\$725,000)
18. Contingency Funding (\$121,094)

As noted above, the budget was balanced at a real estate (RE) tax rate of \$0.51 and a personal property (PP) rate of \$4.50 based on 100% of the 2023 NADA Clean Loan value assessment. The Board advertised an additional increase \$0.04 in the RE rate to continue to plan for the eventual debt service needed for the Sandy River (\$0.03) and Elementary School (\$0.01) projects.

As advertised, a tax rate cannot be increased unless it is readvertised and a new public hearing held. There is no such requirement if the Board would like to decrease that rate.

Mr. Stanley then reviewed the “Proposed 2023 Tax Levies and FY 2023-2024 Budget Public Hearing” presentation.

Chairman Gilliam opened the public hearing.

Dr. Peter Gur, Farmville District, expressed his support for the County budget and increase in the tax rate to support the schools. He added that he is concerned about school parking, and suggested an additional parking lot at the Elementary School to alleviate congestion. He stated the Sandy River project will benefit the County and would like to see the project extend from Crewe to Hampden-Sydney.

Eric Hodges, Lockett District, expressed his support for the four-cent increase [in the tax rate]. He said the improvements to the schools are necessary, and if approved, asked that a bigger portion of the increase go to the schools.

James E. Ghee, Buffalo District, commended Mr. Stanley on his presentation at the Prince Edward County NAACP meeting last month; he stated that when Mr. Stanley came to this community, Mr. Stanley asked to speak with branch members, and each meeting has been positive and a good step forward. Mr. Ghee stated his concerns regarding broadband, public education and the Sandy River Reservoir, all of which mean a brighter future for our community. He said all have of those concerns are being addressed, and is glad to see the progress made. He added that water is the new gold and those who control the water, control their own future. Mr. Ghee expressed his support for the proposed budget; he added that most of the NAACP membership is on a fixed income but still understand the need to support public education, and that we need to be great innovators with public education within our community and stand ready, willing and able to assist any way we can to make sure we have the best public education division. Mr. Ghee said the organization believes Prince Edward County is on the right track and supports the advertised budget.

Justin Pope, Farmville District, expressed his support of the proposed budget, stating that in doing so, it will show Richmond that the citizens are willing to do their part. He said it also signals to the parents that the community wants to be helpful in the schools; he said test scores are up and two Prince Edward County High School graduates were named Goldwater Scholars, one at Longwood [University] and one at University of Mary Washington. He said it sends a signal to current and future teachers, and to students who will see what is important and what adults value. Mr. Pope said it will send a signal to businesses and families considering locating here as the school system is the most important economic development tool that can be invested in, and is a signal that the community cares about education. It will send a signal to all citizens that the schools are a County’s collective responsibility. He stated Mr. Stanley has done a tremendous job to move the County forward.

Kenneth Fortino, Farmville District, expressed his support of the proposed budget, and stated that as an educator, values public education. He said that to see the schools are struggling and there are challenges, it is important to support the public schools because the struggle harms the students and the financial, social and civic lives of all those in the County. He stated Prince Edward County has one of the lowest real estate tax rates in the Commonwealth, and in maintaining that distinction, while the schools lack the resources that they need, is inappropriate. He thanked the Board for considering correcting that imbalance and moving in the direction where the resources are available. He said supporting the education of the children of this County is the responsibility of the County residents and it is appropriate [for the Board] to ask the citizens of the County to do their part and supply the resources that the School needs. He said if we fulfill this responsibility, it will benefit the County financially and civically far into the future. He encouraged the Board to approve this proposed budget.

Chapman Hood Frazier, Lockett District, expressed his support for the proposed budget. He said he works with students and said the proposed increase is long overdue. He said he sees how hard the teachers are working and he is seeing positive things happen at the schools.

There being no one further wishing to speak, Chairman Gilliam closed the public hearing.

Supervisor Watson asked that those looking at the three cents vs one cent [towards the projects] understand that it does not correlate that much with the project spending. He said this is an internal funding mechanism and is not representative of how much money is being spent on each project.

Supervisor Pride thanked everyone who came to support; she said taxes have not been increased in a while, and in order to see growth, we have to raise taxes at some point.

Chairman Gilliam thanked all for coming to the public hearing. He said there is a lot to consider with the things that are going on in the County; he said the Board tries to make sure we do a good job. He said if the citizens don't think the Board is [doing a good job], he wants to hear about it.

Supervisor Townsend made a motion, seconded by Supervisor Cooper-Jones, to prepare a resolution to honor James C. Moore, past Board of Supervisors member, on his passing; the motion carried unanimously:

|      |                       |           |
|------|-----------------------|-----------|
| Aye: | Pattie Cooper-Jones   | Nay: None |
|      | J. David Emert        |           |
|      | Llew W. Gilliam, Jr.  |           |
|      | Victor "Bill" Jenkins |           |
|      | E. Harrison Jones     |           |
|      | Odessa H. Pride       |           |
|      | Jerry R. Townsend     |           |
|      | Cannon Watson         |           |

On motion of Supervisor Cooper-Jones, seconded by Supervisor Townsend, and adopted by the following vote

|      |                       |           |
|------|-----------------------|-----------|
| Aye: | Pattie Cooper-Jones   | Nay: None |
|      | J. David Emert        |           |
|      | Llew W. Gilliam, Jr.  |           |
|      | Victor "Bill" Jenkins |           |
|      | E. Harrison Jones     |           |
|      | Odessa H. Pride       |           |
|      | Jerry R. Townsend     |           |
|      | Cannon Watson         |           |

the meeting was recessed at 7:42 p.m. until Tuesday, April 25, 2023 at 7:00 p.m.

DRAFT



April 25, 2023

At the special meeting of the Board of Supervisors of Prince Edward County, held at the Court House, thereof, on Tuesday, the 25<sup>th</sup> day of April, 2023; at 7:00 p.m., there were present:

Pattie Cooper-Jones  
J. David Emert  
Llew W. Gilliam, Jr.  
Victor "Bill" Jenkins  
E. Harrison Jones  
Odessa H. Pride  
Jerry R. Townsend  
Cannon Watson

Also present: Douglas P. Stanley, County Administrator; Cheryl Stimpson, Finance Director; and Crystal Baker, Finance Manager.

Chairman Gilliam called the special meeting to order.

Supervisor Cooper-Jones offered the invocation and led the Pledge of Allegiance.

Supervisor Townsend made the following statement:

*As a member of the Prince Edward County Board of Supervisors, I, Jerry R. Townsend, am disclosing that I have a personal interest in the transactions for the adoption of the FY 24 Prince Edward County Budget and the approval of local funding for the FY 24 School Budget. My wife is an employee of the Prince Edward County Public Schools and I am an employee of the Piedmont Regional Jail. I am able to participate pursuant to Section 2.2-3112(B)1 of the Code of Virginia, because the FY 24 Prince Edward County Budget and the local funding for the FY 24 School Budget affects groups of three or more, which are all County-funded employees, all county agencies funded by the County budget and all employees of the Prince Edward County Public Schools. Additionally, I am able to participate in the adoption of the FY 24 County Budget and the approval of local funding for the FY 24 School Budget fairly, objectively and in the public interest. I have filed a declaration of disclosure with the Office of the Prince Edward County Administrator, a copy of which is available for public review.*

In Re: Consideration of 2023 Tax Levies and FY2023-2024 Prince Edward County Budget

Mr. Stanley said the General Assembly has not acted on amendments for the FY 2023-2024 State budget, which will require the Board will have to come back and amend the budget accordingly. He said the House version of the State budget was used as the estimate for State revenue as it is the most conservative [version]; the Virginia Code requires the school budget be approved by May 1.

Mr. Stanley reviewed final budget notes:

:

1. Budget includes an across the board 5.00% Cost of Living Adjustment (COLA) for ALL employees and an additional 2.0% COLA if approved through the State budget for Compensation Board funded positions. In addition, 13 employees have been identified for a 1-4 step merit increase.
2. The proposed budget is balanced at a real estate rate of \$0.51 (\$0.04 increase for CIP) and personal property rate of \$4.50 (current rate).
3. We have included a revised 3.2% increase for the Health Insurance costs. This is a reduction from the original estimate of 5%.
4. Outside agency budgets have been included as recommended by the Board at the March 21st work session.
5. Prince Edward Sheriffs Office:
  - Overtime Increase from \$120,000 to \$175,800
  - Equipment Maintenance from \$85,000 to \$95,000
  - Vehicle Maintenance from \$54,000 to \$75,000
6. Fire and Rescue:
  - VFD contributions up
    - \$74,800 to \$80,000
    - Fuel from \$35,000 to \$40,000
    - Emergency Communications System Upgrade - \$100,000
7. IT Department-To FT (\$40,000+)
8. Planning - Professional Services (\$50,000) -for Comp Plan update
9. Reassessment Increase to go to 4-Year Cycle -(\$75,000 to \$150,000)
10. Legal Services -(\$50,000 to \$75,000)
11. Building Inspections -Funding for lease of new vehicle (\$5,000)
12. Regional Economic Development Initiative - (\$25,000)
13. School CIP Funding -(\$250,000 to \$425,000)
14. School CIP Funding (Meals Tax) - (\$200,000)
15. Solid Waste
  - Paving (\$45,000)
  - New scale house (\$26,000)
  - Equipment (\$20,000 + \$100,224 Debt payment for Loader)
16. CIP - (\$508,708)
17. Sandy River
  - Engineering (\$200,000)
  - Legal (\$17,500)
  - Debt Service (\$725,000)
18. Contingency Funding (\$121,094)

As noted above, the budget was balanced at a real estate (RE) tax rate of \$0.51 and a personal property (PP) rate of \$4.50 based on 100% of the 2023 NADA Clean Loan value assessment. The Board advertised an additional increase of \$0.04 in the RE rate to continue to plan for the eventual debt service needed for the Sandy River (\$0.03) and Elementary School (\$0.01) projects.

Supervisor Townsend made a motion, seconded by Supervisor Cooper-Jones, to adopt the Resolution to Impose Tax Levies for Calendar Year 2023, as advertised; to approve the FY24 Prince Edward County School Budget as proposed

and adopt the Resolution to Approve the FY24 Prince Edward County Budget in the amount of \$69,732,747, as proposed;

the motion carried:

|                                                                                                                                                                                                                                                                                              |                               |
|----------------------------------------------------------------------------------------------------------------------------------------------------------------------------------------------------------------------------------------------------------------------------------------------|-------------------------------|
| <p>Aye:       Pattie Cooper-Jones<br/>                   Llew W. Gilliam, Jr.<br/>                   Victor “Bill” Jenkins<br/>                   E. Harrison Jones<br/>                   Odessa H. Pride<br/>                   Jerry R. Townsend<br/>                   Cannon Watson</p> | <p>Nay:    J. David Emert</p> |
|----------------------------------------------------------------------------------------------------------------------------------------------------------------------------------------------------------------------------------------------------------------------------------------------|-------------------------------|

Mr. Stanley said it will likely be late June until the General Assembly meets to finalize the state budget.

*A Resolution to Impose Tax Levies For Calendar Year 2023*

**Whereas**, the Prince Edward County Board of Supervisors establishes the levies for the County of Prince Edward, Virginia; and

**Whereas**, for calendar year 2023, beginning January 1, 2023 and ending December 31, 2023, the Board of Supervisors has duly advertised and on April 18, 2023 held a public hearing on the subject tax levies;

**Now, Therefore, Be It Resolved**, by the Board of Supervisors of the County of Prince Edward that the following tax levies be, and hereby are, imposed for the calendar year 2023:

| Levy                                                          | Nominal Tax Rate<br><small>(per \$100 of assessed valuation)</small> | Value Used for<br>Assessment Purposes | Effective Tax Rate<br><small>(per \$100 of assessed valuation)</small> |
|---------------------------------------------------------------|----------------------------------------------------------------------|---------------------------------------|------------------------------------------------------------------------|
| Real Estate                                                   | \$0.51                                                               | Fair Market Value                     | \$0.51                                                                 |
| Mobile Homes                                                  | \$0.51                                                               | Fair Market Value                     | \$0.51                                                                 |
| Merchant’s Capital                                            | \$0.70                                                               | 100% of Original Cost                 | \$0.70                                                                 |
| Tangible Personal Property –<br>Motor Vehicles                | \$4.50                                                               | N.A.D.A. Guide, Loan Value            | \$4.50                                                                 |
| Tangible Personal Property –<br>Business Furniture & Fixtures | \$4.50                                                               | 20% of Original Cost                  | \$0.90                                                                 |
| Tangible Personal Property –<br>Heavy Equipment               | \$4.50                                                               | 20% of Original Cost                  | \$0.90                                                                 |
| Machinery & Tools                                             | \$4.20                                                               | 10% of Original Cost                  | \$0.42                                                                 |
| Farm Machinery & Equipment                                    | \$0.00                                                               | ----                                  | \$0.00                                                                 |
| <b>Emergency Medical Service Levy</b>                         |                                                                      |                                       |                                                                        |
| Real Estate                                                   | \$0.01                                                               | Fair Market Value                     | \$0.01                                                                 |
| Mobile Homes                                                  | \$0.01                                                               | Fair Market Value                     | \$0.01                                                                 |
| Tangible Personal Property –<br>Motor Vehicles                | \$0.10                                                               | N.A.D.A. Guide, Loan Value            | \$0.10                                                                 |
| Tangible Personal Property –<br>Business Furniture & Fixtures | \$0.10                                                               | 20% of Original Cost                  | \$0.02                                                                 |
| Tangible Personal Property –<br>Heavy Equipment               | \$0.10                                                               | 20% of Original Cost                  | \$0.02                                                                 |

| <b>Additional Special Levy – Poplar Hill CDA District Only</b> |                                                               |                                               |                                                                 |
|----------------------------------------------------------------|---------------------------------------------------------------|-----------------------------------------------|-----------------------------------------------------------------|
| <b>Levy</b>                                                    | <b>Nominal Tax Rate<br/>(per \$100 of assessed valuation)</b> | <b>Value Used for<br/>Assessment Purposes</b> | <b>Effective Tax Rate<br/>(per \$100 of assessed valuation)</b> |
| Poplar Hill CDA<br>Real Estate Special Levy                    | \$1.00                                                        | Fair Market Value                             | \$1.00                                                          |

***FY 24 Prince Edward County School Budget***

*School Fund* – The total for the School Fund is \$29,088,802, of which \$10,611,786 is local revenue as a transfer from the County General Fund.

*School Cafeteria Fund* – The total for the School Cafeteria Fund is \$1,469,883 of which \$0.00 is local revenue as a transfer from the County General Fund.

*This provides for an overall FY24 Prince Edward County School Budget in the amount of \$30,558,685.*

***A Resolution to Approve the FY24 Prince Edward County Budget***

**WHEREAS**, it is the responsibility of the Prince Edward County Board of Supervisors to approve and control the fiscal plan for the County of Prince Edward, Virginia for Fiscal Year 2024 (FY24); and

**WHEREAS**, on February 22, 2023 the Board of Supervisors provided guidance to the County Administrator on the development of the FY24 Budget; and

**WHEREAS**, on March 14, 2023, the County Administrator submitted to the Board of Supervisors the Proposed FY24 Budget; and

**WHEREAS**, the Board of Supervisors has conducted a total of eight meetings/work sessions on the FY24 County Budget; and

**WHEREAS**, the Board of Supervisors has received citizen input on the proposed budget and proposed tax rates at a duly advertised Public Hearing held April 18, 2023 and

**WHEREAS**, it is the intent of the Board of Supervisors that departments and agencies shall adhere to the budgeted funds in accordance with departmental budgets presented by the County Administrator and amended by the Board of Supervisors;

**NOW, THEREFORE, BE IT RESOLVED**, by the Board of Supervisors of the County of Prince Edward, that the FY24 Budget for Prince Edward County of \$69,732,747 is hereby approved and effective July 1, 2023.

On motion of Supervisor Emert, seconded by Supervisor Townsend, and adopted by the following vote

Aye: Pattie Cooper-Jones  
J. David Emert  
Llew W. Gilliam, Jr.  
Victor "Bill" Jenkins  
E. Harrison Jones  
Odessa H. Pride  
Jerry R. Townsend  
Cannon Watson

Nay: None

the meeting was adjourned at 7:15 p.m.

DRAFT

**[This page intentionally left blank]**



**Board of Supervisors  
Agenda Summary**

**Meeting Date:** May 9, 2023  
**Item #:** 8-c  
**Department:** County Administration  
**Staff Contact:** Crystal Baker  
**Agenda Item:** Review of Accounts & Claims

---

**SUMMARY:**

The Bill List, Mileage Reports, and County Attorney Invoices are attached.

**Cost:**

**Attachments:**

**Recommendation:**

**Sample Motion:**

Motion \_\_\_\_\_  
Second \_\_\_\_\_

Cooper-Jones \_\_\_\_\_  
Emert \_\_\_\_\_

Gilliam \_\_\_\_\_  
Jenkins \_\_\_\_\_  
Jones \_\_\_\_\_

Pride \_\_\_\_\_  
Townsend \_\_\_\_\_  
Watson \_\_\_\_\_

| FUND NO. | DESCRIPTION                       | PAY          |
|----------|-----------------------------------|--------------|
| 100      | GENERAL FUND                      | \$768,602.59 |
| 135      | PUBLIC/PRIVATE EDUCATION ACT FUND | \$4,985.20   |
| 205      | EMS DISTRICT FUND                 | \$58,043.61  |
| 501      | WATER FUND                        | \$1,898.95   |
| 502      | SEWER FUND                        | \$55.60      |
| 520      |                                   | \$62,721.26  |
| 741      | PIEDMONT COURT SERVICES FUND      | \$6,892.98   |
|          | TOTAL                             | 903,200.19   |



| MAJOR# | ACCT# | VENDOR NUMBER        | VENDOR NAME                | INV#            | DESCRIPTION          | AMOUNT       |
|--------|-------|----------------------|----------------------------|-----------------|----------------------|--------------|
| 011010 |       | BOARD OF SUPERVISORS |                            |                 |                      |              |
| 3160   |       | 12818                | Professional Services      |                 |                      |              |
|        |       | 12818                | COMMONWEALTH STRATEGY GROU | 2506            | S/U TAX SCHLS DEC22  | 5,000.00     |
|        |       | 12818                | COMMONWEALTH STRATEGY GROU | 2506            | S/U TAX SCHLS JAN 23 | 5,000.00     |
|        |       | 12818                | COMMONWEALTH STRATEGY GROU | 2579            | S/U TAX SCHLS FEB23  | 5,000.00     |
|        |       |                      |                            |                 | ACCOUNT TOTAL        | 15,000.00 *  |
| 3161   |       | 21756                | Strategic Planning         | 2621            | CITY COMM MARCH 23   | 3,687.50     |
|        |       |                      | LETTERPRESS COMMUNICATIONS |                 | ACCOUNT TOTAL        | 3,687.50 *   |
| 3600   |       |                      | Advertising                |                 |                      |              |
|        |       | 15240                | FARMVILLE NEWSMEDIA        | 129579          | PROGRESS 23          | 527.21       |
|        |       | 15240                | FARMVILLE NEWSMEDIA        | 129579          | INTERSHIP AD         | 129.05       |
|        |       | 15240                | FARMVILLE NEWSMEDIA        | 129579          | B & G EMPLOYMENT AD  | 129.05       |
|        |       | 15240                | FARMVILLE NEWSMEDIA        | 129579          | IT MANAGER EMPL. AD  | 141.34       |
|        |       | 15240                | FARMVILLE NEWSMEDIA        | 129579          | INTERSHIP AD         | 129.04       |
|        |       | 15240                | FARMVILLE NEWSMEDIA        | 129579          | B & G EMPLOYMENT AD  | 129.04       |
|        |       | 15241                | FARMVILLE HERALD           | 222498          | BOS MEETING MARCH 14 | 467.44       |
|        |       |                      |                            |                 | ACCOUNT TOTAL        | 1,652.17 *   |
| 5510   |       |                      | Travel-Mileage             |                 |                      |              |
|        |       | 19819                | JONES, E HARRISON          | REIMB 0423      | MILEAGE REIMBURSEMT  | 294.75       |
|        |       | 25738                | PRIDE ODESSA H             | MILEAGE 0423    | MILEAGE REIMBURSEMT  | 102.84       |
|        |       |                      |                            |                 | ACCOUNT TOTAL        | 397.59 *     |
| 5530   |       |                      | Travel-Subsistence & Lodg  |                 |                      |              |
|        |       | 11250                | BENCHMARK COMMUNITY BANK   | 1563 ADMIN 0423 | MACADO'S BUDGET PLAN | 174.92       |
|        |       | 11250                | BENCHMARK COMMUNITY BANK   | 1563 ADMIN 0423 | MACADO'S BUDGET MTG  | 122.18       |
|        |       |                      |                            |                 | ACCOUNT TOTAL        | 297.10 *     |
| 5540   |       |                      | Travel-Convention & Educa  |                 |                      |              |
|        |       | 11250                | BENCHMARK COMMUNITY BANK   | 1563 ADMIN 0423 | VACO L GILLIAM       | 450.00       |
|        |       | 11250                | BENCHMARK COMMUNITY BANK   | 1563 ADMIN 0423 | VACO-JONES           | 450.00       |
|        |       | 19819                | JONES, E HARRISON          | REIMB 0423 2    | REIMB PARKING        | 25.00        |
|        |       |                      |                            |                 | ACCOUNT TOTAL        | 925.00 *     |
| 6040   |       | 31339                | ADP Equipment              | 242374982       | CELL PHONE           | 583.63       |
|        |       |                      | VERIZON WIRELESS           | 0423            | ACCOUNT TOTAL        | 583.63 *     |
|        |       |                      | COUNTY ADMINISTRATOR       |                 | MAJOR TOTAL          | 22,542.99 ** |
| 012110 |       |                      |                            |                 |                      |              |
| 3160   |       | 28062                | Professional Services      | 582016          | BOWMAN ZONING APPEAL | 19,394.47    |
|        |       |                      | SANDS ANDERSON PC          | 107766          | ACCOUNT TOTAL        | 19,394.47 *  |
| 5230   |       | 31339                | Telecommunications         | 242374982       | CELL PHONE           | 90.58        |
|        |       |                      | VERIZON WIRELESS           | 0423            | ACCOUNT TOTAL        | 90.58 *      |
| 5530   |       | 11250                | Travel-Subsistence & Lodg  | 1555 ADMIN 0423 | CHAMBER OF COMM LCH  | 10.00        |
|        |       | 11250                | BENCHMARK COMMUNITY BANK   | 1555 ADMIN 0423 | BRKFST IDA MEETING   | 7.17         |
|        |       |                      |                            |                 | ACCOUNT TOTAL        | 17.17 *      |

| MAJOR#<br>ACCT# | VENDOR<br>NUMBER | VENDOR<br>NAME                                        | INV#           | DESCRIPTION                        | ACCOUNT TOTAL | AMOUNT       |
|-----------------|------------------|-------------------------------------------------------|----------------|------------------------------------|---------------|--------------|
| 5540            | 11250            | BENCHMARK COMMUNITY BANK<br>Travel-Convention & Educa | 1555           | ADMIN 0423<br>PARKING-ROANOKE      | 8.00 *        | 8.00 *       |
| 5810            | 11250            | BENCHMARK COMMUNITY BANK<br>Dues & Association Member | 1563           | ADMIN 0423<br>RENWL NOTARY-C BAKER | 45.00         | 45.00 *      |
| 6001            | 10259            | AMAZON CAPITAL SERVICES<br>Office Supplies            | 1H9D-VHPG-F3GL | USB CABLE                          | 5.08          | 5.08         |
|                 | 10259            | AMAZON CAPITAL SERVICES                               | 1H9D-VHPG-F3GL | LUNAR BLUE PAPER                   | 17.73         | 17.73        |
|                 | 10259            | AMAZON CAPITAL SERVICES                               | 1H9D-VHPG-F3GL | LASER INDEX DIVIDERS               | 28.85         | 28.85        |
|                 | 10259            | AMAZON CAPITAL SERVICES                               | 1H9D-VHPG-F3GL | CLEAR PAPER TRAYS                  | 65.00         | 65.00        |
|                 | 10259            | AMAZON CAPITAL SERVICES                               | 1H9D-VHPG-F3GL | IVORY RESUME PAPER                 | 19.84         | 19.84        |
|                 | 10259            | AMAZON CAPITAL SERVICES                               | 1H9D-VHPG-F3GL | RED CARDSTOCK                      | 16.49         | 16.49        |
|                 | 10259            | AMAZON CAPITAL SERVICES                               | 1H9D-VHPG-F3GL | HAND SOAP                          | 8.90          | 8.90         |
|                 | 10259            | AMAZON CAPITAL SERVICES                               | 1H9D-VHPG-F3GL | CERT/DOC COVERS                    | 34.13         | 34.13        |
|                 | 10259            | AMAZON CAPITAL SERVICES                               | 1H9D-VHPG-F3GL | MAGNIFYING GLASS                   | 12.74         | 12.74        |
|                 | 10259            | AMAZON CAPITAL SERVICES                               | 1H9D-VHPG-F3GL | INDEX DIVIDERS                     | 28.85         | 28.85        |
|                 | 10259            | AMAZON CAPITAL SERVICES                               | 1H9D-VHPG-F3GL | BIRTHDAY CARD ASSRT                | 12.99         | 12.99        |
|                 | 10259            | AMAZON CAPITAL SERVICES                               | 1H9D-VHPG-F3GL | BIRTHDAY CARDS                     | 16.39         | 16.39        |
|                 | 10259            | AMAZON CAPITAL SERVICES                               | 1H9D-VHPG-F3GL | PIGMENT FINELINERS                 | 10.97         | 10.97        |
|                 | 10259            | AMAZON CAPITAL SERVICES                               | 1H9D-VHPG-F3GL | SHIPPING                           | 10.28         | 10.28        |
|                 | 10259            | AMAZON CAPITAL SERVICES                               | 1Q3K-3VMH-F9KC | PAPER FOR GIFT BOX                 | 15.95         | 15.95        |
|                 | 10259            | AMAZON CAPITAL SERVICES                               | 1Q3K-3VMH-F9KC | MED GIFT BOX                       | 27.60         | 27.60        |
|                 | 10259            | AMAZON CAPITAL SERVICES                               | 1Q3K-3VMH-F9KC | PAPER FOR GIFT BOX                 | 15.95         | 15.95        |
|                 | 10259            | AMAZON CAPITAL SERVICES                               | 1Q3K-3VMH-F9KC | MED GIFT BOX                       | 27.60         | 27.60        |
|                 | 10259            | AMAZON CAPITAL SERVICES                               | 1Q3K-3VMH-F9KC | GIFT BAGS                          | 13.75         | 13.75        |
|                 | 10259            | AMAZON CAPITAL SERVICES                               | 1Q3K-3VMH-F9KC | GIFT BAG BUNDLE                    | 13.75         | 13.75        |
|                 | 10259            | AMAZON CAPITAL SERVICES                               | 1Q3K-3VMH-F9KC | DISPOSABLE PLATES                  | 24.59         | 24.59        |
|                 | 10259            | AMAZON CAPITAL SERVICES                               | 1Y94-9XTF-DMFH | CREDIT POLY MAILERS                | 10.00-        | 10.00-       |
|                 | 11250            | BENCHMARK COMMUNITY BANK                              | 1563           | ADMIN 0423<br>FILE CABINET-KARIN   | 192.28        | 192.28       |
|                 | 11902            | BUSINESS DATA OF VA, INC.                             | 01-2278        | NORTON RENWL-CBAKER                | 44.99         | 44.99        |
|                 | 13369            | DIAMOND SPRINGS WATER INC                             | 3062           | 3584191<br>WATER COOLER RENT       | 8.95          | 8.95         |
|                 | 13369            | DIAMOND SPRINGS WATER INC                             | 3062           | 3614720<br>5 GL WATER              | 26.72         | 26.72        |
|                 | 20600            | KEY OFFICE SUPPLY                                     | 415            | 577020<br>FILE CABINET             | 88.87         | 88.87        |
|                 | 31351            | VERNON COMPANY                                        | 2602328        | RI<br>SHIPPING                     | 237.35        | 237.35       |
| 6011            | 31351            | VERNON COMPANY<br>Uniforms & Wearing Appare           | 2602328        | RI<br>SHIPPING                     | 1,016.59 *    | 1,016.59 *   |
|                 | 31351            | VERNON COMPANY                                        | 2602328        | RI<br>SHIPPING                     | 118.95        | 118.95       |
|                 | 31351            | VERNON COMPANY                                        | 2602328        | RI<br>SHIPPING                     | 602.94        | 602.94       |
|                 | 31351            | VERNON COMPANY                                        | 2602328        | RI<br>SHIPPING                     | 52.20         | 52.20        |
| 6012            | 11250            | BENCHMARK COMMUNITY BANK<br>Books and Subscriptions   | 1563           | ADMIN 0423<br>START MEETING        | 17.28         | 17.28        |
|                 | 22950            | CIVICPLUS, LLC                                        | 257864         | FULL SVC SUPPLE SUBS               | 6,201.03      | 6,201.03     |
| 012210          | LEGAL SERVICES   |                                                       |                |                                    | 6,218.31 *    | 6,218.31 *   |
| 3160            | 28062            | SANDS ANDERSON PC<br>Professional Services            | 582015         | 106962<br>REDISTRICTING            | 27,564.21 **  | 27,564.21 ** |



| MAJOR#<br>ACCT#<br>5510 | VENDOR<br>NUMBER                | VENDOR<br>NAME                | INVOICE#        | DESCRIPTION          | AMOUNT      |
|-------------------------|---------------------------------|-------------------------------|-----------------|----------------------|-------------|
| 6001                    | 11730 BRYANT AMY                | Travel-Mileage                | MILEAGE 0323    | TRAIN/NOTTOWAY TREAS | 31.37       |
|                         | 11730 BRYANT AMY                |                               | MILEAGE 0323 2  | TAV MEETING SPRING   | 70.60       |
|                         | 25602 POWELL, JENNA             |                               | MILEAGE 0323    | TAV DIST MTG 2023    | 85.80       |
|                         |                                 |                               |                 | ACCOUNT TOTAL        | 187.77 *    |
| 6014                    | 10259 AMAZON CAPITAL SERVICES   | Office Supplies               | 1JXJ-7MX6-FPLV  | OFFICE CHAIR         | 116.00      |
|                         | 11250 BENCHMARK COMMUNITY BANK  |                               | 2777 TREAS 0423 | MAHOGANY PIC FRAME   | 54.40       |
|                         | 20600 KEY OFFICE SUPPLY         |                               | 433 576416      | PENS/CARTRIDGES      | 339.33      |
|                         | 20600 KEY OFFICE SUPPLY         |                               | 433 576417      | COPY PAPER           | 159.98      |
|                         | 20600 KEY OFFICE SUPPLY         |                               | 433 576464      | PENS                 | 22.89       |
|                         |                                 |                               |                 | ACCOUNT TOTAL        | 692.60 *    |
| 6020                    | 28866 STEPS, INC                | Other Operating Supplies      | 17845           | SHREDDING            | 53.50       |
|                         | 13012 DMV                       | DMV Stops                     | 2023090000776   | DMV STOP FEES        | 53.50 *     |
|                         |                                 |                               |                 | ACCOUNT TOTAL        | 2,450.00    |
|                         |                                 |                               |                 | MAJOR TOTAL          | 2,450.00 *  |
| 012510                  |                                 | INFORMATION TECHNOLOGY        |                 |                      | 3,427.47 ** |
| 3160                    |                                 | Professional Services         |                 |                      |             |
|                         | 11902 BUSINESS DATA OF VA, INC. |                               | 01-2278         | TRAVEL & EXPENSE     | 125.00      |
|                         | 11902 BUSINESS DATA OF VA, INC. |                               | 01-2279         | TRAVEL & EXPENSE     | 125.00      |
|                         | 11902 BUSINESS DATA OF VA, INC. |                               | 01-2280         | TRAVEL & EXPENSE     | 125.00      |
|                         | 11902 BUSINESS DATA OF VA, INC. |                               | 01-2281         | TRAVEL & EXPENSE     | 125.00      |
|                         | 11902 BUSINESS DATA OF VA, INC. |                               | 01-2282         | TRAVEL & EXPENSE     | 125.00      |
|                         | 11902 BUSINESS DATA OF VA, INC. |                               | 01-2283         | TRAVEL & EXPENSE     | 125.00      |
|                         | 11902 BUSINESS DATA OF VA, INC. |                               | 01-2284         | TRAVEL & EXPENSE     | 125.00      |
|                         | 11902 BUSINESS DATA OF VA, INC. |                               | 01-2285         | TRAVEL & EXPENSE     | 125.00      |
|                         | 11902 BUSINESS DATA OF VA, INC. |                               | 01-2286         | TRAVEL & EXPENSE     | 125.00      |
|                         | 11902 BUSINESS DATA OF VA, INC. |                               | 01-2287         | TRAVEL & EXPENSE     | 125.00      |
|                         | 11902 BUSINESS DATA OF VA, INC. |                               | 01-2288         | TRAVEL & EXPENSE     | 125.00      |
|                         | 11902 BUSINESS DATA OF VA, INC. |                               | 01-2289         | TRAVEL & EXPENSE     | 125.00      |
|                         | 11902 BUSINESS DATA OF VA, INC. |                               | 01-2290         | TRAVEL & EXPENSE     | 125.00      |
|                         | 11902 BUSINESS DATA OF VA, INC. |                               | 01-2291         | TRAVEL & EXPENSE     | 125.00      |
|                         | 11902 BUSINESS DATA OF VA, INC. |                               | 01-2292         | TRAVEL & EXPENSE     | 125.00      |
|                         | 11902 BUSINESS DATA OF VA, INC. |                               | 01-2293         | TRAVEL & EXPENSE     | 125.00      |
|                         | 11902 BUSINESS DATA OF VA, INC. |                               | 01-2294         | TRAVEL & EXPENSE     | 125.00      |
|                         | 11902 BUSINESS DATA OF VA, INC. |                               | 01-2295         | TRAVEL & EXPENSE     | 125.00      |
|                         | 11902 BUSINESS DATA OF VA, INC. |                               | 01-2298         | TRAVEL & EXPENSE     | 125.00      |
|                         | 11902 BUSINESS DATA OF VA, INC. |                               | 01-2303         | TRAVEL & EXPENSE     | 125.00      |
|                         | 11902 BUSINESS DATA OF VA, INC. |                               | 01-2313         | TRAVEL & EXPENSE     | 125.00      |
|                         | 11902 BUSINESS DATA OF VA, INC. |                               | 01-2320         | TRAVEL & EXPENSE     | 125.00      |
|                         |                                 |                               |                 | ACCOUNT TOTAL        | 7,125.00 *  |
|                         |                                 |                               |                 | MAJOR TOTAL          | 7,125.00 ** |
| 013100                  |                                 | ELECTORAL BOARD AND OFFICIALS |                 |                      |             |
| 3320                    | 28587 SOUTHERN COPIER           | Maintenance Service Contr     | 230405-0070     | EQUIP SVC CONTRACT   | 300.00      |
|                         |                                 |                               |                 | ACCOUNT TOTAL        | 300.00 *    |

| MAJOR#<br>ACCT# | VENDOR<br>NUMBER | VENDOR<br>NAME            | DESCRIPTION           | INV#           | AMOUNT      |
|-----------------|------------------|---------------------------|-----------------------|----------------|-------------|
| 3600            | 15241            | FARMVILLE HERALD          | Advertising           | 130369 1603237 | 221.22      |
|                 | 15241            | FARMVILLE HERALD          | Advertising           | 130369 1624505 | 165.92      |
|                 |                  |                           | POLL LOC CHNG PRC701  |                | 387.14 *    |
|                 |                  |                           | ACCOUNT TOTAL         |                |             |
| 5210            | 32961            | Postal Services           | POSTG ELEC DATA       | REIMB 0423     | 30.80       |
|                 |                  |                           |                       |                | 30.80 *     |
| 5510            | 10173            | Mileage                   | MILEAGE HTL ROANOKE   | REIMB 0323 3   | 162.83      |
|                 |                  |                           |                       |                | 162.83 *    |
| 5530            | 10173            | Travel-Subsistence & Lodg | MEALS VEBA CONF       | REIMB 0323     | 74.44       |
|                 | 10173            | AKERS-BOOKER GWENDOLYN    | HOTEL VEBA CONF       | REIMB 0323 2   | 554.85      |
|                 |                  |                           |                       |                | 629.29 *    |
|                 |                  |                           | ACCOUNT TOTAL         |                | 1,510.06 ** |
|                 |                  |                           | MAJOR TOTAL           |                |             |
| 021100          |                  | CIRCUIT COURT             |                       |                |             |
| 6001            | 20600            | Office Supplies           | LGL PDS/BRKRM SUPPLS  | 8868 576221    | 203.26      |
|                 | 20600            | KEY OFFICE SUPPLY         | COFFEE                | 8868 576341    | 44.22       |
|                 | 20600            | KEY OFFICE SUPPLY         | CANDY                 | 8868 576362    | 28.20       |
|                 | 20600            | KEY OFFICE SUPPLY         | CANDY                 | 8868 576363    | 26.47       |
|                 |                  |                           | ACCOUNT TOTAL         |                | 302.15 *    |
| 6012            | 21426            | Books & Subscriptions     | 1YR DIGITAL SUBSCRIPT | 6778942-B2     | 399.00      |
|                 |                  |                           |                       |                | 399.00 *    |
|                 |                  |                           | ACCOUNT TOTAL         |                | 701.15 **   |
|                 |                  |                           | MAJOR TOTAL           |                |             |
| 021200          |                  | GENERAL DISTRICT COURT    |                       |                |             |
| 3160            | 13369            | Professional Services     | WATER COOLER RENT     | 10479 3473704  | 11.95       |
|                 | 13369            | DIAMOND SPRINGS WATER INC | (3) 5GL WATER         | 10479 3481105  | 26.72       |
|                 | 13369            | DIAMOND SPRINGS WATER INC | (3) 5GL WATER         | 10479 3563176  | 26.72       |
|                 | 13369            | DIAMOND SPRINGS WATER INC | WATER COOLER RENT     | 10479 3588216  | 11.95       |
|                 | 13369            | DIAMOND SPRINGS WATER INC | (3) 5 GL WATER        | 10479 3652638  | 26.72       |
|                 | 13369            | DIAMOND SPRINGS WATER INC | WATER COOLER RENT     | 10479 3673821  | 11.95       |
|                 | 28866            | STEPS, INC                | DESTRUCTION BOX       | 17755          | 42.80       |
|                 | 28866            | STEPS, INC                | SHREDDING BOX         | 17843          | 42.80       |
|                 |                  |                           | ACCOUNT TOTAL         |                | 201.61 *    |
| 6001            | 20600            | Office Supplies           | DIVIDERS              | 424 576764     | 59.95       |
|                 |                  |                           |                       |                | 59.95 *     |
|                 |                  |                           | ACCOUNT TOTAL         |                | 261.56 **   |
|                 |                  |                           | MAJOR TOTAL           |                |             |
| 021250          |                  | JUVENILE & DOMESTIC COURT |                       |                |             |
| 3160            | 28866            | Professional Services     | SHREDDING             | 17844          | 21.40       |
|                 |                  |                           |                       |                | 21.40 *     |

| MAJOR#<br>ACCT# | VENDOR<br>NUMBER | VENDOR<br>NAME             | INV#           | DESCRIPTION          | ACCOUNT TOTAL | AMOUNT      |
|-----------------|------------------|----------------------------|----------------|----------------------|---------------|-------------|
| 3320            | 26125            | QUADIENT LEASING USA, INC. | N9869648       | LEASE PAYMENT        | 449.89 *      | 449.89 *    |
| 6001            | 13369            | DIAMOND SPRINGS WATER INC  | 12135 3563221  | (1) 5GL WATER        | 11.54         | 11.54       |
|                 | 13369            | DIAMOND SPRINGS WATER INC  | 12135 3588995  | WATER COOLER RENT    | 23.49 *       | 23.49 *     |
|                 |                  |                            |                |                      | 494.78 **     | 494.78 **   |
| 021300          |                  | SPECIAL MAGISTRATES        |                |                      |               |             |
| 5230            | 31339            | VERIZON WIRELESS           | 242374982 0423 | CELL PHONE           | 40.29 *       | 40.29 *     |
|                 |                  |                            |                |                      | 40.29 **      | 40.29 **    |
| 021600          |                  | CLERK OF THE CIRCUIT COURT |                |                      |               |             |
| 5230            | 21319            | BRIGHTSPEED                | 309863799 0323 | PHONE CLERK OFFICE   | 61.35         | 61.35 *     |
| 5850            |                  | Jurors/Witnesses           |                |                      |               |             |
|                 |                  |                            | GJ JUROR 0423  | SGJ JUROR            | 30.00         | 30.00       |
|                 |                  |                            | GJ JUROR 0423  | SGJ JUROR            | 60.00         | 60.00       |
|                 |                  |                            | GJ JUROR 0423  | SGJ JUROR            | 30.00         | 30.00       |
|                 |                  |                            | GJ JUROR 0423  | SGJ JUROR            | 30.00         | 30.00       |
|                 |                  |                            | GJ JUROR 0423  | SGJ JUROR            | 30.00         | 30.00       |
|                 |                  |                            | GJ JUROR 0423  | SGJ JUROR            | 30.00         | 30.00       |
|                 |                  |                            |                |                      | 240.00 *      | 240.00 *    |
| 6001            |                  | Office Supplies            |                |                      |               |             |
|                 | 13369            | DIAMOND SPRINGS WATER INC  | 11151 3563178  | 5 GL WATER           | 32.72         | 32.72       |
|                 | 13369            | DIAMOND SPRINGS WATER INC  | 11151 3588520  | WATER COOLER RENT    | 9.95          | 9.95        |
|                 | 13369            | DIAMOND SPRINGS WATER INC  | 11151 3614722  | 5 GL WATER           | 19.13         | 19.13       |
|                 | 20600            | KEY OFFICE SUPPLY          | 576415         | HAND TOWELS          | 108.38        | 108.38      |
|                 | 20600            | KEY OFFICE SUPPLY          | 576738         | (4) CHAIRS           | 1,139.56      | 1,139.56    |
|                 | 20600            | KEY OFFICE SUPPLY          | 576739         | INK PENS             | 21.12         | 21.12       |
|                 | 20600            | KEY OFFICE SUPPLY          | 576919         | USB HUB              | 15.99         | 15.99       |
|                 | 20600            | KEY OFFICE SUPPLY          | 576920         | PENS/MSE/SPKRS/SLEVE | 149.30        | 149.30      |
|                 |                  |                            |                |                      | 1,496.15 *    | 1,496.15 *  |
| 6012            | 29038            | T&N PRINTING               | 451899         | PLATS                | 24.94         | 24.94 *     |
|                 |                  |                            |                |                      | 24.94 *       | 24.94 *     |
|                 |                  |                            |                |                      | 1,822.44 **   | 1,822.44 ** |
| 021800          |                  | LAW LIBRARY                |                |                      |               |             |
| 6012            | 22211            | RELX INC. DBA LEXIS NEXIS  | 3094398261     | MARCH PAYMENT        | 403.00        | 403.00 *    |
|                 |                  |                            |                |                      | 403.00 **     | 403.00 **   |

| MAJOR#<br>ACCT# | VENDOR<br>NUMBER<br>NAME                              | INVOICE#        | DESCRIPTION          | AMOUNT     |
|-----------------|-------------------------------------------------------|-----------------|----------------------|------------|
| 5230            | 11902 BUSINESS DATA OF VA, INC.<br>Telecommunications | 01-2289         | NORTON RENWL-CWA     | 89.98      |
|                 |                                                       |                 |                      | 89.98 *    |
| 5899            | 28866 STEPS, INC<br>Miscellaneous                     | 17840           | SHRED SERVICE        | 21.40      |
|                 | 9999999 HOLLY MANOR                                   | SENIOR LAW DAY  | HALF OF CATERING     | 117.92     |
|                 |                                                       |                 |                      | 139.32 *   |
| 6001            | 11250 BENCHMARK COMMUNITY BANK<br>Office Supplies     | 2256 CWA 0423   | NTEPD/FASTNRS/STAMP  | 116.27     |
|                 | 13369 DIAMOND SPRINGS WATER INC                       | 17594 3563177   | (3) 5 GAL SPRING     | 26.95      |
|                 | 13369 DIAMOND SPRINGS WATER INC                       | 17594 3563219   | CREDIT (2) 5GL SPRNG | 15.33-     |
|                 | 13369 DIAMOND SPRINGS WATER INC                       | 17594 3614721   | (1) 5GL WATER        | 11.62      |
|                 | 13369 DIAMOND SPRINGS WATER INC                       | 17594 3652639   | (1) 5GL WATER        | 11.62      |
|                 | 13369 DIAMOND SPRINGS WATER INC                       | 17594 3676382   | WATER COOLER RENT    | 15.85      |
|                 | 20600 KEY OFFICE SUPPLY                               | 6 576171        | BLUE PENS            | 21.12      |
|                 | 20600 KEY OFFICE SUPPLY                               | 6 576172        | PENS/MARKR/CORRTP/FL | 87.13      |
|                 | 29992 TUCKER, TIA                                     | REIMB 0423      | REIMB NOTARY LIC FEE | 45.00      |
|                 |                                                       |                 |                      | 320.23 *   |
|                 |                                                       |                 |                      | 549.53 **  |
| 031200 SHERIFF  |                                                       |                 | ACCOUNT TOTAL        |            |
| 3110            | 28596 SOUTHERN STATES<br>Animal Care/Services         | 1208670         | DOG FOOD             | 38.99      |
|                 |                                                       |                 |                      | 38.99 *    |
| 3311            | 11005 B&G AUTO INC<br>Repairs & Maint-Auto & Eq       | 19062           | STATE INSPECTION     | 20.00      |
|                 | 14300 EAST END MOTOR CO INC                           | 0225432         | REPLACE CONVERTERS   | 2,217.11   |
|                 | 14300 EAST END MOTOR CO INC                           | 0226099         | BATTERY              | 15.60      |
|                 | 14915 EXPRESS CARE                                    | 21698           | OIL CHNG/WPR BLADES  | 149.96     |
|                 | 14915 EXPRESS CARE                                    | 22071           | OIL CHANGE           | 111.96     |
|                 | 14915 EXPRESS CARE                                    | 22144           | OIL CHANGE           | 103.98     |
|                 | 14915 EXPRESS CARE                                    | 22484           | OIL CHANGE           | 85.97      |
|                 | 14915 EXPRESS CARE                                    | 23131           | OIL CHANGE           | 103.98     |
|                 | 14915 EXPRESS CARE                                    | 23135           | OIL CHANGE           | 85.97      |
|                 | 14915 EXPRESS CARE                                    | 23203           | OIL CHANGE           | 93.98      |
|                 | 14915 EXPRESS CARE                                    | 23438           | OIL CHANGE           | 93.98      |
|                 | 29199 THIRD STREET WRECKER INC                        | T11402          | WRECKER SERVICE      | 119.97     |
|                 | 29199 THIRD STREET WRECKER INC                        | T11453          | WRECKER SERVICE      | 252.60     |
|                 |                                                       |                 |                      | 150.00     |
|                 |                                                       |                 |                      | 3,519.09 * |
| 3320            | 10102 AT&T MOBILITY<br>Maintenance Service Contr      | 82451 0323      | GPS MONTHLY SERVICE  | 432.76     |
|                 | 18661 ID NETWORKS                                     | 280562          | HRDWARE MAINT FEE    | 224.00     |
|                 | 21320 CENTURYLINK                                     | 101365904       | 911 PLAN COVERAGE    | 2,300.45   |
|                 | 21767 LEXISNEXIS RISK DATA MANAG                      | 692908320230331 | ACCURANT MTHLY CHG   | 132.61     |
|                 | 28587 SOUTHERN COPIER                                 | 230322-0010     | METER CHARGE         | 137.57     |
|                 | 28587 SOUTHERN COPIER                                 | 230322-0011     | MAINT SERVICE CONTR  | 315.00     |
|                 |                                                       |                 |                      | 432.76     |
|                 |                                                       |                 |                      | 224.00     |
|                 |                                                       |                 |                      | 2,300.45   |
|                 |                                                       |                 |                      | 132.61     |
|                 |                                                       |                 |                      | 137.57     |
|                 |                                                       |                 |                      | 315.00     |

| MAJOR#<br>ACCT# | VENDOR<br>NUMBER<br>NAME                                                                                                                                                                                                                                                                                          | DESCRIPTION               | INV#                                                                                                                                              | DESCRIPTION                                                                                                                                                             | AMOUNT                                                                                               |
|-----------------|-------------------------------------------------------------------------------------------------------------------------------------------------------------------------------------------------------------------------------------------------------------------------------------------------------------------|---------------------------|---------------------------------------------------------------------------------------------------------------------------------------------------|-------------------------------------------------------------------------------------------------------------------------------------------------------------------------|------------------------------------------------------------------------------------------------------|
| 5230            | 28587 SOUTHERN COPIER<br>31339 VERIZON WIRELESS                                                                                                                                                                                                                                                                   | Telecommunications        | 230405-0046<br>9931175526                                                                                                                         | METER CHARGE<br>MDT MONTHLY CHARGE                                                                                                                                      | 100.94<br>1,042.57<br>4,685.90 *                                                                     |
|                 |                                                                                                                                                                                                                                                                                                                   |                           |                                                                                                                                                   | ACCOUNT TOTAL                                                                                                                                                           |                                                                                                      |
| 5510            | 10102 AT&T MOBILITY<br>20904 KINEX NETWORKING SOLUTION<br>21319 BRIGHTSPEED<br>21319 BRIGHTSPEED<br>21319 BRIGHTSPEED<br>21319 BRIGHTSPEED                                                                                                                                                                        | Travel-Mileage            | 677451 0323<br>2304-0016941<br>309468839 0423<br>309558628 0423<br>489989564 0323<br>489989564 0423                                               | CELLULAR SERVICE<br>RMT BU/FIBER CONN<br>VCIN<br>PHONE<br>SALLY PORT LINE<br>SALLY PORT LINE                                                                            | 1,291.15<br>119.95<br>10.36<br>7.97<br>82.91<br>82.39<br>1,594.73 *                                  |
|                 |                                                                                                                                                                                                                                                                                                                   |                           |                                                                                                                                                   | ACCOUNT TOTAL                                                                                                                                                           |                                                                                                      |
| 5530            | 27604 ROACH, ABBY                                                                                                                                                                                                                                                                                                 | Travel-Subsistence & Lodg | MILEAGE FEB-MAR                                                                                                                                   | MLGE REIMB FEB-MARCH                                                                                                                                                    | 915.69<br>915.69 *                                                                                   |
| 5801            | 11894 BUSINESS CARD                                                                                                                                                                                                                                                                                               | Accreditation             | 0555SHERIFF0323                                                                                                                                   | TRANSMITTERS                                                                                                                                                            | 56.53<br>56.53 *                                                                                     |
|                 |                                                                                                                                                                                                                                                                                                                   |                           |                                                                                                                                                   | ACCOUNT TOTAL                                                                                                                                                           |                                                                                                      |
| 5810            | 20600 KEY OFFICE SUPPLY                                                                                                                                                                                                                                                                                           | Dues & Association Member | 545 576769                                                                                                                                        | HANGING FOLDERS                                                                                                                                                         | 199.90<br>199.90 *                                                                                   |
|                 |                                                                                                                                                                                                                                                                                                                   |                           |                                                                                                                                                   | ACCOUNT TOTAL                                                                                                                                                           |                                                                                                      |
| 6001            | 18851 INTERNATIONAL ASSOCIATION                                                                                                                                                                                                                                                                                   | Office Supplies           | M23-C669651                                                                                                                                       | IAPE MEMBERSHP DUES                                                                                                                                                     | 65.00<br>65.00 *                                                                                     |
|                 |                                                                                                                                                                                                                                                                                                                   |                           |                                                                                                                                                   | ACCOUNT TOTAL                                                                                                                                                           |                                                                                                      |
| 6004            | 11894 BUSINESS CARD<br>11902 BUSINESS DATA OF VA, INC.<br>11902 BUSINESS DATA OF VA, INC.<br>13369 DIAMOND SPRINGS WATER INC<br>13369 DIAMOND SPRINGS WATER INC<br>13369 DIAMOND SPRINGS WATER INC<br>20600 KEY OFFICE SUPPLY<br>20600 KEY OFFICE SUPPLY<br>20600 KEY OFFICE SUPPLY<br>21153 CAPITAL ONE/ WALMART | Office Supplies           | 0555SHERIFF0323<br>01-2278<br>01-2294<br>12832 3563180<br>12832 3589290<br>12832 3614719<br>545 576117<br>545 576249<br>545 576962<br>636325 0323 | TRANSMITTERS<br>NORTON RENWL-SHERIFF<br>NORTON RENWL-SHERIFF<br>(3) 5GL WATER<br>WATER COOLER RENT<br>(3) 5GL WATER<br>FOLDERS<br>CUPS<br>COPY PAPER<br>OFFICE SUPPLIES | 14.99<br>44.99<br>44.99<br>24.80<br>24.90<br>24.80<br>96.68<br>230.38<br>244.95<br>36.70<br>788.18 * |
|                 |                                                                                                                                                                                                                                                                                                                   |                           |                                                                                                                                                   | ACCOUNT TOTAL                                                                                                                                                           |                                                                                                      |
| 6009            | 28640 SOUTHSIDE ELECTRIC COOP<br>28869 STIFF O INC<br>14300 EAST END MOTOR CO INC<br>14300 EAST END MOTOR CO INC<br>14300 EAST END MOTOR CO INC<br>14915 EXPRESS CARE<br>15721 FISHER AUTO PARTS, INC.<br>21153 CAPITAL ONE/ WALMART                                                                              | Virso Comm Center Crime P | 526776002 0323<br>10410<br>0225459<br>0226013<br>0226466<br>22322<br>056-318575<br>636325 0323                                                    | VIRSO ELECT SERVICE<br>PORTA JOHN VIRSO<br>TIRES/MOUNT/BALANCE<br>TIRES/MOUNT/BALANCE<br>(1) TIRE/MNT/BALANCE<br>WIPER BLADES<br>CAR BATTERY<br>VEHICLE SUPPLIES        | 16.30<br>680.00<br>696.30 *<br>638.56<br>722.88<br>147.42<br>55.98<br>227.09<br>66.83<br>1,858.76 *  |
|                 |                                                                                                                                                                                                                                                                                                                   |                           |                                                                                                                                                   | ACCOUNT TOTAL                                                                                                                                                           |                                                                                                      |
| 6010            | 10259 AMAZON CAPITAL SERVICES                                                                                                                                                                                                                                                                                     | Police Supplies           | 1T4C-P9G3-73J6                                                                                                                                    | FOLDING TABLES                                                                                                                                                          | 67.09                                                                                                |



| MAJOR#<br>ACCT# | VENDOR<br>NUMBER<br>NAME                                                   | DESCRIPTION          | INV#            | AMOUNT       |
|-----------------|----------------------------------------------------------------------------|----------------------|-----------------|--------------|
| 6011            | 28432 SIRCHIE ACQUISITION COMPAN<br>Uniforms & Wearing Appare<br>GALLS LLC | EVIDENCE BAGS        | 0584584-IN      | 284.01 *     |
|                 | 16102 GALLS LLC                                                            |                      | 023795441       | 96.81        |
|                 | 16102 GALLS LLC                                                            |                      | 023904387       | 147.50       |
|                 | 27153 READ'S UNIFORMS LLC                                                  |                      | 181098-99       | 97.58        |
| 6025            | NRA Grant                                                                  | ACCOUNT TOTAL        |                 | 341.89 *     |
|                 | 10259 AMAZON CAPITAL SERVICES                                              | TOURNIQUET HOLDER    | 1KND-YQTN-17RD  | 209.90       |
|                 | 10259 AMAZON CAPITAL SERVICES                                              | TRAINING TOURNIQUETS | 1KND-YQTN-17RD  | 147.99       |
|                 | 10259 AMAZON CAPITAL SERVICES                                              | SHIPPING             | 1KND-YQTN-17RD  | 6.99         |
| 6030            | Non-Capital Equipment<br>BUSINESS CARD                                     | ACCOUNT TOTAL        |                 | 364.88 *     |
|                 | 11894 BUSINESS CARD                                                        | TRANSMITTERS         | 0555SHERIFF0323 | 932.77       |
| 032200          | VOLUNTEER FIRE DEPARTMENT                                                  | ACCOUNT TOTAL        |                 | 932.77 *     |
|                 | Payment to Rice VFD                                                        | MAJOR TOTAL          |                 | 16,342.62 ** |
| 7002            | 12845 GFL/COUNTY WASTE                                                     | TRASH COLLECTION     | KD0000228213    | 90.86        |
|                 | 14695 ELLINGTON'S LAWN SERVICE                                             | MOWING               | 108             | 75.00        |
|                 | 15656 FIRE & SAFETY EQUIP CO                                               | NOSECUP ASSY         | 118239 RVFD     | 51.52        |
|                 | 27490 RUNDSTROM AUTO LLC                                                   | OIL CHNG/REPL SENSOR | RICEFD 02132023 | 284.80       |
|                 | 28597 SOUTHERN STATES COOP INC                                             | LP GAS BULK          | P882464 RVFD    | 309.00       |
|                 | 31846 DOMINION ENERGY VIRGINIA                                             | RVFD ELECTRIC        | 4500495009 0423 | 82.39        |
|                 | 32734 WITMER PUBLIC SAFETY GRP                                             | MENS SHIRTS          | INV232734       | 84.09        |
| 7003            | Payment to Prospect VFD                                                    | ACCOUNT TOTAL        |                 | 977.66 *     |
|                 | 14700 ELLINGTON ENERGY SERVICE                                             | RPR/SVC EMERG GENER  | 38084 PVFD      | 497.11       |
|                 | 14801 ESO SOLUTIONS, INC                                                   | CELL PHONE PAGING    | ESO-84675 PVFD  | 300.00       |
|                 | 15721 FISHER AUTO PARTS, INC.                                              | HEADLIGHT            | 056-317355 PVFD | 18.69        |
|                 | 15908 FOSTER FUELS INC                                                     | PROPANE/LP GAS       | 1283942 PVFD    | 677.42       |
|                 | 15908 FOSTER FUELS INC                                                     | PROPANE/LP GAS       | 1317391 PVFD    | 492.05       |
|                 | 16651 GOODMAN SPECIALIZED                                                  | INSP/REPAIR/SERVICE  | 17959G PVFD     | 1,685.11     |
|                 | 16651 GOODMAN SPECIALIZED                                                  | INSP/SERVICE/REPAIR  | 18024G PVFD     | 998.37       |
|                 | 16658 GOODMAN TRUCK & TRACTOR                                              | LEAK REPAIR INTL7500 | 135169 PVFD     | 2,570.81     |
|                 | 20600 KEY OFFICE SUPPLY                                                    | INK CARTRIDGES       | 577208 PFVD     | 214.00       |
|                 | 22468 MID-ATLANTIC IRRIGATION                                              | REPRS TO MINI PUMPER | 212250 PVFD     | 3,253.97     |
|                 | 25210 PAMPLIN EXXON                                                        | REPLC 2 BATT CHEV TK | 50031 PVFD      | 473.70       |
|                 | 25210 PAMPLIN EXXON                                                        | STATE INSPECTION     | 50259 PVFD      | 20.00        |
|                 | 32926 WRIGHT AUTO SUPPLY                                                   | BATTERY FOR TRUCK    | 248199 PVFD     | 273.24       |
| 7004            | Payment to Darlington VFD                                                  | ACCOUNT TOTAL        |                 | 11,474.47 *  |
|                 | 12996 CYRUS PEST CONTROL CO                                                | PEST CONTROL         | FEB 2023 DHVFD  | 45.00        |
|                 | 28640 SOUTHSIDE ELECTRIC COOP                                              | DHVFD ELECTRIC       | 38156001 0423   | 250.52       |
| 7005            | Payment to Hampden-Sydney<br>BRAME SPECIALTY CO INC                        | ACCOUNT TOTAL        |                 | 295.52 *     |
|                 | 11493 BRAME SPECIALTY CO INC                                               | XTREME WASH/WAX      | 7808349 HSVFD   | 72.75        |

| MAJOR#<br>ACCT# | VENDOR<br>NUMBER | VENDOR<br>NAME             | INV#                   | DESCRIPTION          | AMOUNT              |            |
|-----------------|------------------|----------------------------|------------------------|----------------------|---------------------|------------|
| 7006            | 11772            | BUG BUSTERS PEST CONTROL   | 842999                 | MNTHLY PEST CONTROL  | 48.15               |            |
|                 | 12024            | C W WILLIAMS               | 652156                 | HOSE                 | 317.85              |            |
|                 | 15560            | FARMVILLE WMSALE ELECTRIC  | 760740                 | LIGHT BULBS          | 209.90              |            |
|                 | 21319            | BRIGHTSPEED                | 310187773              | PHONE HSVFD          | 77.73               |            |
|                 | 25366            | PIEDMONT FLEET SERVICE     | 01FC2980               | FINANCE CHARGE       | 69.21               |            |
|                 | 25366            | PIEDMONT FLEET SERVICE     | 01FC3025               | FINANCE CHARGE       | 70.60               |            |
|                 | 25366            | PIEDMONT FLEET SERVICE     | 01S317857              | RPR TANKER 26        | 2,227.98            |            |
|                 | 25366            | PIEDMONT FLEET SERVICE     | 01S318098              | RPR ENGINE 21        | 1,232.64            |            |
|                 | 31846            | DOMINION ENERGY VIRGINIA   | 8350720002             | ELECTRIC HSVFD       | 340.35              |            |
|                 | 32926            | WRIGHT AUTO SUPPLY         | 251276                 | WPR BLDS/WINDSHLD WS | 38.93               |            |
|                 |                  |                            | Payment to Pamplin VFD |                      | ACCOUNT TOTAL       | 4,706.09 * |
|                 |                  | 25210                      | PAMPLIN EXXON          | 49953                | INSPECTION          | 20.00      |
|                 |                  | 25210                      | PAMPLIN EXXON          | 49957                | INSPECTION KENWORTH | 51.00      |
|                 |                  |                            |                        | ACCOUNT TOTAL        | 71.00 *             |            |
| 7007            | 16658            | GOODMAN TRUCK & TRACTOR    | 442087                 | GASKET ENGINE 5      | 49.15               |            |
|                 | 31421            | VACORP                     | 103386                 | WORKERS COMP         | 2,601.25            |            |
|                 |                  |                            |                        | ACCOUNT TOTAL        | 2,650.40 *          |            |
| 7013            | 10169            | FIRE Programs/ATL-Prospec  | 20984                  | HOSES                | 3,859.84            |            |
|                 | 15656            | FIRE & SAFETY EQUIP CO     | 119606                 | SAFETY VESTS         | 89.98               |            |
|                 | 31359            | VEST'S SALE & SERVICE INC  | 15857                  | GPR GLOVES           | 662.62              |            |
|                 |                  |                            |                        | ACCOUNT TOTAL        | 4,612.44 *          |            |
|                 | 7041             | 25210                      | PAMPLIN EXXON          | 2854                 | FUEL                | 17.82      |
|                 |                  | 25210                      | PAMPLIN EXXON          | 4062                 | DIESEL              | 40.00      |
|                 |                  | 25210                      | PAMPLIN EXXON          | 4478                 | DIESEL              | 77.87      |
|                 |                  | 25210                      | PAMPLIN EXXON          | 5359                 | DIESEL              | 61.53      |
|                 |                  | 25210                      | PAMPLIN EXXON          | 5450                 | DIESEL              | 147.58     |
|                 |                  | 25210                      | PAMPLIN EXXON          | 6418                 | REGULAR CA          | 17.70      |
| 25210           |                  | PAMPLIN EXXON              | 6692                   | REGULAR CA           | 79.00               |            |
| 25246           |                  | PARKER OIL CO INC          | 425359                 | DIESEL MVFR          | 1,353.03            |            |
| 25246           |                  | PARKER OIL CO INC          | 446661                 | DIESEL MVFR          | 1,012.37            |            |
| 25782           |                  | PRINCE EDWARD CO PBLIC SCH | PVD DIESEL 0123        | PVD DIESEL           | 290.80              |            |
| 25782           |                  | PRINCE EDWARD CO PBLIC SCH | PVD DIESEL 0223        | PVD DIESEL           | 383.89              |            |
| 29440           |                  | PRINCE EDWARD CO TREAS     | PVD DIESEL 1222        | PVD DIESEL           | 18.59               |            |
| 29440           |                  | PRINCE EDWARD CO TREAS     | PVD GAS 0123           | PVD GAS              | 61.62               |            |
| 29440           |                  | PRINCE EDWARD CO TREAS     | PVD GAS 0223           | PVD GAS              | 92.01               |            |
| 29440           |                  | PRINCE EDWARD CO TREAS     | PVD GAS 1222           | PVD GAS              | 20.42               |            |
|                 |                  |                            |                        | ACCOUNT TOTAL        | 3,674.23 *          |            |
|                 |                  |                            |                        | MAJOR TOTAL          | 28,461.81 **        |            |
| 032500          |                  | EMERGENCY SERVICES         |                        |                      |                     |            |
| 3160            |                  | Professional Service E-91  |                        |                      |                     |            |
|                 | 29280            | TIMMONS GROUP              | 310931                 | PEC ADDR DATA MAINT  | 187.50              |            |
|                 |                  |                            |                        | ACCOUNT TOTAL        | 187.50 *            |            |
|                 |                  |                            |                        | MAJOR TOTAL          | 187.50 **           |            |

| MAJOR# | VENDOR NUMBER | VENDOR NAME                                         | INV#            | DESCRIPTION           | AMOUNT        |
|--------|---------------|-----------------------------------------------------|-----------------|-----------------------|---------------|
| 033200 | 25380         | Piedmont Regional Jail-Pe<br>PIEDMONT REGIONAL JAIL | 4200            | INMATE DAYS 4TH QTR   | 237,834.74 *  |
| 7001   |               |                                                     |                 |                       | 237,834.74 *  |
|        |               |                                                     |                 |                       | 237,834.74 ** |
| 034100 |               | BUILDING OFFICIAL                                   |                 |                       |               |
| 5230   | 31339         | Telecommunications<br>VERIZON WIRELESS              | 242374982 0423  | CELL PHONE            | 40.29 *       |
|        |               |                                                     |                 |                       | 40.29 *       |
|        |               |                                                     |                 |                       | 40.29 **      |
| 035100 |               | ANIMAL CONTROL                                      |                 |                       |               |
| 3110   |               | Vet Care                                            |                 |                       |               |
|        | 27524         | RIDGE ANIMAL HOSPITAL                               | 346296          | VET CARE              | 101.20        |
|        | 27524         | RIDGE ANIMAL HOSPITAL                               | 347164          | VET CARE              | 207.76        |
|        | 27524         | RIDGE ANIMAL HOSPITAL                               | 347964          | VET CARE              | 969.68        |
|        | 27524         | RIDGE ANIMAL HOSPITAL                               | 348241          | VET CARE              | 861.41        |
|        | 27524         | RIDGE ANIMAL HOSPITAL                               | 348244          | VET CARE              | 49.36         |
|        | 27524         | RIDGE ANIMAL HOSPITAL                               | 348452          | VET CARE              | 321.33        |
|        | 57504         | RICHMOND SPCA                                       | MAR-23          | VET CARE              | 365.00        |
|        |               |                                                     |                 |                       | 2,875.74 *    |
| 3310   | 13730         | Repairs/Maintenance<br>DODSON BROS EXTERMINATING    | 719313 0323     | PEST CNTRL ACO        | 50.00 *       |
|        |               |                                                     |                 |                       | 50.00 *       |
| 3311   | 14300         | Repairs & Maint-Auto & Po<br>EAST END MOTOR CO INC  | 0226460         | INSP/OIL CHANGE F250  | 121.32        |
|        | 14300         | EAST END MOTOR CO INC                               | 226356          | FLAT TIRE REPAIR      | 22.00         |
|        |               |                                                     |                 |                       | 143.32 *      |
| 5230   |               | Telecommunications<br>AMAZON CAPITAL SERVICES       | 163L-JGMK-9YLR  | IPHONE SCREEN PROTECT | 8.99          |
|        | 21319         | BRIGHTSPEED                                         | 310119726 0423  | ANIMAL CONTROL        | 139.08        |
|        | 31339         | VERIZON WIRELESS                                    | 242374982 0423  | CELL PHONE            | 80.58         |
|        |               |                                                     |                 |                       | 228.65 *      |
| 5899   | 11250         | Miscellaneous<br>BENCHMARK COMMUNITY BANK           | 1563 ADMIN 0423 | VACA LAWBOOK          | 39.50         |
|        | 21811         | LOWE'S                                              | 913329-KRMGSU   | (6) BGS TOPSOIL       | 14.10         |
|        |               |                                                     |                 |                       | 53.60 *       |
| 6001   | 10259         | Office Supplies<br>AMAZON CAPITAL SERVICES          | 163L-JGMK-9YLR  | WTHR PROOF NOTEBOOK   | 24.50         |
|        | 10259         | AMAZON CAPITAL SERVICES                             | 163L-JGMK-9YLR  | FIELD NOTEBOOK        | 12.30         |
|        | 10259         | AMAZON CAPITAL SERVICES                             | 163L-JGMK-9YLR  | 6 PK POCKET NOTEBOOK  | 15.99         |
|        |               |                                                     |                 |                       | 52.79 *       |
| 6002   | 11250         | Supplies for Shelter<br>BENCHMARK COMMUNITY BANK    | 1563 ADMIN 0423 | PATTERSON VET SUPPLY  | 24.84         |
|        | 28596         | SOUTHERN STATES                                     | 1207660         | (4) BAGS DOGFOOD      | 147.96        |

| MAJOR#<br>ACCT# | VENDOR<br>NUMBER | VENDOR<br>NAME                                    | DESCRIPTION          | INV#            | AMOUNT      |
|-----------------|------------------|---------------------------------------------------|----------------------|-----------------|-------------|
| 6011            | 28596            | SOUTHERN STATES                                   | DOG FOOD (1)         | 1210894         | 209.29 *    |
|                 |                  | Uniforms and Wearing Appa                         |                      |                 |             |
|                 | 11250            | BENCHMARK COMMUNITY BANK                          | BOOTS-ACO            | 1563 ADMIN 0423 | 65.94       |
|                 | 11250            | BENCHMARK COMMUNITY BANK                          | WORK PANTS-ACO       | 1563 ADMIN 0423 | 157.92      |
|                 | 22166            | CREATIVE MONOGRAMMING                             | UNIFORMS FOR ADAM M  | 15704           | 429.00      |
|                 |                  |                                                   | ACCOUNT TOTAL        |                 | 652.86 *    |
|                 |                  |                                                   | MAJOR TOTAL          |                 | 4,266.25 ** |
| 035300          |                  | MEDICAL EXAMINER                                  |                      |                 |             |
| 3110            | 29459            | Professional Health Serv<br>TREASURER OF VIRGINIA | CORONER              | ELMER, JAMES J  | 20.00       |
|                 |                  |                                                   | ACCOUNT TOTAL        |                 | 20.00 *     |
|                 |                  |                                                   | MAJOR TOTAL          |                 | 20.00 **    |
| 042610          |                  | SANDY RIVER RESERVOIR                             |                      |                 |             |
| 3160            | 29415            | Professional Services<br>TRC ENGINEERS INC.       | 50% DAM INSPECTION   | 106212 540139   | 3,300.00    |
|                 |                  |                                                   | ACCOUNT TOTAL        |                 | 3,300.00 *  |
|                 |                  |                                                   | MAJOR TOTAL          |                 | 3,300.00 ** |
| 043200          |                  | GENERAL PROPERTIES                                |                      |                 |             |
| 3310            |                  | Repairs/Maintenance                               |                      |                 |             |
|                 | 12408            | CHEMTREAT INC                                     | MONTHLY SVC APRIL 23 | CIN10489034     | 133.75      |
|                 | 12744            | COMFORT SYSTEMS USA                               | RPR COMPRESSR DSS    | 125441          | 325.00      |
|                 | 13730            | DODSON BROS EXTERMINATING                         | PEST CNTRL CANNERY   | 158003 0323     | 39.00       |
|                 | 13730            | DODSON BROS EXTERMINATING                         | PEST CNTRL FRMVL RD  | 158005 0323     | 39.00       |
|                 | 13730            | DODSON BROS EXTERMINATING                         | PEST CNTRL CRTHSE    | 158007 0323     | 85.00       |
|                 | 13730            | DODSON BROS EXTERMINATING                         | PEST CNTRL VISTR CTR | 158010 0323     | 39.00       |
|                 | 16915            | GULLY TAVERN LANDSCAPING                          | LANDSCAPE CONTRACT   | 6377            | 650.00      |
|                 | 16915            | GULLY TAVERN LANDSCAPING                          | LANDSCAPE CONTRACT   | 6378            | 650.00      |
|                 | 16915            | GULLY TAVERN LANDSCAPING                          | LANDSCAPE CONTRACT   | 6379            | 650.00      |
|                 | 16915            | GULLY TAVERN LANDSCAPING                          | LAWN PRGM FERTILIZER | 6380            | 61.39       |
|                 | 16915            | GULLY TAVERN LANDSCAPING                          | LAWN PRGM FERTILIZER | 6381            | 61.39       |
|                 | 16915            | GULLY TAVERN LANDSCAPING                          | LAWN PRGM FERTILIZER | 6382            | 61.39       |
|                 | 16915            | GULLY TAVERN LANDSCAPING                          | LANDSCAPE 0423       | 6393            | 650.00      |
|                 | 25352            | PHELPS LOCKSMITH SERVICE                          | INST/SVC LATCHES     | 1227            | 465.00      |
|                 | 29242            | TK ELEVATOR CORPORATION                           | FULL MAINT APR-JUNE  | 3007150270      | 3,393.16    |
|                 |                  |                                                   | ACCOUNT TOTAL        |                 | 7,303.08 *  |
| 3311            |                  | Repairs & Maint-Auto & Eq                         |                      |                 |             |
|                 | 14278            | EAST COAST EMERGENCY VEHIC                        | AMBER MAG MOUNT BAR  | 32483           | 271.00      |
|                 | 27490            | RUNDSTROM AUTO LLC                                | OIL CHNG/INSP/PLG TR | PECPW 04032023  | 171.63      |
|                 |                  |                                                   | ACCOUNT TOTAL        |                 | 442.63 *    |
| 5110            |                  | Electrical Services                               |                      |                 |             |
|                 | 28640            | SOUTHSIDE ELECTRIC COOP                           | SANDY RIVER ELECT    | 114379002 0423  | 25.60       |
|                 | 31846            | DOMINION ENERGY VIRGINIA                          | STEPS                | 4883315659 0423 | 992.47      |

| MAJOR#<br>ACCT# | VENDOR<br>NUMBER | VENDOR<br>NAME            | DESCRIPTION          | INV#            | AMOUNT        |
|-----------------|------------------|---------------------------|----------------------|-----------------|---------------|
| 5130            | 31846            | DOMINION ENERGY VIRGINIA  | LIGHTS AT RICE       | 6669158583 0323 | 1,753.83      |
|                 | 31846            | DOMINION ENERGY VIRGINIA  | AG BUILDING          | 8105475944 0423 | 2,917.22 *    |
|                 |                  |                           |                      |                 | ACCOUNT TOTAL |
| 5230            | 29332            | Water & Sewer             |                      |                 |               |
|                 | 29332            | TOWN OF FARMVILLE         | WATER & SEWER        | AG BLDG 0323    | 63.84         |
|                 | 29332            | TOWN OF FARMVILLE         | WATER                | CH LAWN 0323    | 12.29         |
|                 | 29332            | TOWN OF FARMVILLE         | WATER & SEWER        | STEPS 0323      | 105.43        |
|                 | 29332            | TOWN OF FARMVILLE         | WATER & SEWER        | 56 SMI WAY 0323 | 55.50         |
|                 |                  |                           |                      |                 | 237.06 *      |
|                 |                  |                           |                      |                 | ACCOUNT TOTAL |
| 5440            | 10105            | Telecommunications        |                      |                 |               |
|                 | 21319            | AT&T                      | LONG DIST CITY SHOP  | 7305055660 0423 | 47.36         |
|                 | 21319            | BRIGHTSPEED               | COUNTY SHOP          | 310262069 0423  | 74.25         |
|                 | 21319            | BRIGHTSPEED               | ELEVATOR             | 310441360 0323  | 122.70        |
|                 | 31339            | VERIZON WIRELESS          | CELL PHONE           | 242374982 0423  | 40.29         |
|                 |                  |                           |                      |                 | 284.60 *      |
|                 |                  |                           |                      |                 | ACCOUNT TOTAL |
| 6001            | 28869            | Portable Toilet Rental    |                      |                 |               |
|                 | 19946            | STIFF O O INC             | MONTHLY SERVICE      | 10392           | 125.00        |
|                 | 20600            | Office Supplies           | BUSINESS CARDS-COOK  | 8317            | 62.45         |
|                 | 13367            | JUDY ELLINGTON DESIGN     | FLASH DRIVE          | 415 577176      | 10.99         |
|                 | 13367            | DIAMOND PAPER COMPANY     |                      |                 | 73.44 *       |
|                 | 21811            | DIAMOND PAPER COMPANY     |                      |                 |               |
|                 | 30239            | LOWE'S                    | JANITORIAL SUPPLIES  | 314923          | 1,379.45      |
|                 | 30239            | UNIFIRST CORPORATION      | JANITORIAL SUPPLIES  | 315602          | 1,455.42      |
|                 | 30239            | UNIFIRST CORPORATION      | JANITORIAL SUPPLIES  | 906753-KTQWYS   | 16.95         |
|                 |                  |                           | JANITORIAL SUPPLIES  | 1680064709      | 47.95         |
|                 |                  |                           | JANITORIAL SUPPLIES  | 1680066996      | 47.95         |
|                 |                  |                           |                      |                 | 2,947.72 *    |
|                 |                  |                           |                      |                 | ACCOUNT TOTAL |
| 6007            | 10259            | Repairs and Maintenance S |                      |                 |               |
|                 | 11250            | AMAZON CAPITAL SERVICES   | TOILET PAPER DISPENS | 174D-X3QG-DXL1  | 16.62         |
|                 | 11250            | BENCHMARK COMMUNITY BANK  | FLOWERS              | 3197 ADMIN 0423 | 23.99         |
|                 | 11250            | BENCHMARK COMMUNITY BANK  | PVC/PLASTIC/GP SAW   | 3197 ADMIN 0423 | 63.27         |
|                 | 11250            | BENCHMARK COMMUNITY BANK  | KEY COPIES           | 3197 ADMIN 0423 | 35.85         |
|                 | 11250            | BENCHMARK COMMUNITY BANK  | ART WRK HANDING SYST | 3197 ADMIN 0423 | 254.16        |
|                 | 12998            | CWT, INC.                 | TRIPLE SHED MULCH    | 19756           | 475.00        |
|                 | 13369            | DIAMOND SPRINGS WATER INC | 5 GL WATER           | 3062 3563220    | 11.54         |
|                 | 13369            | DIAMOND SPRINGS WATER INC | WATER COOLER RENT    | 3062 3584193    | 8.95          |
|                 | 13369            | DIAMOND SPRINGS WATER INC | WATER COOLER RENT    | 3062 3584194    | 8.95          |
|                 | 13369            | DIAMOND SPRINGS WATER INC | 5 GL WATER           | 3062 3614718    | 19.13         |
|                 | 15560            | FARMVILLE WHSALE ELECTRIC | FLUOR LAMP/250WLAMP  | 762421          | 522.94        |
|                 | 15560            | FARMVILLE WHSALE ELECTRIC | CODING TAPE          | 764236          | 21.15         |
|                 | 19371            | JOE GILES SIGNS INC       | RELCT SIGN AT CRTHSE | 4305            | 550.00        |
|                 | 19371            | JOE GILES SIGNS INC       | BOS CTHSE ENTR LTRS  | 4306            | 2,700.00      |
|                 | 19371            | JOE GILES SIGNS INC       | AG BUILDING SIGN     | 4307            | 1,354.00      |
|                 | 20600            | KEY OFFICE SUPPLY         | FLASH DRIVES         | 415 577028      | 21.98         |
|                 | 21005            | KORMAN SIGNS              | SIGNS, STREET        | 373481          | 184.12        |
|                 | 21005            | KORMAN SIGNS              | (250)MILE PST SIGNS  | 374089          | 2,959.95      |
|                 | 21811            | LOWE'S                    | TREATED LUMBER       | 901135-KSOGVS   | 203.16        |
|                 |                  |                           |                      |                 | ACCOUNT TOTAL |

| MAJOR#<br>ACCT# | VENDOR<br>NUMBER | VENDOR<br>NAME             | INVOICE#       | DESCRIPTION          | AMOUNT       |
|-----------------|------------------|----------------------------|----------------|----------------------|--------------|
|                 | 21811            | LOWE'S                     | 901505-KRORAP  | TREATED WD/SEMIBASE  | 84.46        |
|                 | 21811            | LOWE'S                     | 901705-KTLZCX  | PYRAMID POST         | 56.52        |
|                 | 21811            | LOWE'S                     | 906200-KRHHR   | MAINT SUPPLIES       | 236.93       |
|                 | 21811            | LOWE'S                     | 906883-KSJDDC  | SCRPR/BRUSH/LWN/BAT  | 65.00        |
|                 | 21811            | LOWE'S                     | 914358-KUMINW  | PVC/WEED PREVENTION  | 22.81        |
|                 | 21811            | LOWE'S                     | 973143-KTLZDT  | PEST GLUE TRAPS      | 19.32        |
|                 | 25680            | PRICE SUPPLY CO INC        | 2303-155416    | BOWL RING/BOLT       | 12.80        |
|                 | 29083            | TAYLOR-FORBES EQUIP CO     | IN00560        | OIL/FILE/1GL WOOD B  | 72.83        |
|                 | 31351            | VERNON COMPANY             | 2602327 RI     | (3) 5X8 POLY FLAG    | 396.00       |
|                 | 31351            | VERNON COMPANY             | 2602327 RI     | (3) 4X6 NYLON FLAGS  | 498.75       |
|                 | 31351            | VERNON COMPANY             | 2602327 RI     | 4X6 FLG ART REVISION | 45.00        |
|                 | 31351            | VERNON COMPANY             | 2602327 RI     | SHIPPING             | 29.71        |
|                 | 31351            | VERNON COMPANY             | 2602329 RI     | ACRYLIC 4X4 SIGN     | 907.00       |
|                 | 32926            | WRIGHT AUTO SUPPLY         | 251179         | IND V BELT           | 8.29         |
| 6008            |                  | Vehicle & Powered Equip F  |                | ACCOUNT TOTAL        | 11,890.18 *  |
|                 | 25782            | PRINCE EDWARD CO PBLC SCH  | DIESEL 0123    | B & G DIESEL         | 99.30        |
|                 | 25782            | PRINCE EDWARD CO PBLC SCH  | DIESEL 0223    | B & G DIESEL         | 129.32       |
|                 | 25782            | PRINCE EDWARD CO PBLC SCH  | DIESEL 1222    | B & G DIESEL         | 199.66       |
| 6009            |                  | Vehicle & Powered Equip S  |                | ACCOUNT TOTAL        | 428.28 *     |
|                 | 15721            | FISHER AUTO PARTS, INC.    | 056-320225     | AUTOMOTIVE BATTERY   | 132.95       |
|                 | 32926            | WRIGHT AUTO SUPPLY         | 251591         | WASHER FLD/MTR TNEUP | 15.11        |
| 6011            |                  | Uniforms & Wearing Appare  |                | ACCOUNT TOTAL        | 148.06 *     |
|                 | 27922            | CINTAS CORPORATION #524    | 4150301938     | UNIFORM RENTAL       | 89.23        |
|                 | 27922            | CINTAS CORPORATION #524    | 4150975520     | UNIFORM RENTAL       | 89.49        |
|                 | 27922            | CINTAS CORPORATION #524    | 4151681045     | UNIFORM RENTAL       | 89.49        |
|                 | 27922            | CINTAS CORPORATION #524    | 4152384219     | UNIFORM RENTAL       | 89.49        |
| 043400          |                  | CANNERY                    |                | ACCOUNT TOTAL        | 357.70 *     |
|                 |                  |                            |                | MAJOR TOTAL          | 27,154.97 ** |
| 3161            | 31653            | Professional Services-Can  | 778            | COMM CANNERY CONTRI  | 2,916.67     |
|                 |                  | VIRGINIA FOOD WORKS        |                | ACCOUNT TOTAL        | 2,916.67 *   |
| 5110            | 28640            | Electrical Services        | 44435001 0423  | ELECTRIC CANNERY     | 359.97       |
|                 |                  | SOUTHSIDE ELECTRIC COOP    |                | ACCOUNT TOTAL        | 359.97 *     |
| 5230            | 21319            | Telecommunications         | 310248529 0423 | PHONE CANNERY        | 114.01       |
|                 |                  | BRIGHTSPEED                |                | ACCOUNT TOTAL        | 114.01 *     |
| 053500          |                  | COMPREHENSIVE SERVICES ACT |                | ACCOUNT TOTAL        | 3,390.65 **  |
| 3160            | 11191            | CSA Programs               |                | ACCOUNT TOTAL        | 114.01 *     |
|                 |                  | BEAR CREEK ACADEMY         |                | MAJOR TOTAL          | 3,390.65 **  |
|                 |                  |                            |                | ACCOUNT TOTAL        | 5,400.00     |

| MAJOR#<br>ACCT# | VENDOR<br>NUMBER     | VENDOR<br>NAME                              | INV#            | DESCRIPTION          | AMOUNT       |
|-----------------|----------------------|---------------------------------------------|-----------------|----------------------|--------------|
| 081100          | PLANNING             |                                             |                 |                      |              |
| 3600            | 12929                | CROSSROADS SERVICES BD                      |                 | PROFESSIONAL SERVICE | 367.31       |
|                 | 12929                | CROSSROADS SERVICES BD                      |                 | PROFESSIONAL SERVICE | 367.31       |
|                 | 12929                | CROSSROADS SERVICES BD                      |                 | PROFESSIONAL SERVICE | 367.31       |
|                 | 14939                | FAMILY PRESERVATION SERV                    |                 | PROFESSIONAL SERVICE | 245.00       |
|                 | 14939                | FAMILY PRESERVATION SERV                    |                 | PROFESSIONAL SERVICE | 1,312.50     |
|                 | 14939                | FAMILY PRESERVATION SERV                    |                 | PROFESSIONAL SERVICE | 455.00       |
|                 | 14939                | FAMILY PRESERVATION SERV                    |                 | PROFESSIONAL SERVICE | 87.00        |
|                 | 15965                | FULCRUM COUNSELORS, LLC                     |                 | PROFESSIONAL SERVICE | 825.00       |
|                 | 15965                | FULCRUM COUNSELORS, LLC                     |                 | PROFESSIONAL SERVICE | 870.00       |
|                 | 16672                | GRAFTON SCHOOL INC                          |                 | PROFESSIONAL SERVICE | 8,761.00     |
|                 | 21784                | LIFE PUSH, LLC                              |                 | PROFESSIONAL SERVICE | 560.00       |
|                 | 27578                | SH VARSITY ACQUISITION SUB                  |                 | PROFESSIONAL SERVICE | 5,786.00     |
|                 | 27578                | SH VARSITY ACQUISITION SUB                  |                 | PROFESSIONAL SERVICE | 5,786.00     |
|                 |                      |                                             |                 | ACCOUNT TOTAL        | 31,189.43 *  |
|                 |                      |                                             |                 | MAJOR TOTAL          | 31,189.43 ** |
| 3600            | 15241                | Advertising<br>FARMVILLE HERALD             | 222498 1606393  | PC MEETING AD        | 455.15       |
| 5210            | 11250                | Postal Services<br>BENCHMARK COMMUNITY BANK | 1563 ADMIN 0423 | USPS CHARGES-PLANING | 7.50 *       |
| 5230            | 31339                | Telecommunications<br>VERIZON WIRELESS      | 242374982 0423  | CELL PHONE           | 7.50 *       |
| 6001            | 11250                | Office Supplies<br>BENCHMARK COMMUNITY BANK | 1563 ADMIN 0423 | ADOBE SUBSCRIPTION   | 19.99        |
|                 | 11902                | BUSINESS DATA OF VA, INC.                   | 01-2289         | NORTON RENWL-PLANING | 44.99        |
|                 | 19946                | JUDY ELLINGTON DESIGN                       | 8317            | BUSINESS CARDS-LOVE  | 62.45        |
|                 |                      |                                             |                 | ACCOUNT TOTAL        | 127.43 *     |
|                 |                      |                                             |                 | MAJOR TOTAL          | 670.66 **    |
| 081500          | ECONOMIC DEVELOPMENT |                                             |                 |                      |              |
| 3600            | 21756                | Advertising<br>LETTERPRESS COMMUNICATIONS   | 2621            | ECON DEV MARCH HRS   | 1,125.00     |
|                 | 21756                | LETTERPRESS COMMUNICATIONS                  | 2621            | BANNER DSGN/DEVLPMNT | 2,500.00     |
|                 | 21756                | LETTERPRESS COMMUNICATIONS                  | 2621            | BANNER PRINTING (2)  | 1,033.43     |
|                 |                      |                                             |                 | ACCOUNT TOTAL        | 4,658.43 *   |
| 5210            | 30669                | Postal Services<br>U S POSTAL SERVICE       | BOX RENT 0423   | PO BOX RENT 625      | 234.00       |
| 5230            | 31339                | Telecommunications<br>VERIZON WIRELESS      | 242374982 0423  | CELL PHONE           | 234.00 *     |
| 6001            | 11250                | Office Supplies<br>BENCHMARK COMMUNITY BANK | 1563 ADMIN 0423 | ADOBE SUBSCRIPTION   | 40.29        |
|                 |                      |                                             |                 | ACCOUNT TOTAL        | 40.29 *      |
|                 |                      |                                             |                 | MAJOR TOTAL          | 19.99        |

| MAJOR#<br>ACCT# | VENDOR<br>NUMBER | VENDOR<br>NAME             | INVT#           | DESCRIPTION          | ACCOUNT TOTAL<br>MAJOR TOTAL | AMOUNT       |
|-----------------|------------------|----------------------------|-----------------|----------------------|------------------------------|--------------|
| 081600          | 11902            | BUSINESS DATA OF VA, INC.  | 01-2294         | NORTON RENEL-ECON DV | 44.99                        | 44.99 *      |
| 3600            | 21756            | Advertising                | 2621            | TOURISM MARCH 23 HRS | 64.98                        | 64.98 *      |
| 3700            | 21756            | Letterpress Communications | 2621            | TRSM MELTWATER APR23 | 4,997.70                     | 4,997.70 **  |
| 5130            | 29332            | Water & Sewer              | VISTR CTR 0323  | WATER & SEWER        | 2,250.00                     | 2,250.00 *   |
| 5210            | 11250            | Postal Services            | 1563 ADMIN 0423 | UPS CHARGES          | 150.00                       | 150.00 *     |
| 5230            | 20904            | Telecommunications         | 1563 ADMIN 0423 | UPS CHARGES          | 150.00                       | 150.00 *     |
| 5893            | 21756            | VTC DMO Marketing Grant    | 2304-0017389    | VISITORS CENTER      | 53.04                        | 53.04 *      |
| 6001            | 20600            | Office Supplies            | 1               | RECEIPT BOOK         | 19.02                        | 19.02        |
| 082300          | 17925            | FLOOD & EROSION CONTROL    | 2621            | FACEBK ADS FEB 23    | 33.48                        | 33.48        |
| 5470            | 17925            | Stormwater Review Fees     | 2626            | FACEBK ADS MARCH     | 17.09                        | 17.09        |
| 083500          | COOPERATIVE      | EXTENSION OFFICE           |                 | WONDERFUL WELNS WKEN | 69.59                        | 69.59 *      |
| 3199            | 29913            | Purchase of Service - Oth  |                 |                      | 111.85                       | 111.85 *     |
| 5230            | 21319            | Telecommunications         |                 |                      | 111.85                       | 111.85 *     |
|                 |                  | TELECOMMUNICATIONS         |                 |                      | 625.00                       | 625.00       |
|                 |                  | BRIGHTSPEED                |                 |                      | 782.56                       | 782.56       |
|                 |                  |                            |                 |                      | 6,875.00                     | 6,875.00 *   |
|                 |                  |                            |                 |                      | 8,282.56                     | 8,282.56 *   |
|                 |                  |                            |                 |                      | 14.46                        | 14.46 *      |
|                 |                  |                            |                 |                      | 14.46                        | 14.46 *      |
|                 |                  |                            |                 |                      | 10,931.50                    | 10,931.50 ** |
|                 |                  |                            |                 |                      | 775.00                       | 775.00 *     |
|                 |                  |                            |                 |                      | 775.00                       | 775.00 *     |
|                 |                  |                            |                 |                      | 775.00                       | 775.00 **    |
|                 |                  |                            |                 |                      | 11,790.15                    | 11,790.15 *  |
|                 |                  |                            |                 |                      | 11,790.15                    | 11,790.15 *  |
|                 |                  |                            |                 |                      | 149.70                       | 149.70 *     |
|                 |                  |                            |                 |                      | 149.70                       | 149.70 *     |
|                 |                  |                            |                 |                      | 11,939.85                    | 11,939.85 ** |



| MAJOR#<br>ACCT#<br>091000 | VENDOR<br>NUMBER<br>GENERAL | VENDOR<br>NAME<br>EXPENSE | INV#            | DESCRIPTION          | AMOUNT       |
|---------------------------|-----------------------------|---------------------------|-----------------|----------------------|--------------|
| 5230                      |                             | Internal Telecom Account  |                 |                      |              |
|                           | 20904                       | KINEX NETWORKING SOLUTION | 2303-0016211DUP | GEN DIST COURT       | 70.30        |
|                           | 20904                       | KINEX NETWORKING SOLUTION | 2303-0016212DUP | PIEDMNT HEALTH DIST  | 85.25        |
|                           | 20904                       | KINEX NETWORKING SOLUTION | 2303-0016213DUP | PLANNING/BUILDING    | 17.45        |
|                           | 20904                       | KINEX NETWORKING SOLUTION | 2303-0016214DUP | COMM OF REVENUE      | 71.80        |
|                           | 20904                       | KINEX NETWORKING SOLUTION | 2303-0016215DUP | TREASURER            | 70.85        |
|                           | 20904                       | KINEX NETWORKING SOLUTION | 2303-0016216DUP | JUV PROB/PAROLE      | 55.85        |
|                           | 20904                       | KINEX NETWORKING SOLUTION | 2303-0016217DUP | MAGISTRATE           | 55.35        |
|                           | 20904                       | KINEX NETWORKING SOLUTION | 2304-0017390    | COUNTY ADMIN         | 140.30       |
|                           | 20904                       | KINEX NETWORKING SOLUTION | 2304-0017391    | HEALTH DEPT          | 88.75        |
|                           | 20904                       | KINEX NETWORKING SOLUTION | 2304-0017392    | COMMWEALTH ATTY      | 71.80        |
|                           | 20904                       | KINEX NETWORKING SOLUTION | 2304-0017393    | COMM OF REVENUE      | 71.80        |
|                           | 20904                       | KINEX NETWORKING SOLUTION | 2304-0017394    | JUV PROBATION/PAROLE | 55.85        |
|                           | 20904                       | KINEX NETWORKING SOLUTION | 2304-0017395    | CIRCUIT CLERK        | 116.20       |
|                           | 20904                       | KINEX NETWORKING SOLUTION | 2304-0017396    | PEC SHERIFF          | 102.20       |
|                           | 20904                       | KINEX NETWORKING SOLUTION | 2304-0017397    | PLANNING/BUILDING    | 17.45        |
|                           | 20904                       | KINEX NETWORKING SOLUTION | 2304-0017398    | JUV & DOMESTIC RELTN | 55.35        |
|                           | 20904                       | KINEX NETWORKING SOLUTION | 2304-0017399    | TREASURER            | 70.85        |
|                           | 20904                       | KINEX NETWORKING SOLUTION | 2304-0017400    | MAGISTRATE           | 55.35        |
|                           | 20904                       | KINEX NETWORKING SOLUTION | 2304-0017401    | VOTER REGISTRAR      | 55.35        |
|                           | 20904                       | KINEX NETWORKING SOLUTION | 2304-0017402    | GENERAL DIST COURT   | 70.30        |
|                           | 20904                       | KINEX NETWORKING SOLUTION | 2304-0017403    | VICTIM WITNESS       | 15.45        |
|                           | 20904                       | KINEX NETWORKING SOLUTION | 2304-0017404    | PIEDMONT HEALTH DIST | 85.25        |
|                           | 20904                       | KINEX NETWORKING SOLUTION | 2304-0017405    | CIRCUIT COURT        | 55.35        |
|                           | 23933                       | SEGRA                     | 165866886 0323  | INTERNET             | 1,148.25     |
|                           |                             |                           |                 | ACCOUNT TOTAL        | 2,702.70 *   |
| 5803                      |                             | Internal Fuel Account     |                 |                      |              |
|                           | 25247                       | PARKER OIL COMPANY INC    | 299915 14080G 7 | GAS                  | 2,888.74     |
|                           | 25247                       | PARKER OIL COMPANY INC    | 307016 14080G 7 | GAS                  | 2,874.03     |
|                           | 25247                       | PARKER OIL COMPANY INC    | 314919 14080G 7 | GAS                  | 1,762.79     |
|                           | 25247                       | PARKER OIL COMPANY INC    | 321919 14080G 7 | GAS                  | 1,592.27     |
|                           | 25247                       | PARKER OIL COMPANY INC    | 327405 14080G 7 | GAS                  | 3,151.87     |
|                           | 25247                       | PARKER OIL COMPANY INC    | 334530 14080G 7 | GAS                  | 3,527.18     |
|                           | 25247                       | PARKER OIL COMPANY INC    | 341190 14080G 7 | GAS                  | 3,939.67     |
|                           | 25247                       | PARKER OIL COMPANY INC    | 348916 14080G 7 | GAS                  | 2,555.78     |
|                           | 25247                       | PARKER OIL COMPANY INC    | 355702 14080G 7 | GAS                  | 3,539.72     |
|                           | 25247                       | PARKER OIL COMPANY INC    | 362436 14080G 7 | GAS                  | 3,691.71     |
|                           | 25247                       | PARKER OIL COMPANY INC    | 369423 14080G 7 | GAS                  | 3,031.41     |
|                           | 25247                       | PARKER OIL COMPANY INC    | 376387 14080G 7 | GAS                  | 3,503.84     |
|                           |                             |                           |                 | ACCOUNT TOTAL        | 36,059.01 *  |
| 5807                      |                             | Contingency               |                 |                      |              |
|                           | 11250                       | BENCHMARK COMMUNITY BANK  | 1563 ADMIN 0423 | FLOWERS-STANLEY      | 246.92       |
|                           | 11250                       | BENCHMARK COMMUNITY BANK  | 1563 ADMIN 0423 | MACADO'S EMP OF MNTH | 120.00       |
|                           | 11250                       | BENCHMARK COMMUNITY BANK  | 1563 ADMIN 0423 | FLOWER-S LEE         | 85.00        |
|                           |                             |                           |                 | ACCOUNT TOTAL        | 451.92 *     |
| 5811                      |                             | Flores Admin Fee          |                 |                      |              |
|                           | 15837                       | FLORES & ASSOCIATES, LLC  | 425808          | APRIL 2023           | 100.00       |
|                           |                             |                           |                 | ACCOUNT TOTAL        | 100.00 *     |
|                           |                             |                           |                 | MAJOR TOTAL          | 39,313.63 ** |

| MAJOR#<br>ACCT# | VENDOR<br>NUMBER<br>NAME       | INVOICE#        | DESCRIPTION          | AMOUNT        |
|-----------------|--------------------------------|-----------------|----------------------|---------------|
| 094000          | CAPITAL PROJECTS               |                 |                      |               |
| 0007            | BUSINESS PARK ROAD DEVELO      |                 |                      |               |
|                 | 19931 J.R. CASKEY, INC.        | APPLICATION 2   | IND ACCESS RD PMT 2  | 214,724.90    |
|                 | 29280 TIMMONS GROUP            | 311440 46958    | PEC BUS PRK ACC RD   | 2,000.00      |
|                 | 29280 TIMMONS GROUP            | 311757 49081    | PEBP ACC RD REDSN    | 102.00        |
|                 | 29280 TIMMONS GROUP            | 311760 56908    | PEBP ACC RD CONST SV | 4,462.50      |
|                 |                                |                 | ACCOUNT TOTAL        | 221,289.40 *  |
| 0010            | Compactor Site Improvemen      |                 |                      |               |
|                 | 11250 BENCHMARK COMMUNITY BANK | 1563 ADMIN 0423 | CPDES CONS PERMIT    | 771.12        |
|                 | 21811 LOWE'S                   | 901484-KTGVEJ   | RICE TEMP SITE       | 61.22         |
|                 | 21811 LOWE'S                   | 901569-KSDUTL   | RICE TEMP SITE       | 170.44        |
|                 | 21811 LOWE'S                   | 906090-KSOGUF   | RICE TEMP SITE       | 77.72         |
|                 | 21811 LOWE'S                   | 914747-KSSRWP   | RICE TEMP SITE       | 18.92         |
|                 | 31846 DOMINION ENERGY VIRGINIA | 0335175873 0323 | ELECT TEMP RICE SITE | 2,353.48      |
|                 |                                |                 | ACCOUNT TOTAL        | 3,452.90 *    |
| 0043            | General Properties             |                 |                      |               |
|                 | 18910 J W SQUIRE CO., INC.     | 12332           | SECTION 2 FLOOR      | 19,801.00     |
|                 | 18910 J W SQUIRE CO., INC.     | 12333           | AREA 1 FLOOR         | 16,159.00     |
|                 |                                |                 | ACCOUNT TOTAL        | 35,960.00 *   |
|                 |                                |                 | MAJOR TOTAL          | 260,702.30 ** |
|                 |                                |                 | FUND TOTAL           | 768,602.59    |

PUBLIC/PRIVATE EDUCATION ACT FUND

| MAJOR# | ACCT#  | VENDOR NUMBER | VENDOR NAME                                          | INV#    | DESCRIPTION          | ACCOUNT TOTAL | AMOUNT      |
|--------|--------|---------------|------------------------------------------------------|---------|----------------------|---------------|-------------|
| 3150   | 010000 | 25213         | Legal Services<br>PANDAK & TAVES, PLLC               | 671     | SRR WATER PRJCT PPEA | 2,696.70      | 2,696.70 *  |
| 3160   | 010000 | 25327         | Professional Service-Engi<br>PENNONI ASSOCIATES INC. | 1165224 | COPE21001 PPEA ENG   | 2,288.50      | 2,288.50 *  |
|        |        |               |                                                      |         |                      | 4,985.20      | 4,985.20 ** |
|        |        |               |                                                      |         |                      | FUND TOTAL    | 4,985.20    |

| MAJOR#<br>ACCT#<br>032301 | VENDOR<br>NUMBER<br>EMS | VENDOR<br>NAME            | INV#         | DESCRIPTION          | AMOUNT       |
|---------------------------|-------------------------|---------------------------|--------------|----------------------|--------------|
| 7005                      | 25880                   | PRINCE EDWARD VOL RESCUE  | 202207001750 | REIMB HLTH INS 7/22  | 5,784.05     |
|                           | 25880                   | PRINCE EDWARD VOL RESCUE  | 202207001751 | REIMB HLTH INS 8/22  | 5,396.90     |
|                           | 25880                   | PRINCE EDWARD VOL RESCUE  | 202208601103 | REIMB HLTH INS 9/22  | 5,396.90     |
|                           | 25880                   | PRINCE EDWARD VOL RESCUE  | 202209601224 | REIMB HLTH INS 10/22 | 6,975.77     |
|                           | 25880                   | PRINCE EDWARD VOL RESCUE  | 202210601334 | REIMB HLTH INS 11/22 | 5,923.19     |
|                           | 25880                   | PRINCE EDWARD VOL RESCUE  | 202211601435 | REIMB HLTH INS 12/22 | 5,923.19     |
|                           | 25880                   | PRINCE EDWARD VOL RESCUE  | 202212601633 | REIMB HLTH INS 1/23  | 4,026.83     |
|                           | 25880                   | PRINCE EDWARD VOL RESCUE  | 202301601811 | REIMB HLTH INS 2/23  | 5,291.07     |
|                           | 25880                   | PRINCE EDWARD VOL RESCUE  | 202302601980 | REIMB HLTH INS 3/23  | 5,291.07     |
|                           | 25880                   | PRINCE EDWARD VOL RESCUE  | 202303602054 | REIMB HLTH INS 4/23  | 5,291.07     |
| 7008                      |                         | Meherrin EMS              |              |                      | 55,300.04 *  |
|                           | 11491                   | ARC3 GASES                | 9581048      | CYLINDER RENTAL      | 43.40        |
|                           | 11491                   | ARC3 GASES                | 9644687      | OXYGEN               | 149.92       |
|                           | 11491                   | ARC3 GASES                | 9647534      | OXYGEN               | 131.10       |
|                           | 11491                   | ARC3 GASES                | 9662670      | CYLINDER RENTAL      | 40.32        |
|                           | 14734                   | EMERGENCY MEDICAL PRODUCT | 2531589      | EMS SUPPLIES         | 474.42       |
|                           | 14734                   | EMERGENCY MEDICAL PRODUCT | 2535927      | ONDANSETRON 4MG      | 139.99       |
| 7010                      |                         | Hampden Sydney EMS        |              |                      | 979.15 *     |
|                           | 10174                   | AIRGAS USA, LLC           | 9996339625   | CYLINDER LEASE RENWL | 620.00       |
|                           | 14734                   | EMERGENCY MEDICAL PRODUCT | 2539931      | EMS SUPPLIES         | 228.31       |
|                           | 14734                   | EMERGENCY MEDICAL PRODUCT | 2542011      | EMS SUPPLIES         | 916.11       |
|                           |                         |                           |              | ACCOUNT TOTAL        | 1,764.42 *   |
|                           |                         |                           |              | MAJOR TOTAL          | 58,043.61 ** |
|                           |                         |                           |              | FUND TOTAL           | 58,043.61    |

| MAJOR#<br>ACCT# | VENDOR<br>NUMBER | VENDOR<br>NAME                                      | INV#          | DESCRIPTION                      | ACCOUNT TOTAL<br>MAJOR TOTAL | AMOUNT                  |
|-----------------|------------------|-----------------------------------------------------|---------------|----------------------------------|------------------------------|-------------------------|
| 012110          | 13779            | Professional Services-Eng<br>DRAPER ADEN ASSOCIATES | 102290 506094 | PLN REV MANOR GRAVIT             | 1,800.00<br>1,800.00 *       | 1,800.00<br>1,800.00 ** |
| 043200          |                  | GENERAL PROPERTIES                                  |               |                                  |                              |                         |
| 5130            | 29332            | Water Service<br>TOWN OF FARMVILLE                  |               | WATER TANK 0323<br>WATER & SEWER | 98.95<br>98.95 *             | 98.95<br>98.95 **       |
|                 |                  |                                                     |               | FUND TOTAL                       |                              | 1,898.95                |

| MAJOR#<br>ACCT#<br>043200 | VENDOR<br>NUMBER<br>GENERAL PROPERTIES | VENDOR<br>NAME                                  | INV#       | DESCRIPTION   | AMOUNT   |
|---------------------------|----------------------------------------|-------------------------------------------------|------------|---------------|----------|
| 5110                      | 31846                                  | Electrical Services<br>DOMINION ENERGY VIRGINIA | 4148700281 | SEWER PUMP    | 55.60    |
|                           |                                        |                                                 |            | ACCOUNT TOTAL | 55.60 *  |
|                           |                                        |                                                 |            | MAJOR TOTAL   | 55.60 ** |
|                           |                                        |                                                 |            | FUND TOTAL    | 55.60    |

| MAJOR#<br>ACCT#<br>042300 | VENDOR<br>NUMBER<br>COLLECTIONS | VENDOR<br>NAME                                         | INV#            | DESCRIPTION          | AMOUNT     |
|---------------------------|---------------------------------|--------------------------------------------------------|-----------------|----------------------|------------|
| 3311                      | 14300                           | Repairs & Maint-Auto & Eq<br>EAST END MOTOR CO INC     | 0225408         | (2) TIRES MNT/BAL    | 1,089.76   |
|                           | 14300                           | EAST END MOTOR CO INC                                  | 0225948         | (2) TIRES            | 1,676.64   |
|                           | 25596                           | POWELL'S IDEALEASE, LLC                                | 683323          | BREATHER             | 754.21     |
|                           | 28091                           | SCHMIDT'S REPAIR SERVICE                               | 1677            | RPR INTL ROLL OFF    | 1,406.00   |
|                           |                                 |                                                        |                 | ACCOUNT TOTAL        | 4,926.61 * |
| 3840                      | 10254                           | Contract Landfill - POS<br>REPUBLIC SERVICES #974      | 3 0974 0004167  | TRASH COLLECTION     | 494.41     |
|                           | 10254                           | REPUBLIC SERVICES #974                                 | 3 0974 0004168  | TRASH COLLECTION     | 282.69     |
|                           | 10254                           | REPUBLIC SERVICES #974                                 | 3 0974 0004169  | TRASH COLLECTION     | 277.58     |
|                           |                                 |                                                        |                 | ACCOUNT TOTAL        | 1,054.68 * |
| 3841                      | 28866                           | Purchase of Service - Rec<br>STEPS, INC                | MARCH 2023      | RECYCLING            | 3,304.12   |
|                           | 29029                           | SYNERGY RECYCLING LLC                                  | 2300045         | RECYCLE ELECTRONICS  | 3,381.80   |
|                           | 29029                           | SYNERGY RECYCLING LLC                                  | 2300125         | RECYCLING ELECTRONIC | 2,718.50   |
|                           |                                 |                                                        |                 | ACCOUNT TOTAL        | 9,404.42 * |
| 5110                      | 28640                           | Electrical Services<br>SOUTHSIDE ELECTRIC COOP         | 114379001 0423  | DARLINGTON HGHTS     | 68.29      |
|                           | 28640                           | SOUTHSIDE ELECTRIC COOP                                | 114379003 0323  | RECYCLING CENTER     | 102.12     |
|                           | 31846                           | DOMINION ENERGY VIRGINIA                               | 0599507431-0323 | CLOSING BILL RICE ST | 42.86      |
|                           |                                 |                                                        |                 | ACCOUNT TOTAL        | 213.27 *   |
| 5230                      | 21319                           | Telecommunications<br>BRIGHTSPEED                      | 309480181 0323  | GREEN BAY CONV SITE  | 80.35      |
|                           | 21319                           | BRIGHTSPEED                                            | 309553498 0323  | RICE CONV SITE       | 62.24      |
|                           | 21319                           | BRIGHTSPEED                                            | 309615846 0323  | TUGGLE CONV SITE     | 74.94      |
|                           | 21319                           | BRIGHTSPEED                                            | 309714661 0423  | PROSPECT CONV SITE   | 80.00      |
|                           | 21319                           | BRIGHTSPEED                                            | 310039285 0423  | WORSHAM CONV SITE    | 56.63      |
|                           | 31339                           | VERIZON WIRELESS                                       | 242374982 0423  | CELL PHONE           | 23.21      |
|                           |                                 |                                                        |                 | ACCOUNT TOTAL        | 377.37 *   |
| 5440                      | 28869                           | Portable Toilet Rental<br>STIFF O O INC                | 10392           | MONTHLY SERVICE      | 877.50     |
|                           |                                 |                                                        |                 | ACCOUNT TOTAL        | 877.50 *   |
| 6008                      | 25782                           | Vehicle & Powered Equip F<br>PRINCE EDWARD CO PBLC SCH | DIESEL 0123     | COLLECTIONS DIESEL   | 2,493.05   |
|                           | 25782                           | PRINCE EDWARD CO PBLC SCH                              | DIESEL 0223     | COLLECTIONS DIESEL   | 1,425.41   |
|                           | 25782                           | PRINCE EDWARD CO PBLC SCH                              | DIESEL 1222     | COLLECTIONS DIESEL   | 1,617.92   |
|                           |                                 |                                                        |                 | ACCOUNT TOTAL        | 5,536.38 * |
| 6009                      | 21297                           | Vehicle & Powered Equip S<br>LANGLOIS PAUL             | REIMB 0323      | LOAD BINDERS         | 68.98      |
|                           | 32926                           | WRIGHT AUTO SUPPLY                                     | 250071          | SHOP TWLS/CPLNG/TAPE | 32.79      |
|                           |                                 |                                                        |                 | ACCOUNT TOTAL        | 101.77 *   |
| 6030                      | 10259                           | Non-Capital Equipment<br>AMAZON CAPITAL SERVICES       | 1TQ6-XTNT-9R9D  | 6PC HAMMER SET       | 82.49      |
|                           | 10259                           | AMAZON CAPITAL SERVICES                                | 1TQ6-XTNT-9R9D  | 24 GALLON SUMP       | 186.54     |
|                           | 10259                           | AMAZON CAPITAL SERVICES                                | 1TQ6-XTNT-9R9D  | 24GALLON SUMP        | 186.54     |
|                           | 10259                           | AMAZON CAPITAL SERVICES                                | 1TQ6-XTNT-9R9D  | 4PC HVY DTY PRY BAR  | 57.98      |
|                           | 10259                           | AMAZON CAPITAL SERVICES                                | 1TQ6-XTNT-9R9D  | 6PC LOCKING PLIERS   | 35.49      |

| MAJOR#<br>ACCT# | VENDOR<br>NUMBER                 | VENDOR<br>NAME | INV#           | DESCRIPTION          | AMOUNT       |
|-----------------|----------------------------------|----------------|----------------|----------------------|--------------|
| 042400          | LANDFILL OPERATIONS              |                |                |                      |              |
| 3160            | Professional Services            |                |                |                      |              |
|                 | 21105 LABELLA ASSOCIATES, D.P.C. |                | 192487 2223133 | PE 23 ANNL ENVIR SVC | 29,346.96 *  |
| 3310            | Repairs/Maintenance              |                |                |                      |              |
|                 | 12282 CAVALIER HOSE & FITTINGS   |                | 54519          | ADAPTER WTR TRUCK    | 10.45        |
| 3311            | Equipment Repairs & Maint        |                |                |                      |              |
|                 | 11491 ARC3 GASES                 |                | 9735961        | TILLMAN GLOVES       | 100.44       |
|                 | 11491 ARC3 GASES                 |                | 9750222        | CYLINDER RENTAL      | 33.48        |
|                 | 12220 CARTER MACHINERY CO INC    |                | 1335597        | MAINT/INSP 826H      | 1,744.69     |
|                 | 12220 CARTER MACHINERY CO INC    |                | 4387664        | FILTERS 826H         | 253.16       |
|                 | 12220 CARTER MACHINERY CO INC    |                | 4406299        | CLMP/VLIVE/TEE 963B  | 1,568.51     |
|                 | 13369 DIAMOND SPRINGS WATER INC  |                | 3062 3584192   | WATER COOLER RENT    | 8.95         |
|                 | 13369 DIAMOND SPRINGS WATER INC  |                | 3062 3614746   | 5 GL WATER           | 26.72        |
|                 | 19221 JAMES RIVER EQUIPMENT      |                | P96754         | OIL FILTER           | 39.76        |
|                 | 21297 LANGLOIS PAUL              |                | REIMB 0423     | (2) THERMAL BAKE     | 520.00       |
|                 | 21797 LLEWELLYN METAL WORKS INC  |                | 10006          | WATER TANK REPAIR MT | 260.45       |
|                 | 21797 LLEWELLYN METAL WORKS INC  |                | 10013          | BOLTS/MATERIAL       | 142.40       |
|                 | 21797 LLEWELLYN METAL WORKS INC  |                | 10055          | BEARING ELECT PUMP   | 65.95        |
| 5230            | Telecommunications               |                |                |                      | 4,764.51 *   |
|                 | 21319 BRIGHTSPEED                |                | 309326764 0323 | LANDFILL             | 121.85       |
|                 | 31339 VERIZON WIRELESS           |                | 242374982 0423 | CELL PHONE           | 80.32        |
| 6008            | Fuel                             |                |                |                      | 202.17 *     |
|                 | 14700 ELLINGTON ENERGY SERVICE   |                | 478            | DIESEL               | 308.00       |
|                 | 14700 ELLINGTON ENERGY SERVICE   |                | 5123           | DIESEL               | 236.82       |
|                 | 14700 ELLINGTON ENERGY SERVICE   |                | 5264           | DIESEL               | 237.00       |
|                 | 14700 ELLINGTON ENERGY SERVICE   |                | 5520 0423      | DIESEL               | 261.00       |
|                 | 14700 ELLINGTON ENERGY SERVICE   |                | 6004           | DIESEL               | 278.40       |
|                 | 14700 ELLINGTON ENERGY SERVICE   |                | 6020           | DIESEL               | 220.00       |
|                 | 14700 ELLINGTON ENERGY SERVICE   |                | 9155           | DIESEL               | 276.00       |
| 6009            | Vehicle & Powered Equip S        |                |                |                      | 1,817.22 *   |
|                 | 10616 APPLE VALLEY SCALE CO      |                | 97034          | MAINT/INSP SCALE     | 2,987.00 *   |
| 6011            | Uniforms & Wearing Appare        |                |                |                      |              |
|                 | 27922 CINTAS CORPORATION #524    |                | 4150301938     | UNIFORM RENTAL       | 66.97        |
|                 | 27922 CINTAS CORPORATION #524    |                | 4150975520     | UNIFORM RENTAL       | 66.97        |
|                 | 27922 CINTAS CORPORATION #524    |                | 4151681045     | UNIFORM RENTAL       | 66.97        |
|                 | ACCOUNT TOTAL                    |                |                |                      | 805.91 *     |
|                 | MAJOR TOTAL                      |                |                |                      | 23,297.91 ** |
|                 | ACCOUNT TOTAL                    |                |                |                      | 29,346.96 *  |
|                 | ACCOUNT TOTAL                    |                |                |                      | 10.45        |
|                 | ACCOUNT TOTAL                    |                |                |                      | 10.45 *      |
|                 | ACCOUNT TOTAL                    |                |                |                      | 100.44       |
|                 | ACCOUNT TOTAL                    |                |                |                      | 33.48        |
|                 | ACCOUNT TOTAL                    |                |                |                      | 1,744.69     |
|                 | ACCOUNT TOTAL                    |                |                |                      | 253.16       |
|                 | ACCOUNT TOTAL                    |                |                |                      | 1,568.51     |
|                 | ACCOUNT TOTAL                    |                |                |                      | 8.95         |
|                 | ACCOUNT TOTAL                    |                |                |                      | 26.72        |
|                 | ACCOUNT TOTAL                    |                |                |                      | 39.76        |
|                 | ACCOUNT TOTAL                    |                |                |                      | 520.00       |
|                 | ACCOUNT TOTAL                    |                |                |                      | 260.45       |
|                 | ACCOUNT TOTAL                    |                |                |                      | 142.40       |
|                 | ACCOUNT TOTAL                    |                |                |                      | 65.95        |
|                 | ACCOUNT TOTAL                    |                |                |                      | 4,764.51 *   |
|                 | ACCOUNT TOTAL                    |                |                |                      | 121.85       |
|                 | ACCOUNT TOTAL                    |                |                |                      | 80.32        |
|                 | ACCOUNT TOTAL                    |                |                |                      | 202.17 *     |
|                 | ACCOUNT TOTAL                    |                |                |                      | 308.00       |
|                 | ACCOUNT TOTAL                    |                |                |                      | 236.82       |
|                 | ACCOUNT TOTAL                    |                |                |                      | 237.00       |
|                 | ACCOUNT TOTAL                    |                |                |                      | 261.00       |
|                 | ACCOUNT TOTAL                    |                |                |                      | 278.40       |
|                 | ACCOUNT TOTAL                    |                |                |                      | 220.00       |
|                 | ACCOUNT TOTAL                    |                |                |                      | 276.00       |
|                 | ACCOUNT TOTAL                    |                |                |                      | 1,817.22 *   |
|                 | ACCOUNT TOTAL                    |                |                |                      | 2,987.00 *   |
|                 | ACCOUNT TOTAL                    |                |                |                      | 2,987.00 *   |
|                 | ACCOUNT TOTAL                    |                |                |                      | 66.97        |
|                 | ACCOUNT TOTAL                    |                |                |                      | 66.97        |
|                 | ACCOUNT TOTAL                    |                |                |                      | 66.97        |



AP375H  
5/01/2023  
FUND # - 520

PRINCE EDWARD  
LISTING OF INVOICES FOR 4/01/2023 -- 4/28/2023

AFTER CHECKS  
PAGE 25

| MAJOR# | ACCT# | VENDOR NUMBER | VENDOR NAME             | INV#       | DESCRIPTION    | AMOUNT       |
|--------|-------|---------------|-------------------------|------------|----------------|--------------|
|        |       | 27922         | CINTAS CORPORATION #524 | 4152384219 | UNIFORM RENTAL | 94.13        |
|        |       |               |                         |            |                | 295.04 *     |
|        |       |               |                         |            |                | 39,423.35 ** |
|        |       |               |                         |            | ACCOUNT TOTAL  |              |
|        |       |               |                         |            | MAJOR TOTAL    |              |
|        |       |               |                         |            | FUND TOTAL     | 62,721.26    |

| MAJOR#<br>ACCT# | VENDOR<br>NUMBER<br>NAME          | INVOICE#        | DESCRIPTION           | ACCOUNT TOTAL | AMOUNT      |
|-----------------|-----------------------------------|-----------------|-----------------------|---------------|-------------|
| 021400          | PIEDMONT COURT SERVICES           |                 |                       |               |             |
| 5420            | 28724 SRP CORPORATION LLC         | RENT 0423       | APRIL RENT            | 2,750.00      | 2,750.00 *  |
| 5510            | Travel - Mileage                  |                 |                       |               |             |
|                 | 12595 COLE, BRITNEY               | MILEAGE 0323    | MILEAGE REIMBURSEMENT | 249.95        | 249.95      |
|                 | 22398 MIKIONIS BROOKE             | MILEAGE 0323    | MILEAGE REIMBURSEMENT | 68.12         | 68.12       |
|                 | 22496 MITCHELL, TJYSHAWN          | MILEAGE 0323    | MILEAGE REIMBURSEMENT | 182.09        | 182.09      |
|                 | 27170 REESE-THOMAS A ROCQUELLE    | MILEAGE 0323    | MILEAGE REIMBURSEMENT | 39.30         | 39.30       |
|                 | 28833 STATON REBECCA              | MILEAGE 0323    | MILEAGE REIMBURSEMENT | 84.82         | 84.82       |
|                 | 31091 VITALE MATT                 | MILEAGE 0323    | MILEAGE REIMBURSEMENT | 188.64        | 188.64      |
|                 |                                   |                 | ACCOUNT TOTAL         | 812.92        | 812.92 *    |
|                 |                                   |                 | MAJOR TOTAL           | 3,562.92      | 3,562.92 ** |
| 097001          | PCS SUPERVISION FEES EXPENDITURES |                 |                       |               |             |
| 3199            | PCS - Purchase of Service         |                 |                       |               |             |
|                 | 27159 REDWOOD TOXICOLOGY LAB      | 794112          | 6 PANEL TEST STRIPS   | 1,053.30      | 1,053.30    |
|                 | 27159 REDWOOD TOXICOLOGY LAB      | 795064          | ICUP 6 DRUG TESTS     | 505.53        | 505.53      |
|                 | 27159 REDWOOD TOXICOLOGY LAB      | 795091          | ORAL DEVICE DRUG TST  | 177.82        | 177.82      |
|                 | 28095 ALERE TOXICOLOGY SERV INC   | L348591         | LAB CONF PROBATION    | 82.64         | 82.64       |
|                 | 28095 ALERE TOXICOLOGY SERV INC   | L348591         | LAB CONF PRETRIAL     | 20.66         | 20.66       |
|                 |                                   |                 | ACCOUNT TOTAL         | 1,839.95      | 1,839.95 *  |
| 3310            | PCS - Repairs and Mainten         |                 |                       |               |             |
|                 | 12772 COMPUTER PROJECTS OF IL     | 23-04-05ME      | MSNGR MAINT FOR VCIN  | 198.00        | 198.00      |
|                 |                                   |                 | ACCOUNT TOTAL         | 198.00        | 198.00 *    |
| 5110            | PCS - Utilities                   |                 |                       |               |             |
|                 | 31846 DOMINION ENERGY VIRGINIA    | 4324962309 0323 | PCS ELECTRIC          | 97.52         | 97.52       |
|                 | 31846 DOMINION ENERGY VIRGINIA    | 7218131923 0323 | PCS ELECTRIC          | 172.05        | 172.05      |
|                 |                                   |                 | ACCOUNT TOTAL         | 269.57        | 269.57 *    |
| 5230            | PCS - Telecommunications          |                 |                       |               |             |
|                 | 20904 KINEX NETWORKING SOLUTION   | 2304-0017117    | PCS PHONE BILL        | 67.17         | 67.17       |
|                 | 23933 SEGRA                       | 174057257 0323  | TELECOMMUNICATIONS    | 296.82        | 296.82      |
|                 |                                   |                 | ACCOUNT TOTAL         | 363.99        | 363.99 *    |
| 6001            | PCS - Office Supplies             |                 |                       |               |             |
|                 | 20600 KEY OFFICE SUPPLY           | 401 577403      | SMALL NITRILE GLOVES  | 79.10         | 79.10       |
|                 | 20600 KEY OFFICE SUPPLY           | 401 577404      | PRINTER CARTRIDGE     | 60.62         | 60.62       |
|                 | 20600 KEY OFFICE SUPPLY           | 401 577405      | FAX CARTRIDGE         | 154.77        | 154.77      |
|                 | 20600 KEY OFFICE SUPPLY           | 401 577406      | PRINTER CARTRIDGE     | 47.91         | 47.91       |
|                 | 26525 QUILL CORPORATION           | 31827513        | DESK CHAIR            | 129.99        | 129.99      |
|                 | 26525 QUILL CORPORATION           | 31828611        | HAND SOAP/SANITIZER   | 90.32         | 90.32       |
|                 | 26525 QUILL CORPORATION           | 31828851        | CLOROX CLEANER        | 95.84         | 95.84       |
|                 |                                   |                 | ACCOUNT TOTAL         | 658.55        | 658.55 **   |
|                 |                                   |                 | MAJOR TOTAL           | 3,330.06      | 3,330.06 ** |
|                 |                                   |                 | FUND TOTAL            | 6,892.98      | 6,892.98    |
|                 |                                   |                 | TOTAL DUE             | 903,200.19    | 903,200.19  |

Approved at meeting of \_\_\_\_\_ on \_\_\_\_\_, \_\_\_\_\_  
 Signed \_\_\_\_\_ Title \_\_\_\_\_ Date \_\_\_\_\_

\_\_\_\_\_  
Title  
\_\_\_\_\_  
Date

\_\_\_\_\_  
Title  
\_\_\_\_\_  
Date





February 28, 2023

Prince Edward County, Virginia  
Post Office Box 382  
Farmville, VA 23901

[dstanley@co.prince-edward.va.us](mailto:dstanley@co.prince-edward.va.us)

[spuckett@co.prince-edward.va.us](mailto:spuckett@co.prince-edward.va.us)

[cbaker@co.prince-edward.va.us](mailto:cbaker@co.prince-edward.va.us)

**FOR PROFESSIONAL SERVICES RENDERED:**

**Invoice #1052**

General Legal Representation:

|        |                                                                                                                       |         |
|--------|-----------------------------------------------------------------------------------------------------------------------|---------|
| 2/1/23 | Email and approval of final revised copy of Art Exhibitor Agreement with County and LCVA                              | .25 hr. |
| 2/2/23 | Email re: County Transient Occupancy Tax Meeting with County and Commissioner of Revenue.                             | .25 hr. |
| 2/1/23 | Revisions to Lowe's Drainage Agreement and emails to the involved entities.                                           | .50 hr. |
| 2/1/23 | Email and discussion with Gary Elder, Town of Farmville, concerning Lowe's and sewer easements.                       | .25 hr. |
| 2/1/23 | Email concerning the Tax Map# 019-A-27 tax auction discussion for parcel in Prospect.                                 | .25 hr. |
| 2/2/23 | Email re: Access Road at Industrial Park concerning adjoining property and use for storage of materials               | .25 hr. |
| 2/2/23 | Email concerning Transient Occupancy Tax ordinance for the review prior to the February Board of Supervisors Meeting. | .25 hr. |
| 2/4/23 | Email correspondence with the Town of Farmville concerning the sewer agreement for Lowe's.                            | .25 hr. |
| 2/4/23 | Email with Lowe's attorney concerning three requested                                                                 |         |

revisions to Lowe's Town of Farmville sewer document and storm water drainage agreement. Forward to appropriate parties. Review of 2/7/23 email with revisions. .50hr.

2/6/23 Email discussions with Rob Love concerning Stormwater Management Agreement to be recorded. .25 hr.

2/7/23 Review of final draft ordinance for Transient Occupancy Tax. .50 hr.

2/8/23 Review of closed Session motion in email from Sarah Puckett. .25 hr.

2/8/23 email of revisions to Rob Love for stormwater Management Agreements for Hampden-Sydney College. .25 hr.

2/9/23 Email from Tom Beshere concerning Draft Resolution for additional Opioid Settlement for Prince Edward and Virginia. .25 hr.

2/10/23 Receipt and review of February 14, 2023 Board Meeting Packet. 1.00 hr.

2/14/23 Email from Sarah Puckett concerning review and approval of National Opioid Settlement. .50 hr.

2/14/23 Regularly scheduled meeting of the Prince Edward County Board of Supervisors Meeting. 3.00 hrs.

2/15/23 Email from Doug Stanley and Wayfinding to review their contract or request them to use our standard contract for vendors. .50 hr.

2/16/23 Further discussions regarding comments from Lowe's on the requested revisions to both sewer agreement and waste water drainage agreement. .25 hr.

2/17/23 Final review and approval of edited BMP Maintenance Agreements for Stormwater with Hampden-Sydney College. .25 hr.

2/20/23 Final draft sent to Lowe's counsel regarding sewer easement and stormwater drain agreement for easements. .50 hr.

2/22/23 Response via email from Lowe's counsel and revisions

to stormwater easement and sewer easement. Retrieval  
of plat for Lowe's. Email review and revisions. Sent  
back to Lowe's on 2/23/2023. 1.00 hr.

2/27/23 Email from Tom Beshere, Attorney General's Office  
concerning Settlement Participation Agreement and  
County resolution. Email also. .50 hr.

Total hours = 11.75 hrs. @ \$200.00/hr.

**BALANCE DUE** **\$2,350.00**

**DUE UPON RECEIPT**

Please make check payable to Terri Atkins Wilson, P.C.

**[This page intentionally left blank]**



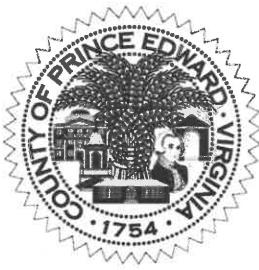

**Board of Supervisors  
Agenda Summary**

**Meeting Date:** May 9, 2023  
**Item #:** 8-d  
**Department:** County Administration  
**Staff Contact:** Cheryl Stimpson  
**Agenda Item:** Salaries

---

**SUMMARY:**

The County Administrator reported that checks have been issued pursuant to the order of the Board of Supervisors as to salaries, etc., the amount of which salaries have been heretofore approved.

**COST:**

**ATTACHMENTS:** None.

**RECOMMENDATION:** None.

**SAMPLE MOTION:**

Motion \_\_\_\_\_  
Second \_\_\_\_\_

Cooper-Jones \_\_\_\_\_  
Emert \_\_\_\_\_

Gilliam \_\_\_\_\_  
Jenkins \_\_\_\_\_  
Jones \_\_\_\_\_

Pride \_\_\_\_\_  
Townsend \_\_\_\_\_  
Watson \_\_\_\_\_

**[This page intentionally left blank]**



**Board of Supervisors  
Agenda Summary**

**Meeting Date:** May 9, 2023  
**Item #:** 9  
**Department:** County Administration  
**Staff Contact:** Sarah Elam Puckett  
**Agenda Item:** Highway Matters

**SUMMARY:**

- 1. VDOT Resident Engineer, Scott D. Frederick, P.E., will not be in attendance at the May meeting. Staff will record any highway matters and share them with VDOT.
- 2. Additionally, as the Board will recall, the FY 24-29 Six-Year Plan will remain unchanged from the current Six-Year Plan. VDOT has indicated that due to funding limitations and escalating costs, no new roads are being added to the Six-Year Plan this year.

The Board will still have to authorize a public hearing on the draft FY 24-29 Six Year Plan and FY 24 Construction Program.

The FY 24-29 plan was not available from VDOT by the time the Board pack was distributed, but will be shared with the Board at the meeting.

**COST:**

**ATTACHMENTS:** None.

**RECOMMENDATION:** None.

**SAMPLE MOTION:** I move the Board authorize a public hearing on the FY 24-29 Six-Year Plan and FY 24 Construction Program for Prince Edward County for the June 13 Board meeting.

|              |                    |               |                |
|--------------|--------------------|---------------|----------------|
| Motion _____ | Cooper-Jones _____ | Gilliam _____ | Pride _____    |
| Second _____ | Emert _____        | Jenkins _____ | Townsend _____ |
|              |                    | Jones _____   | Watson _____   |

**[This page intentionally left blank]**



**Board of Supervisors  
Agenda Summary**

**Meeting Date:** May 9, 2022  
**Item #:** 10  
**Department:** County Administration  
**Staff Contact:** Douglas P. Stanley  
**Agenda Item:** Community Partner Updates

---

**SUMMARY:** The following community partners will join the Board at its May meeting:

**Hampden-Sydney College**

- Larry Stimpert, Ph.D., President of the College
- Ken Copeland, Jr., Vice President for Business Affairs & Finance

**Longwood University**

- Taylor Reveley, IV, President of the University

**Town of Farmville**

- Scott Davis, LP.D., Town Manager

Motion \_\_\_\_\_  
Second \_\_\_\_\_

Cooper-Jones \_\_\_\_\_  
Emert \_\_\_\_\_

Gilliam \_\_\_\_\_  
Jenkins \_\_\_\_\_  
Jones \_\_\_\_\_

Pride \_\_\_\_\_  
Townsend \_\_\_\_\_  
Watson \_\_\_\_\_

**[This page intentionally left blank]**



**Board of Supervisors  
Agenda Summary**

**Meeting Date:** May 9, 2023  
**Item #:** 11-a  
**Department:** Community Development  
**Staff Contact:** Robert Love  
**Agenda Item:** Public Hearing - Special Use Permit - Norvell Signs

**Summary:**

The County has received an application for a Special Use Permit from Norvell Signs on behalf of Prince Edward County Public Schools to replace three existing signs at the Prince Edward County Elementary, Middle, and High Schools with electronic signs on Tax Map Parcels 051-8-2 and 051-A-37 on Zion Hill Road, Farmville, VA. These parcels are zoned A-2, Agricultural Residential and electronic signs require approval of a Special Use Permit.

The public hearing notice was published in the April 26, 2023 and May 3, 2023 editions of the Farmville Herald, Attachment (2). The list of adjoining property owners and the sample letter sent to each can be found in Attachments (3) and (4). Attachment (5) is a copy of the tax map page that depicts the tax map parcel of the parcel and surrounding property. The parcel is outlined in blue.

The Planning Commission held a public hearing on May 20 2023, no one spoke in opposition of the application and the County has received no correspondence opposing the request. The Planning Commission recommended approval with conditions, forwarding the request to the Board of Supervisors for Public Hearing. Attachment (6) is a list of updated Potential Conditions as recommended by the Planning Commission.

**Attachments:**

- 1. Special Use Permit Application
- 2. Notice of Public Hearing
- 3. List of adjoining property owners
- 4. Sample Letter sent to adjoining property owners
- 5. Tax Parcel Map
- 6. Potential Conditions
- 7. Excerpt of the draft minutes of the May 20, 2023 meeting of the Planning Commission.

**Recommendations:**

- 1. Conduct the Public Hearing and render a decision concerning the request for the Special Use.

**Recommended Motions:**

I move that the Board of Supervisors approve the Special Use Permit request by Norvell Signs to replace the existing signs at the Prince Edward County Elementary, Middle, and High Schools with electronic signs with the following conditions: *(list of conditions)*

|              |                    |               |                |
|--------------|--------------------|---------------|----------------|
| Motion _____ | Cooper-Jones _____ | Gilliam _____ | Pride _____    |
| Second _____ | Emert _____        | Jenkins _____ | Townsend _____ |
|              |                    | Jones _____   | Watson _____   |



**Board of Supervisors  
Agenda Summary**

**OR**

I move that the Board of Supervisors deny the Special Use Permit request by Norvell Signs to replace the existing signs at the Prince Edward County Elementary, Middle, and High Schools with electronic signs due to the following: *(list reasons)*

**OR**

I move that the Board of Supervisors table the Special Use Permit request by Norvell Signs to replace the existing signs at the Prince Edward County Elementary, Middle, and High Schools with electronic signs for further discussion at a work session.

Motion \_\_\_\_\_  
Second \_\_\_\_\_

Cooper-Jones \_\_\_\_\_  
Emert \_\_\_\_\_

Gilliam \_\_\_\_\_  
Jenkins \_\_\_\_\_  
Jones \_\_\_\_\_

Pride \_\_\_\_\_  
Townsend \_\_\_\_\_  
Watson \_\_\_\_\_



COMMENTS: \_\_\_\_\_  
\_\_\_\_\_  
\_\_\_\_\_

PERMIT/APPLICATION NO \_\_\_\_\_  
ZONING DISTRICT \_\_\_\_\_  
MAGISTERIAL DISTRICT \_\_\_\_\_  
DATE SUBMITTED \_\_\_\_\_

**County of Prince Edward**

PLEASE PRINT OR TYPE

**PRINCE EDWARD COUNTY APPLICATION  
FOR SPECIAL USE PERMIT**

TO: PRINCE EDWARD COUNTY PLANNING COMMISSION      SPECIAL EXCEPTION REQUESTED:  
VIA: ZONING ADMINISTRATOR

The undersigned owner of the following described property hereby applies for a Special Use permit as provided in Section 5-124 of Article V, Site Plan requirements are found in Section 4-100 of Article IV Development Standards of the Zoning Ordinance of Prince Edward County, Virginia.

Applicant's Name: DWAYNE NORVELL NORVELL SILAS  
Applicant's Address: 5928 NINE MILE RD. RICHMOND VA 23228  
Applicant's Telephone Number: ( ) 804-737-2189

Present Land Use: SCHOOLS

Legal Description of Property with Deed Book and Page No. or Instrument No. ELEMENTARY MIDDLE SCHOOL 1603 ZION HILL RD. MAP 05181  
HIGH SCHOOL 1482 ZION HILL RD. MAP 05182

Tax Map # \_\_\_\_\_ Acreage : \_\_\_\_\_

Narrative statement evaluating effects on adjoining properties (noise, odor, dust, fumes, etc.): (Attach additional sheet if necessary.)  
SEE ATTACHMENT

Statement of general compatibility with adjacent and other properties in the zoning district. (Attach additional sheet if necessary.) \_\_\_\_\_

Height of Principal Building (s): Feet 7' 5162 Stories \_\_\_\_\_

APPLICANT'S STATEMENT: (if not owner(s) of property):

I hereby certify that I have the authority to make the foregoing application, that the information given is complete and correct to the best of my knowledge, and that development and/or construction will conform with the regulations as set forth in the Prince Edward County Zoning Ordinance as written and also with the description contained in this permit application.

[Signature]      3/16/23  
Signature of Applicant (if not property owner)      Date

PROPERTY OWNER(S) STATEMENT:

I hereby certify that I/We own the above described property, that the information given is complete and correct to the best of my knowledge, and the above person(s), group, corporation, or agent has the full and complete permission of the undersigned owner(s) to make application for a Conditional Use permit as set forth in the Prince Edward County Zoning Ordinance as written.

\_\_\_\_\_  
Signature of Property Owner(s)      Date

\_\_\_\_\_  
Signature of Property Owner(s)      Date

\_\_\_\_\_  
Signature of Property Owner(s)      Date

NOTE: THIS PERMIT APPLICATION IS NOT VALID UNLESS ALL PROPERTY OWNER(S) SIGNATURES ARE AFFIXED AND DATED. ATTACH ADDITIONAL SHEETS IF NECESSARY.

Application Fee \$300.00      Fee Received by [Signature]      Date 3/21/2023

The above mentioned application charges are nonrefundable, regardless of whether the permit application is approved or denied once submitted.

All checks for payment should be made payable to: Treasurer, Prince Edward County, Virginia.

Mail to: Department of Planning &  
Community Development  
P. O. Box 382  
Farmville, VA 23901  
(434) 392-8837



5928 NINE MILE RD. RICHMOND, VA 23223  
804-737-2189  
[www.norvellsigns.com](http://www.norvellsigns.com)

---

**County of Prince Edward  
Planning Commission**

**March, 16 2023**

**RE: Prince Edward Schools  
Special Use Permit  
Narrative**

**Application presented for Prince Edward High School, Prince Edward Middle School and Prince Edward Elementary schools to replace existing signs with similar size signs that incorporate electronic message centers. Signs are programmable to accommodate any code restrictions, i.e. brightness, message delay etc. These signs should not have any effects on adjacent properties or traffic.**

**Respectfully,**

**Dwayne Norvell**

*Dwayne Norvell*  
**Norvell Signs**

DISREGARD ANY DIMENSIONS AND ART ON THIS PAGE: ONLY USE DIMENSIONS ON LINE DRAWING PAGE AND ART FROM SIGNED ART PAGE.

7'-0"

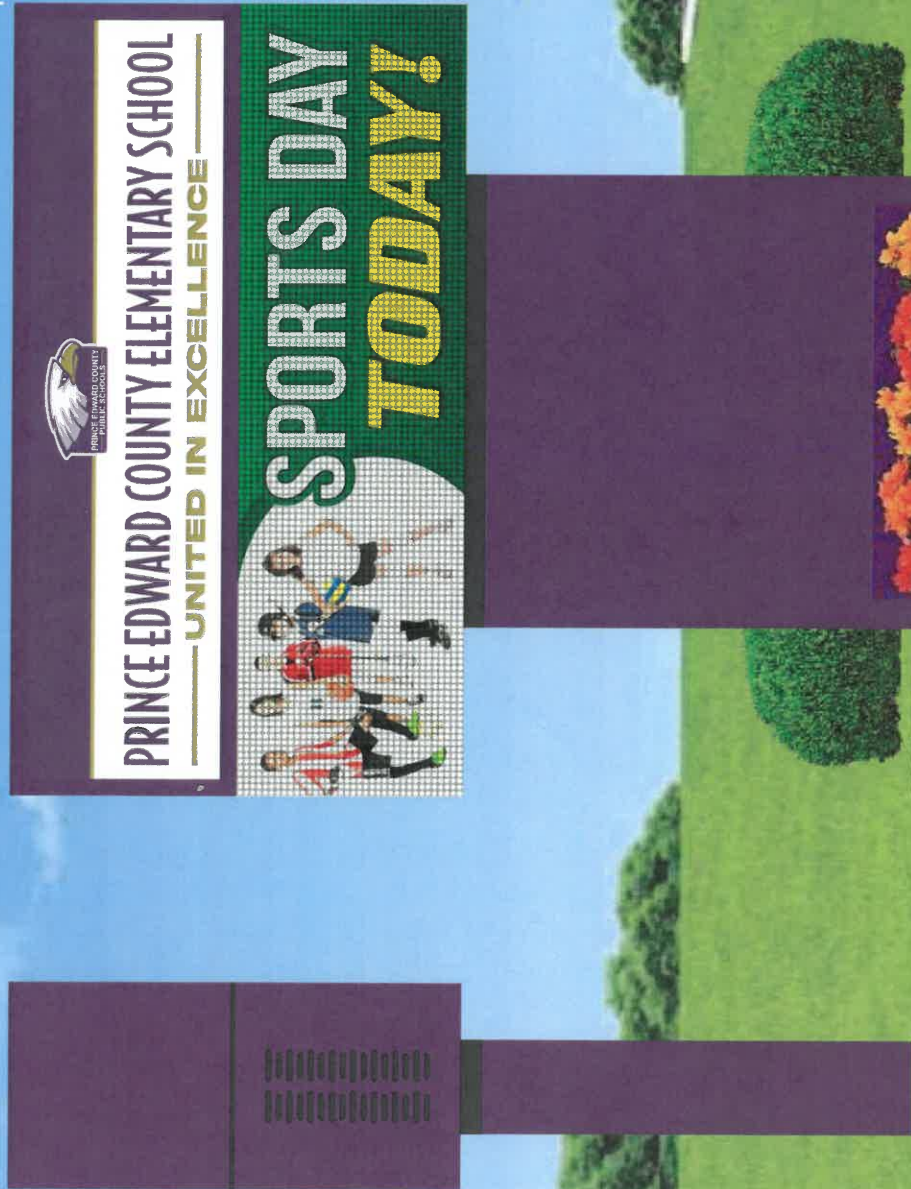

### SIGN SPECIFICATIONS

Color: Full Color /RGB text, pictures & video.  
Pitch: 20mm  
Matrix: 30x105  
Dimensions: 2'-0" x 7'-0" (Tall x Wide)  
Max # of Lines: 4  
Max Letter Per Line: 18  
Cabinet Size: 2'-0" x 7'-0" (Tall x Wide)  
Pedestal Size: 4" x 4" (Tall x Wide)



Cabinet PMS Color:  
**PANTONE 2627 C**

Colors used:

CMYK



PMS



Prince Edward Elementary

1666 Zion Hill Rd  
Farmville, VA 23901



VERSION #: R11152201

## Scope of Work:

### Electronic Message Center (EMC):

- 20mm, 30 x 105, 2'-0" x 7'-0", Cellular, double
- (4) 2"x2"x1/8" Angle @ 48"
- (4) Side Panel angles

### Fabrication:

- ID Cabinet
- Aluminum stick/extrusion frame, skin painted, 1.5" retainers, 3/16" clear poly-carbonate face, 2nd surface digital print, saddle mount

### Pole Skirt Panels

- (2) Aluminum skin .063", painted, per plan

### Vented Side Panels

- .063" aluminum, painted, routed holes for venting with VHB tape per plan

### Pole Supports w/ Anchor Bolt plates

- Painted per plan

### Structural:

- NA

### Installation:

- Receive and inspect sign from GRS
- Remove and dispose of existing signage
- Mount and attach sign per drawings
- Connect sign to existing power (to be ran by others)









\*\* Take completion photos. \*\*

\*\* Remove and/or level out any excess spoils. \*\*

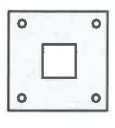
\*\* Leave a clean job site. \*\*

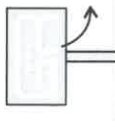

### Overview:

|                                                                                       |                                                                                       |                                                                                       |                                                                                       |                                                                                      |                                                                                     |                                                                                     |                                                                                     |                                                                                     |
|---------------------------------------------------------------------------------------|---------------------------------------------------------------------------------------|---------------------------------------------------------------------------------------|---------------------------------------------------------------------------------------|--------------------------------------------------------------------------------------|-------------------------------------------------------------------------------------|-------------------------------------------------------------------------------------|-------------------------------------------------------------------------------------|-------------------------------------------------------------------------------------|
|  |  |  |  |  |  |  |  |  |
| Double Sided                                                                          | 20mm                                                                                  | Anchor Bolt Retrofit                                                                  | GRS Install                                                                           | GRS Remove Existing Sign                                                             | Dedicated Circuit(s)                                                                | Cellular Modem                                                                      | Full Depth Cabinet                                                                  | Flat Faces                                                                          |

THE ART ON THIS PAGE IS THE ONLY VERSION OF ART AUTHORIZED TO BE USED FOR PRODUCTION.

\*\*This is visible artwork only and does not account for any bleed or area covered by retainers\*\*



# PRINCE EDWARD COUNTY ELEMENTARY SCHOOL

## — UNITED IN EXCELLENCE —

125

Colors used:

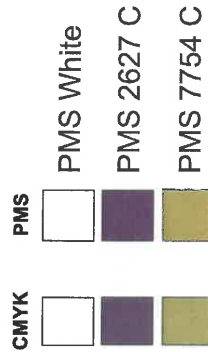

Cabinet PMS Color:  
**PANTONE 2627 C**



Client is responsible for ensuring that the proof is correct in all areas. Double-check spelling, grammar, layout and design before approving artwork. If a proof containing errors is approved by client, the client is responsible for payment of original cost as well as corrections, revisions, and re-makes. This custom artwork is not intended to provide an exact match between ink, vinyl, paint or EMC color. Brickwork, masonry and landscaping is not included in the proposal unless otherwise specifically stated. EMC images shown are simulated. Sign is designed to be illuminated at all times. Sketches are based off of this premise. This is a custom made product, built by hand for people by people. Small blemishes/imperfections may occur and can be expected with hand made products. Industry standard is to view this product from a minimum distance of 10 feet to determine quality acceptability.

Signed Art:

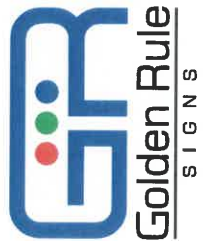

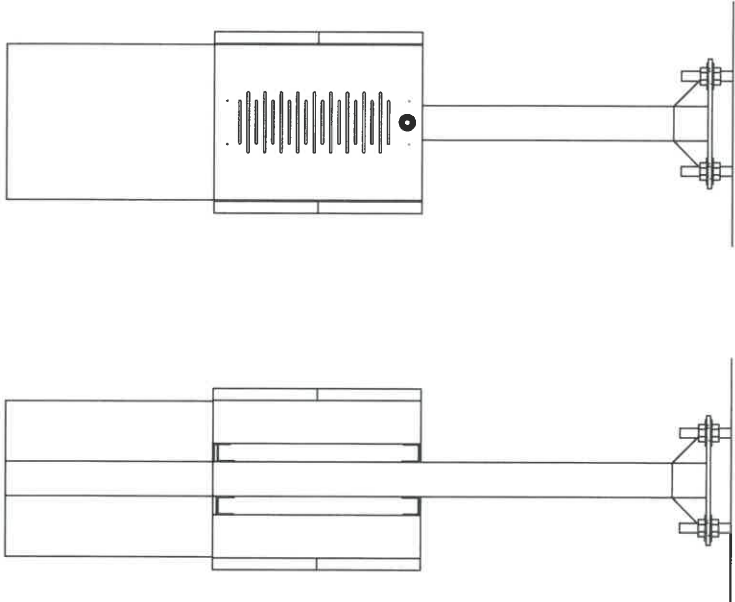
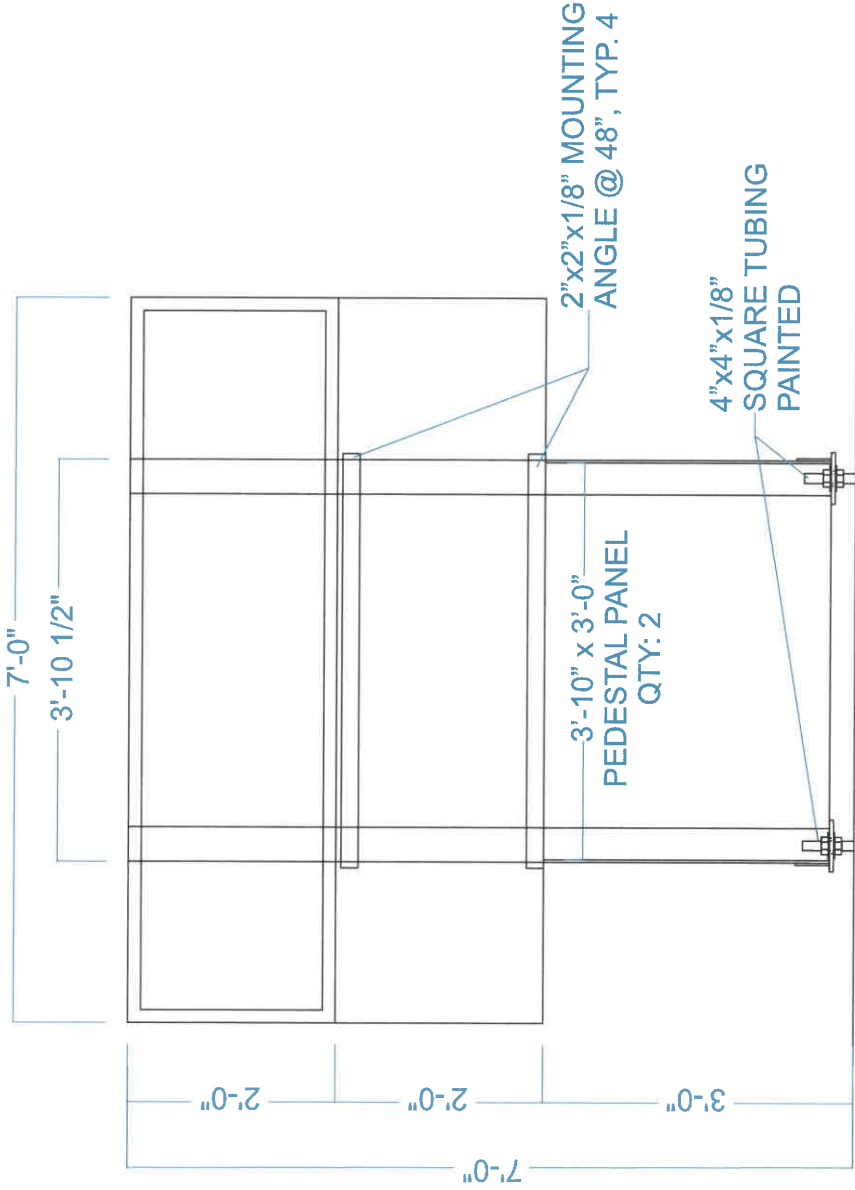

Notes:



|                                                                                     |                      |
|-------------------------------------------------------------------------------------|----------------------|
|  | Double Sided         |
|  | Full Depth Cabinet   |
|  | Anchor Bolt Retrofit |

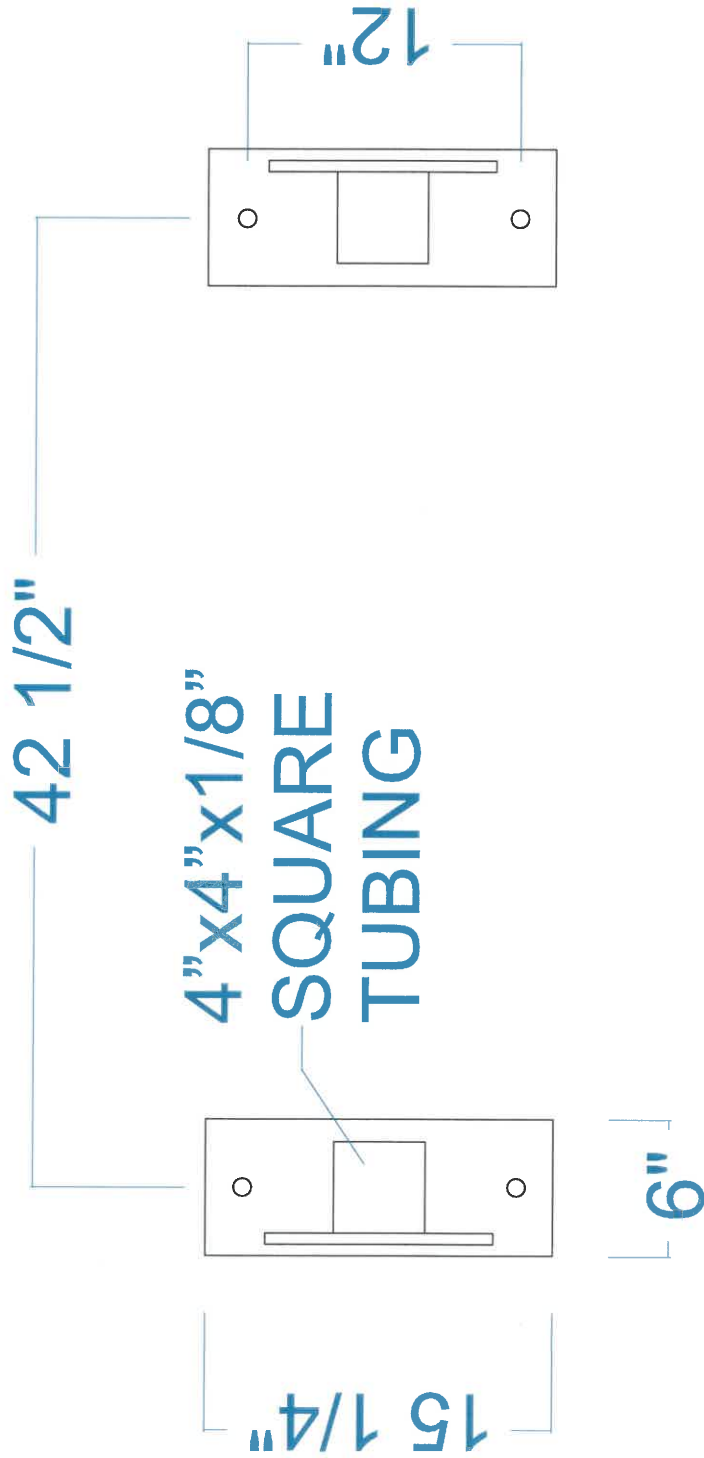

Notes:

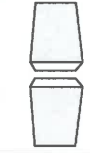
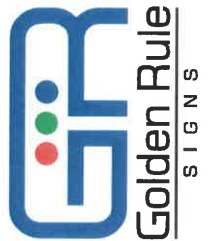

Double Sided



Full Depth Cabinet



Anchor Bolt Retrofit

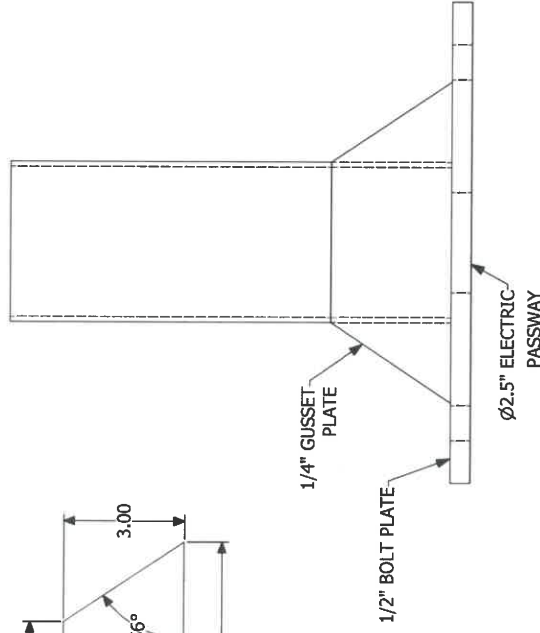
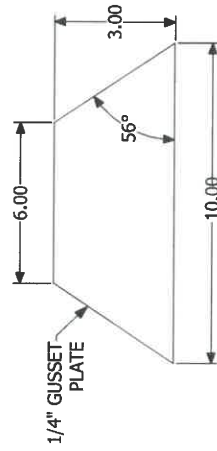
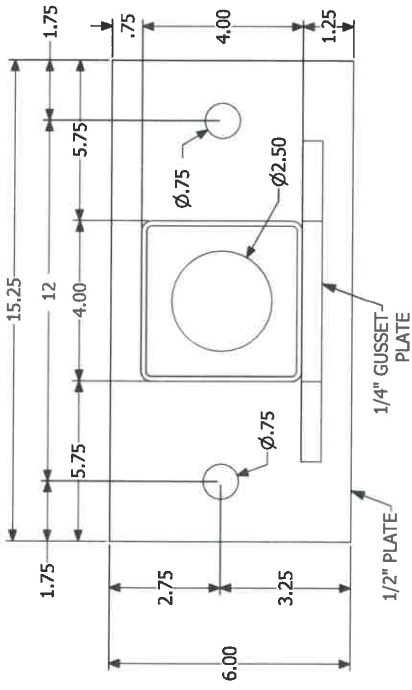
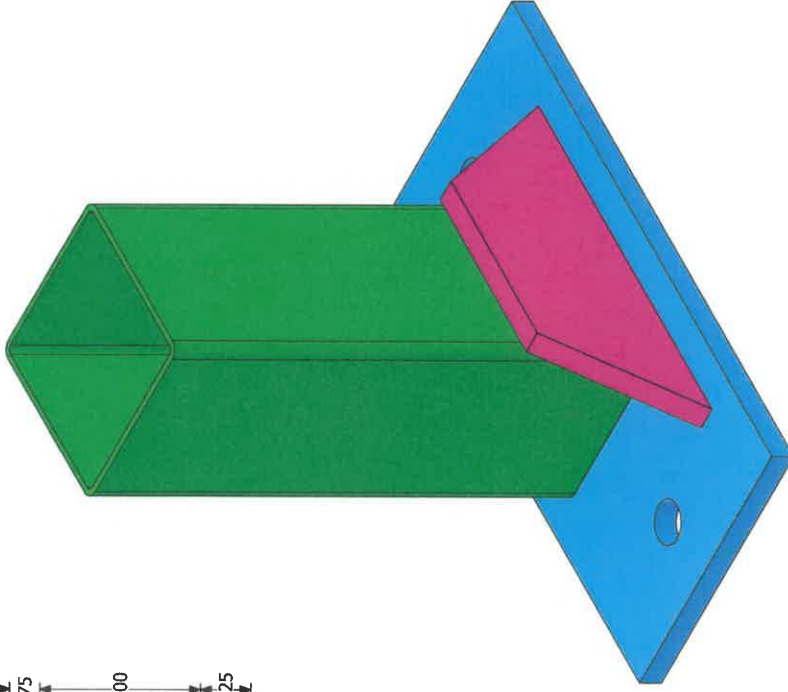

## Notes:



Double Sided



Full Depth Cabinet



Anchor Bolt Retrofit



Side Panel Angle Length (based on USMB)

- 3" USMB = 7" Side Panel Angles
- 4" USMB = 8" Side Panel Angles**
- 5" USMB = 9" Side Panel Angles
- 6" USMB = 10" Side Panel Angles
- 7" USMB = 11" Side Panel Angles
- 8" USMB = 12" Side Panel Angles

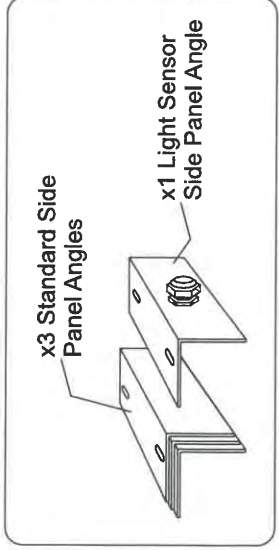

**DO NOT PENETRATE CABINET!**  
Penetrating cabinet will void warranty

\*Top EMC Angles lowered for bolt head clearance & ID Cabinet mounting

Double Sided VHB tape attached to Vented Side Panel

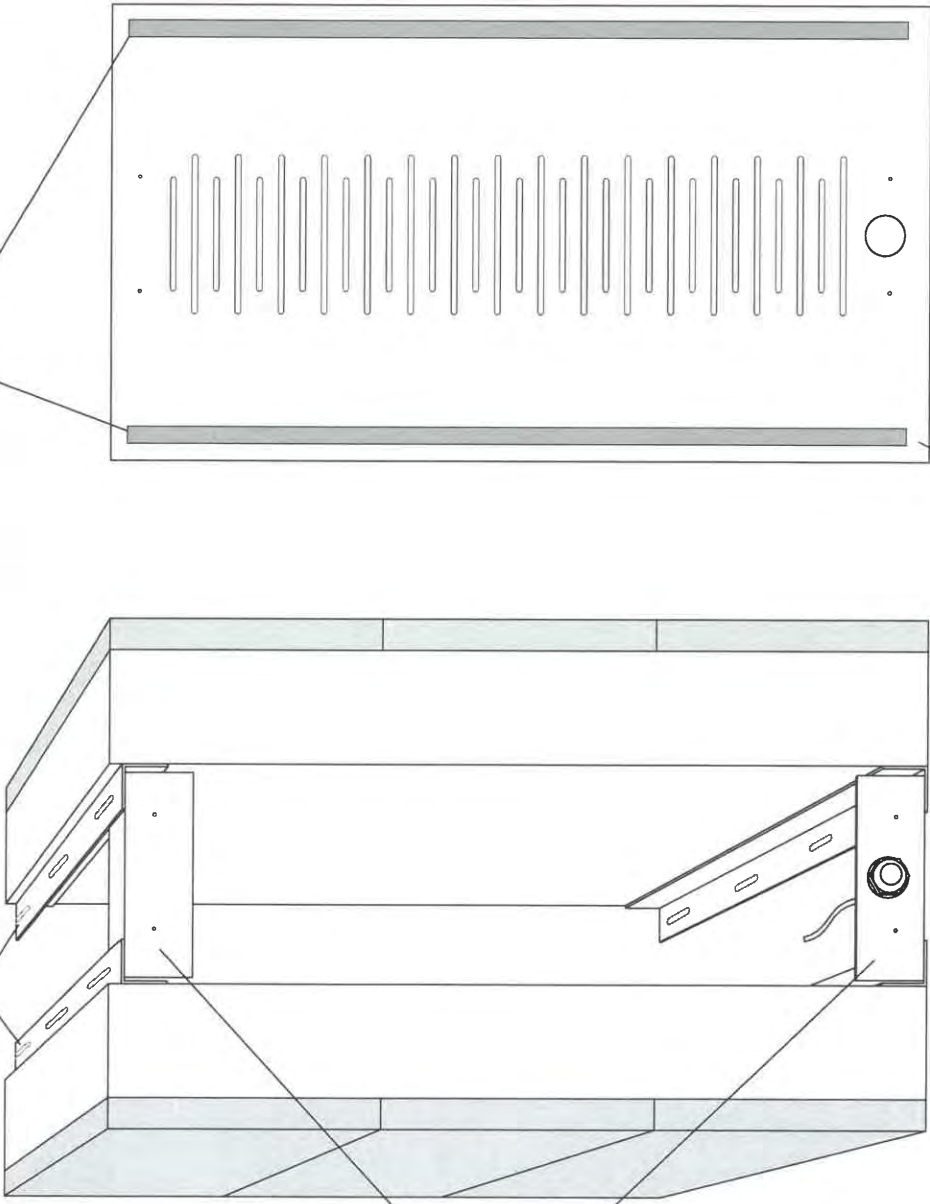

Vented Side Panel secured to Side Panel Angles w/ self tapping screws

Vented Side Panel Mounting

Notes:

- Set includes:
- x2 Vented Panels (x1 with light sensor hole)
  - x3 Standard Side Panel Angles
  - x1 Light Sensor & Side Panel Angle



Vented Side Panel Width (based on USMB)

- 3" USMB = 17" Vented Side Panel
- 4" USMB = 18" Vented Side Panel**
- 5" USMB = 19" Vented Side Panel
- 6" USMB = 20" Vented Side Panel
- 7" USMB = 21" Vented Side Panel
- 8" USMB = 22" Vented Side Panel

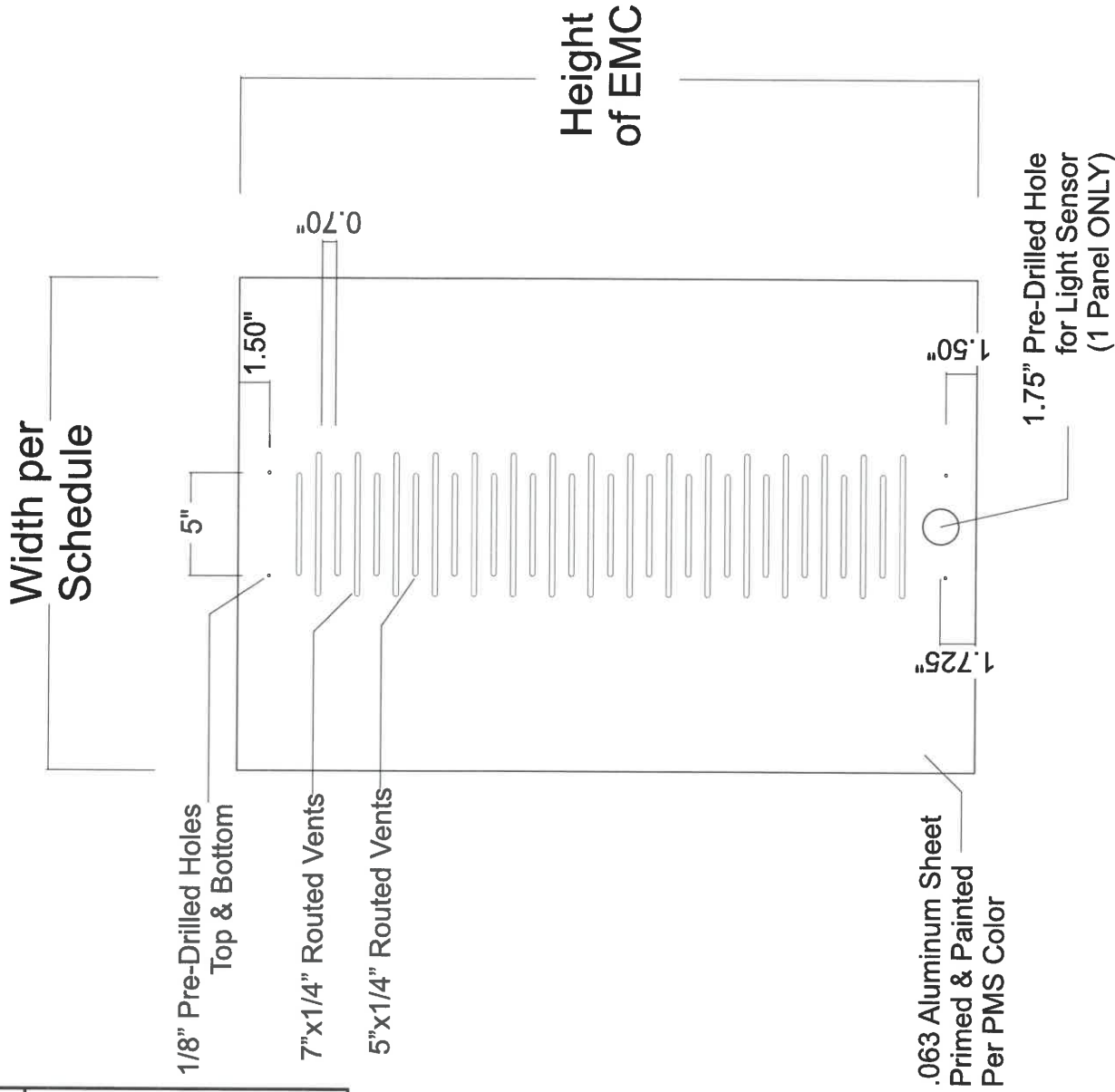

Notes:

- Set includes:
- x2 Vented Panels (x1 with light sensor hole)
  - x3 Standard Side Panel Angles
  - x1 Light Sensor & Side Panel Angle



Light Sensor Angle Length (based on USMB)

- 3" USMB = 7" Side Panel Angles
- 4" USMB = 8" Side Panel Angles**
- 5" USMB = 9" Side Panel Angles
- 6" USMB = 10" Side Panel Angles
- 7" USMB = 11" Side Panel Angles
- 8" USMB = 12" Side Panel Angles

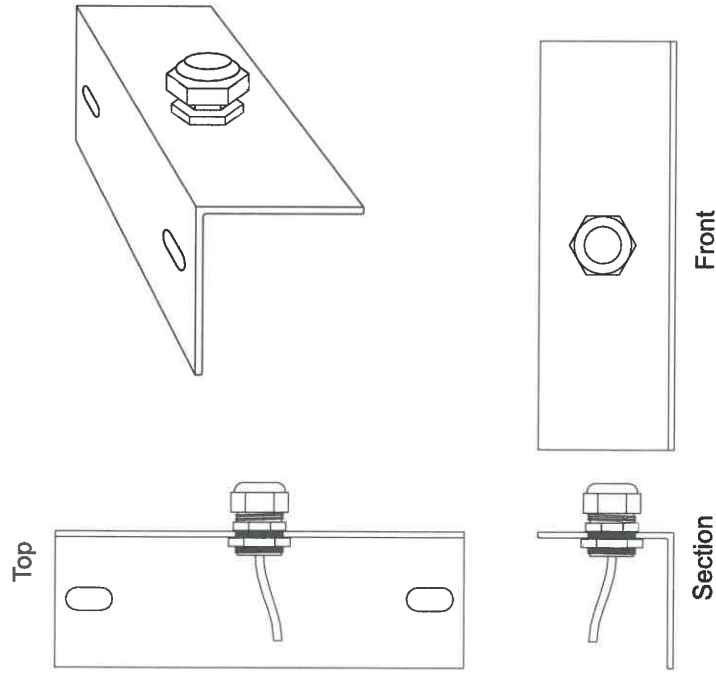

131

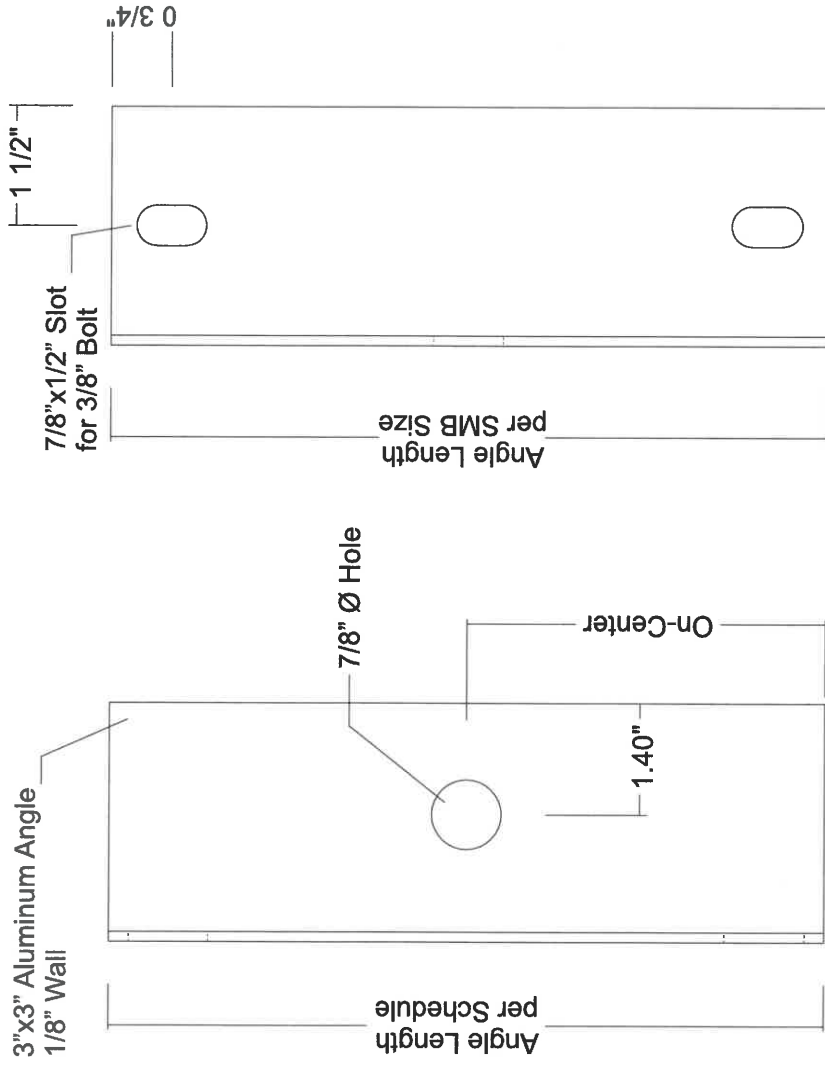

Light Sensor Face

Mounting Face

Light Sensor Mounting Angle

Notes:

- Set includes:
- x2 Vented Panels (x1 with light sensor hole)
  - x3 Standard Side Panel Angles
  - x1 Light Sensor & Side Panel Angle



\*\*\*All ID Cabinet electrical components to be wide range power to serve up to 240 volts\*\*\*

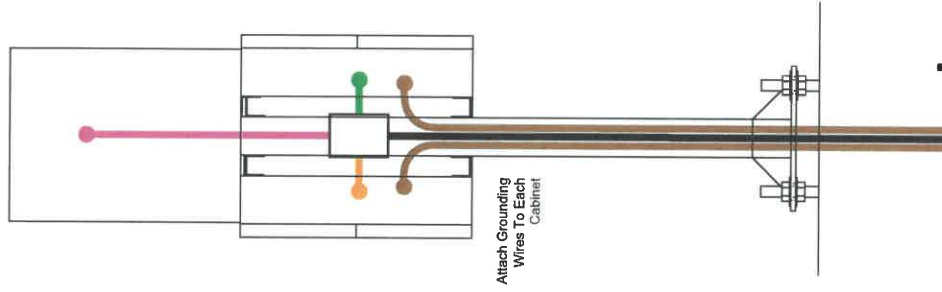
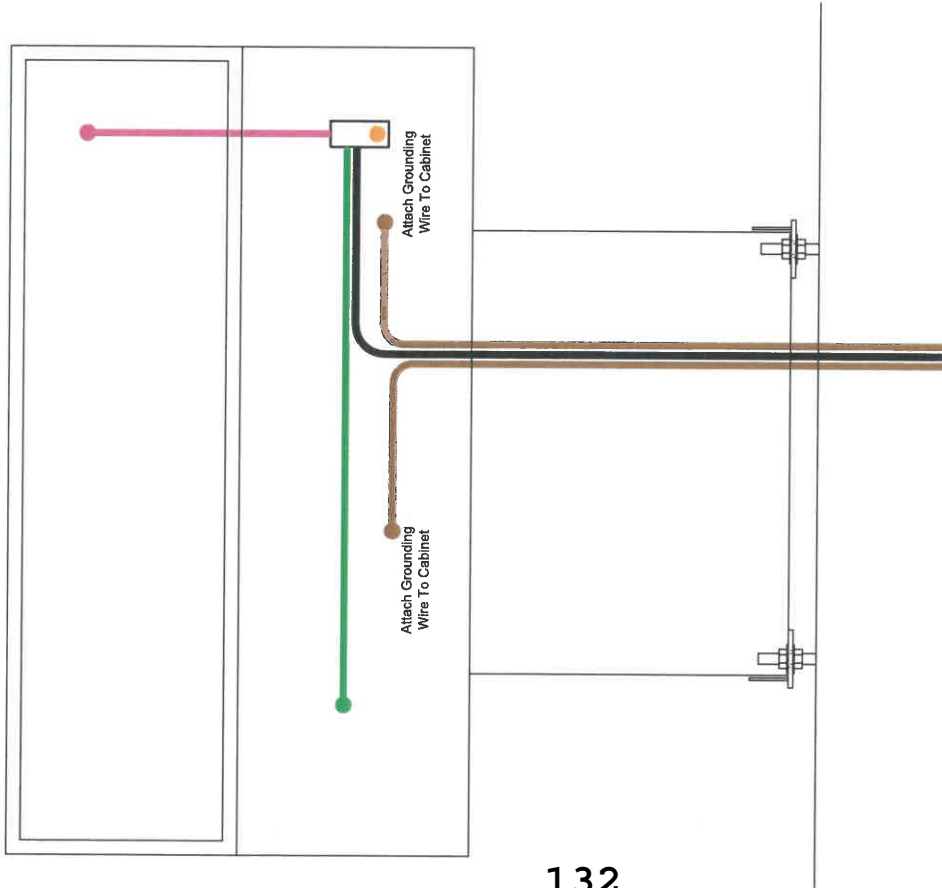

**120** volts  
**12** amps

Dedicated  
Circuit(s)

National Electric Code requires that lines not exceed 80% load of any one circuit.

# Wiring Diagram



## LED Installation Manual

### Key:

- 6GA. COPPER AND 1/2" ROD X6
- ID CABINET POWER WHIP
- PRIMARY EMC WHIP
- SECONDARY EMC WHIP
- CLIENT PROVIDED PRIMARY



GRS REQUIRES THAT THE SIGN OPERATE ON AT LEAST 1 DEDICATED CIRCUIT AND RECOMMENDS 1 CIRCUIT PER L.E.D. DISPLAY. WARRANTY REQUIRES EACH L.E.D. DISPLAY TO HAVE A MINIMUM 1/2" COPPER, IN-EARTH GROUND ROD WITH CONTINUOUS 6 GAUGE COPPER WIRE, 6' LONG LOCATED 8 FEET FROM THE BASE OF THE SIGN.



Cellular  
Modem

Visit [resource.impactledsigns.com](http://resource.impactledsigns.com) for more details

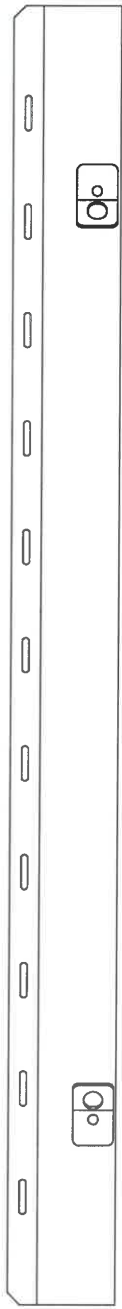
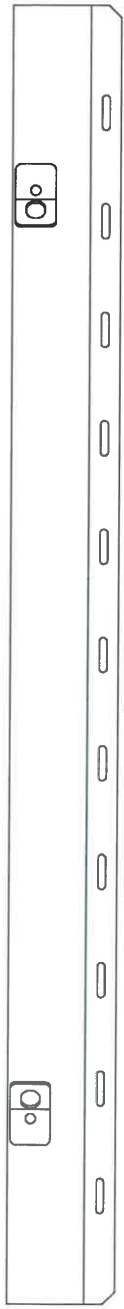

## TOP VIEW

2134 [84]

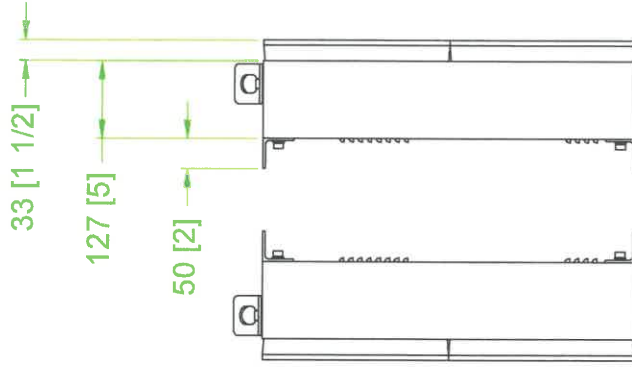

## SIDE VIEW

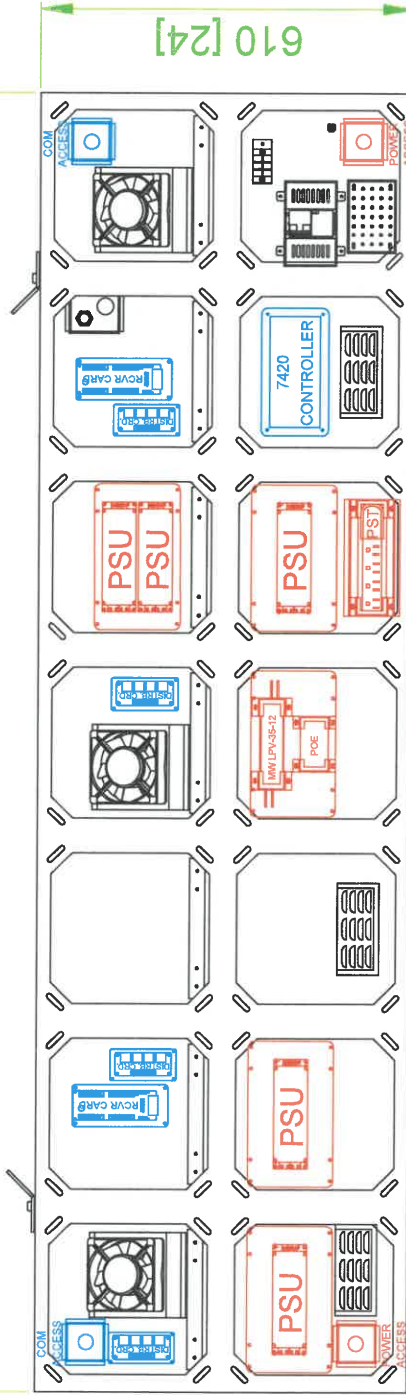

## FRONT VIEW



Version: 2\_0100017\_2020

MODEL NO:

**20mm 030x105**

- NOTES:
- 1. INSTALL PER NATIONAL ELECTRIC CODE
  - 1. FASTEN USING APPROPRIATELY RATED FASTENERS
  - 1. DISPLAY IS REAR VENTILATED. DO NOT BLOCK OF SEAL OFF
  - 1. IMPACT IS NOT RESPONSIBLE FOR THE MOUNTING. HARDWARE OR THE INTEGRITY OF THE STRUCTURE TO WHICH THE DISPLAY IS MOUNTED.
  - 1. IMPACT IS NOT RESPONSIBLE FOR THE MAIN POWER DISCONNECT.

Volts: 120  
 Max. Watts: 1250  
 Max. Actual Amps: 5.21  
 Typical Amps: 1.82

WEIGHT:  
 75 lbs.  
 (per face)

UNITS:  
 MM  
 (INCH)

COPYRIGHT. IMPACT LED SIGNS. ALL RIGHTS RESERVED.  
 UNAUTHORIZED REPRODUCTION AND DISTRIBUTION PROHIBITED.

Electrical Information Per Face: 1 (120 Volt/15 Amp circuits. Grounding rod installed per each face, (see Installation Manual.)

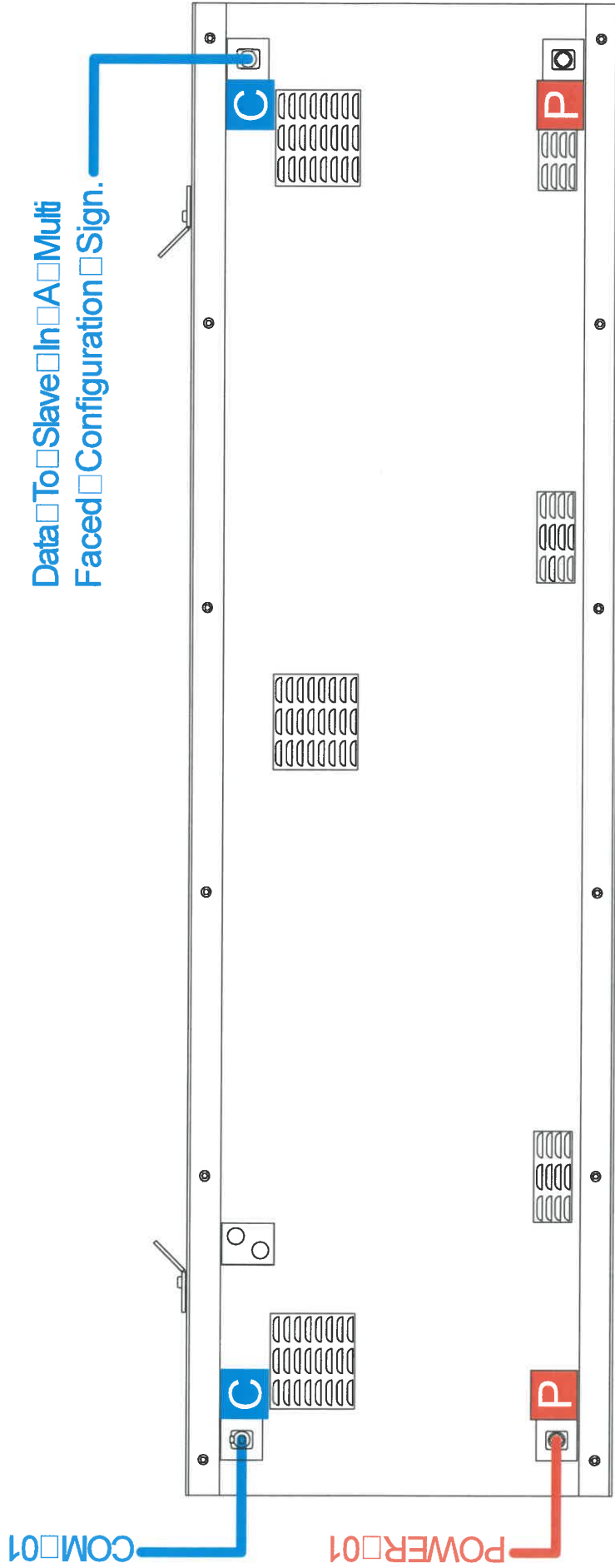

## BACK VIEW & CIRCUIT SCHEMATIC



MODEL NO: **20mm 030x105**

NOTES:

- INSTALL PER NATIONAL ELECTRIC CODE
- FASTEN USING APPROPRIATELY RATED FASTENERS
- DISPLAY IS REAR VENTILATED. DO NOT BLOCK OF SEAL OFF
- IMPACTLED IS NOT RESPONSIBLE FOR THE MOUNTING HARDWARE OR THE INTEGRITY OF THE STRUCTURE TO WHICH THE DISPLAY IS MOUNTED.
- IMPACT IS NOT RESPONSIBLE FOR THE MAIN POWER DISCONNECT.

Volts: 120  
Max. Watts: 1250  
Max. Actual Amps: 5.21  
Typical Amps: 1.82

WEIGHT: 75 lbs. (per face)  
UNITS: MM (INCH)

COPYRIGHT IMPACT LED SIGNS. ALL RIGHTS RESERVED. UNAUTHORIZED REPRODUCTION AND DISTRIBUTION PROHIBITED.



Notes:

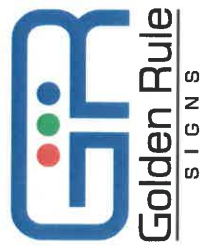



Sign Location:

1666 Zion Hill Rd  
Farmville, VA 23901





DISREGARD ANY DIMENSIONS AND ART ON THIS PAGE: ONLY USE DIMENSIONS ON LINE DRAWING PAGE AND ART FROM SIGNED ART PAGE.

7'-0"



### SIGN SPECIFICATIONS

Color: Full Color / RGB text, pictures & video.  
 Pitch: 20mm  
 Matrix: 30x105  
 Dimensions: 2'-0" x 7'-0" (Tall x Wide)  
 Max # of Lines: 4  
 Max Letter Per Line: 18  
 Cabinet Size: 2'-0" x 7'-0" (Tall x Wide)  
 Pedestal Size: 4' x 4' (Tall x Wide)



Cabinet PMS Color:

**PANTONE 2627 C**

Colors used:

CMYK



PMS



PMS White  
 PMS 2627 C  
 PMS 7754 C

Prince Edward Middle School

VERSION #: R11152201



1603 Zion Hill Rd.  
 Farmville, VA 23901

## Scope of Work:

### Electronic Message Center (EMC):

- 20mm, 30 x 105, 2'-0" x 7'-0", Cellular, double
- (4) 2"x2"x1/8" Angle @ 48"
- (4) Side Panel angles

### Fabrication:

- ID Cabinet
- Aluminum stick/extrusion frame, skin painted, 1.5" retainers, 3/16" clear poly-carbonate face, 2nd surface digital print, saddle mount

### Pole Skirt Panels

- (2) Aluminum skin .063", painted, per plan

### Vented Side Panels

- .063" aluminum, painted, routed holes for venting with VHB tape per plan

### Pole Supports w/ Anchor Bolt plates

- Painted per plan

### Structural:

- NA

### Installation:

- Receive and inspect sign from GRS
- Remove and dispose of existing signage
- Mount and attach sign per drawings
- Connect sign to existing power (to be ran by others)









\*\* Take completion photos. \*\*

\*\* Remove and/or level out any excess spoils. \*\*

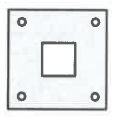
\*\* Leave a clean job site. \*\*

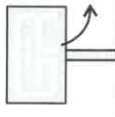

### Overview:

|                                                                                       |                                                                                       |                                                                                       |                                                                                       |                                                                                      |                                                                                     |                                                                                     |                                                                                     |                                                                                     |
|---------------------------------------------------------------------------------------|---------------------------------------------------------------------------------------|---------------------------------------------------------------------------------------|---------------------------------------------------------------------------------------|--------------------------------------------------------------------------------------|-------------------------------------------------------------------------------------|-------------------------------------------------------------------------------------|-------------------------------------------------------------------------------------|-------------------------------------------------------------------------------------|
|  |  |  |  |  |  |  |  |  |
| Double Sided                                                                          | 20mm                                                                                  | Anchor Bolt Retrofit                                                                  | GRS Install                                                                           | GRS Remove Existing Sign                                                             | Dedicated Circuit(s)                                                                | Cellular Modem                                                                      | Full Depth Cabinet                                                                  | Flat Faces                                                                          |

THE ART ON THIS PAGE IS THE ONLY VERSION OF ART AUTHORIZED TO BE USED FOR PRODUCTION.

\*\*This is visible artwork only and does not account for any bleed or area covered by retainers\*\*



139

Colors used:

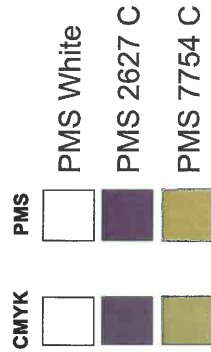

Cabinet PMS Color:  
**PANTONE 2627 C**



Flat Faces  
Double Sided

Client is responsible for ensuring that the proof is correct in all areas. Double-check spelling, grammar, layout and design before approving artwork. If a proof containing errors is approved by client, the client is responsible for payment of original cost as well as corrections, revisions, and re-makes. This custom artwork is not intended to provide an exact match between ink, vinyl, paint or EMC color. Brickwork, masonry and landscaping is not included in the proposal unless otherwise specifically stated. EMC images shown are simulated. Sign is designed to be illuminated at all times. Sketches are based off of this premise. This is a custom made product, built by hand for people by people. Small blemishes/imperfections may occur and can be expected with hand made products. Industry standard is to view this product from a minimum distance of 10 feet to determine quality acceptability.

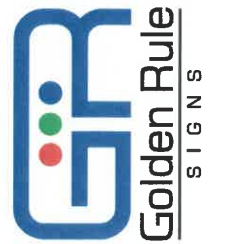

Signed Art:



# Design Overview

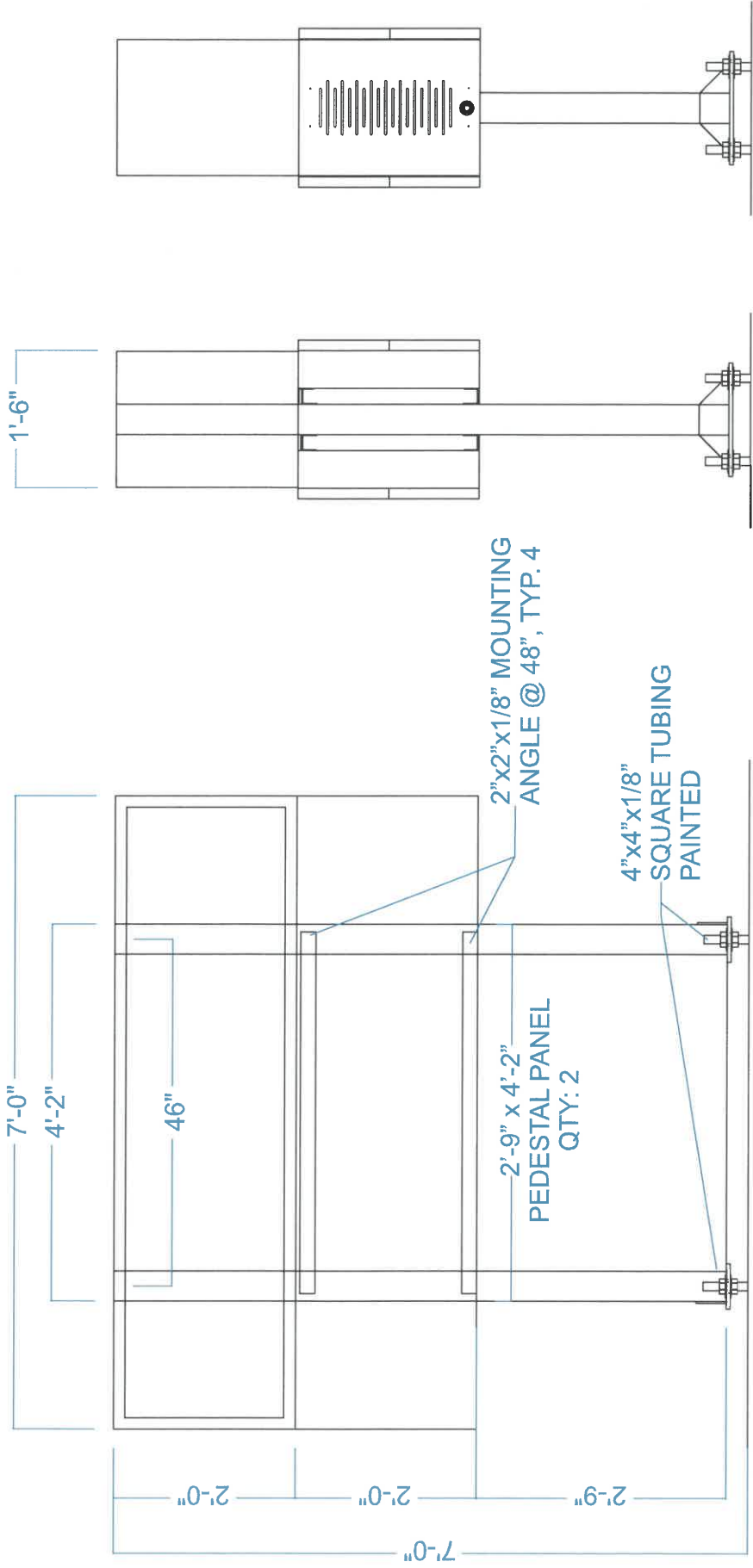

140

## Notes:

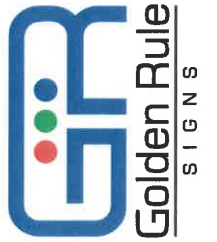

Full Depth Cabinet

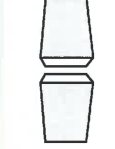

Double Sided

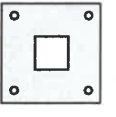

Anchor Bolt Retrofit

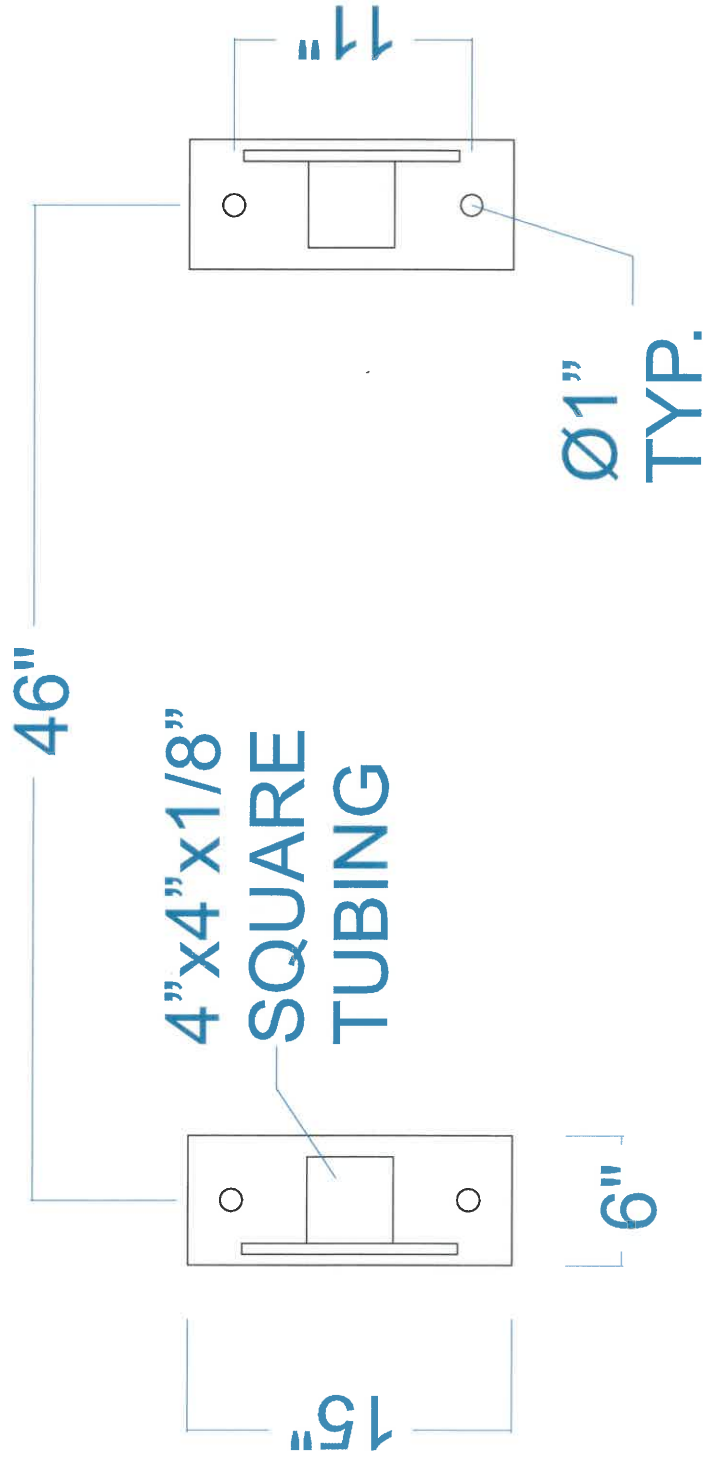

Notes:



Double  
Sided



Full Depth  
Cabinet

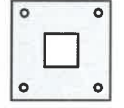

Anchor Bolt  
Retrofit

# Design Overview

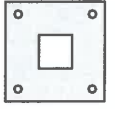
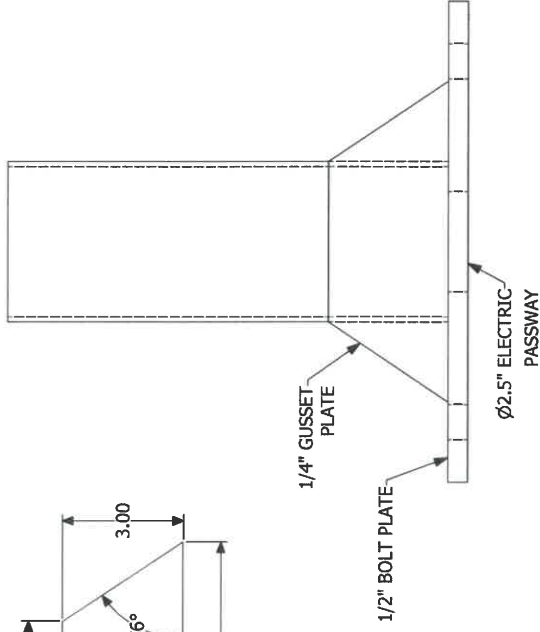
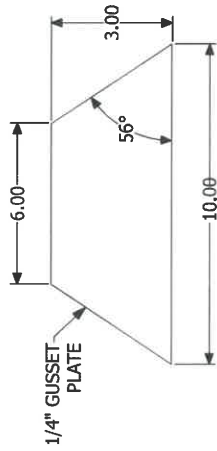
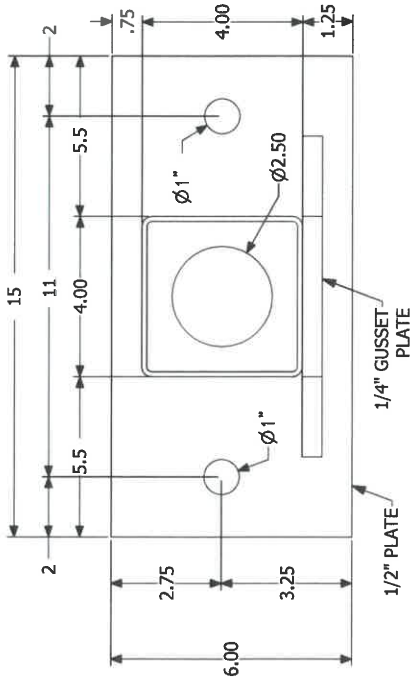
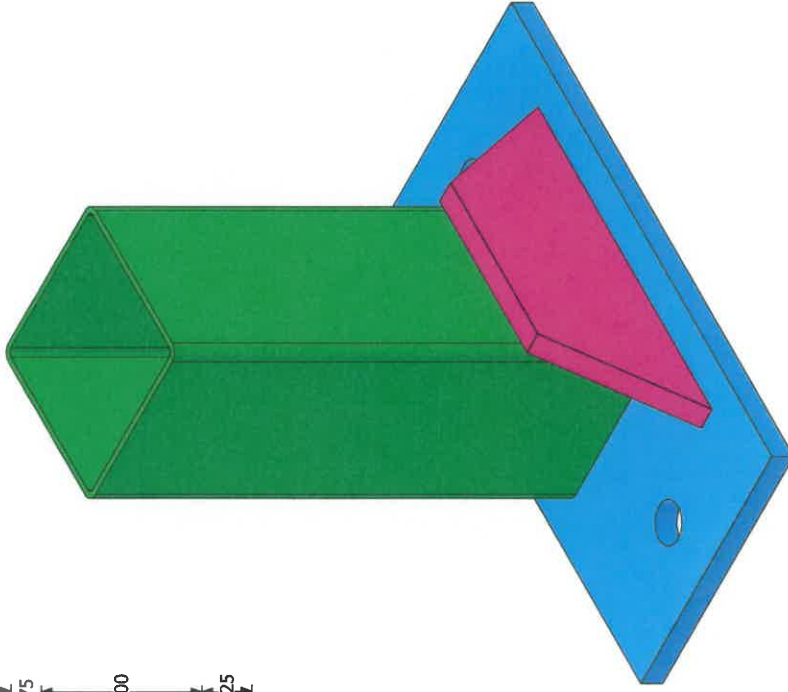

Anchor Bolt Retrofit



Full Depth Cabinet



Double Sided

Notes:



Side Panel Angle Length (based on USMB)

- 3" USMB = 7" Side Panel Angles
- 4" USMB = 8" Side Panel Angles**
- 5" USMB = 9" Side Panel Angles
- 6" USMB = 10" Side Panel Angles
- 7" USMB = 11" Side Panel Angles
- 8" USMB = 12" Side Panel Angles

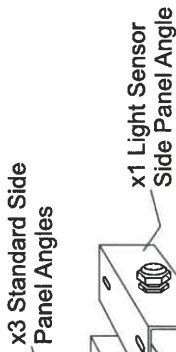

**DO NOT PENETRATE CABINET!**  
Penetrating cabinet will void warranty

\*Top EMC Angles lowered for bolt head clearance & ID Cabinet mounting

Double Sided VHB tape attached to Vented Side Panel

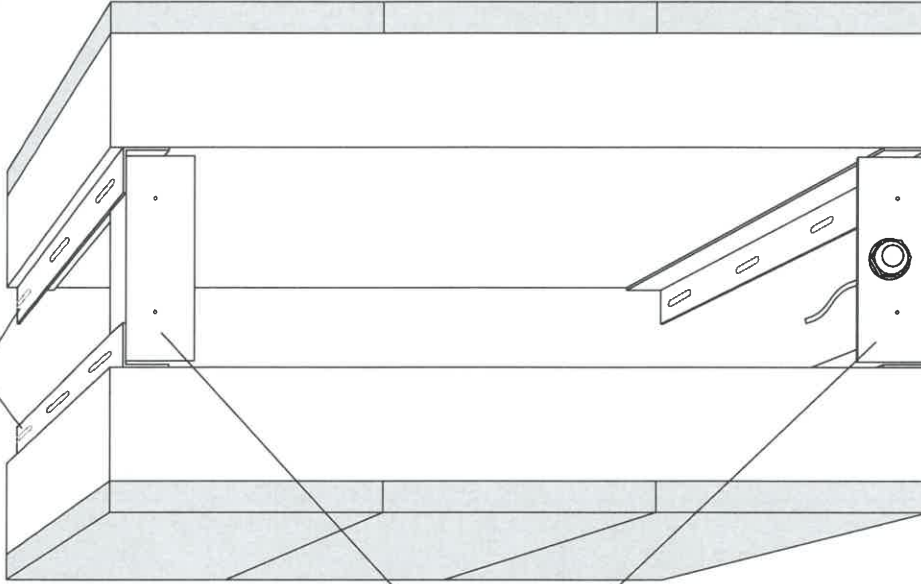

Vented Side Panel secured to Side Panel Angles w/ self tapping screws

# Vented Side Panel Mounting

## Notes:

Set includes:

- x2 Vented Panels (x1 with light sensor hole)
- x3 Standard Side Panel Angles
- x1 Light Sensor & Side Panel Angle



Vented Side Panel Width (based on USMB)

- 3" USMB = 17" Vented Side Panel
- 4" USMB = 18" Vented Side Panel
- 5" USMB = 19" Vented Side Panel
- 6" USMB = 20" Vented Side Panel
- 7" USMB = 21" Vented Side Panel
- 8" USMB = 22" Vented Side Panel

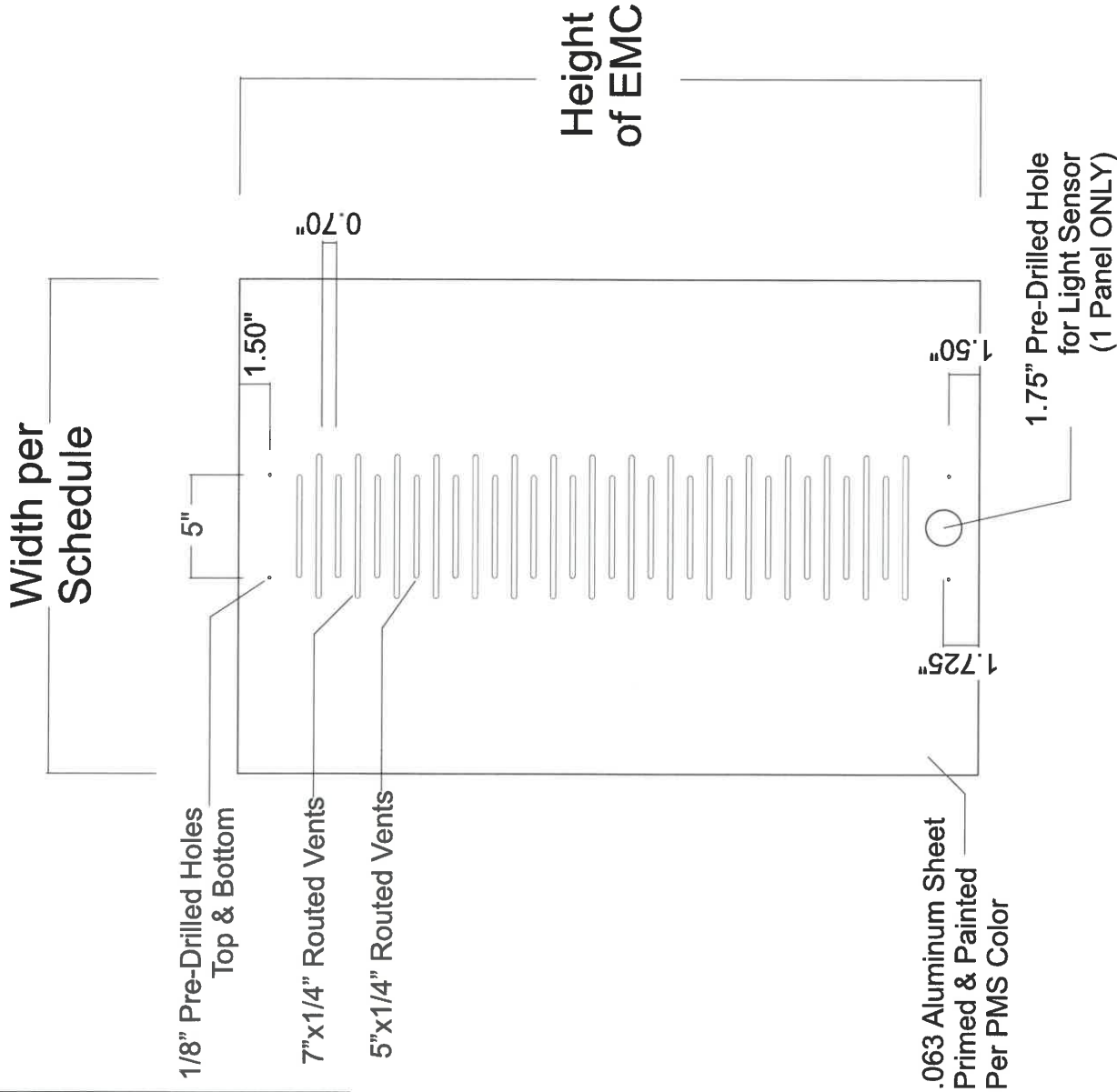

Notes:

- Set includes:**
- x2 Vented Panels (x1 with light sensor hole)
  - x3 Standard Side Panel Angles
  - x1 Light Sensor & Side Panel Angle





Light Sensor Angle Length (based on USMB)

- 3" USMB = 7" Side Panel Angles
- 4" USMB = 8" Side Panel Angles**
- 5" USMB = 9" Side Panel Angles
- 6" USMB = 10" Side Panel Angles
- 7" USMB = 11" Side Panel Angles
- 8" USMB = 12" Side Panel Angles

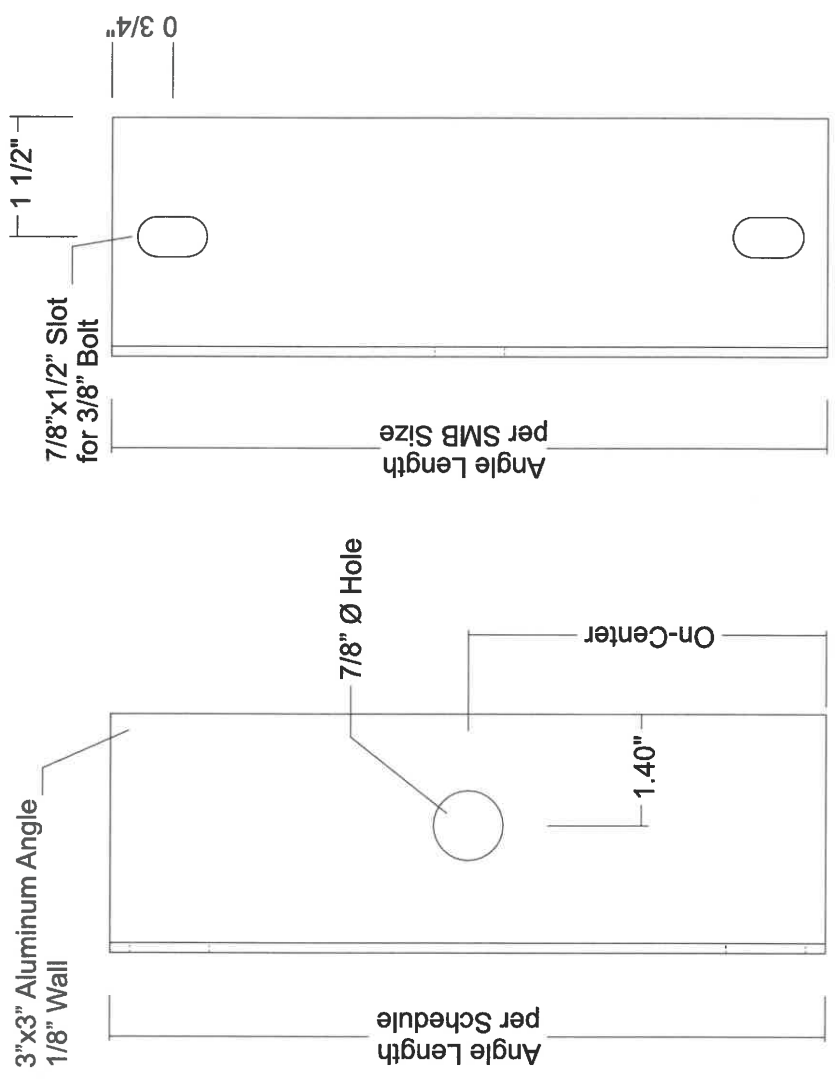
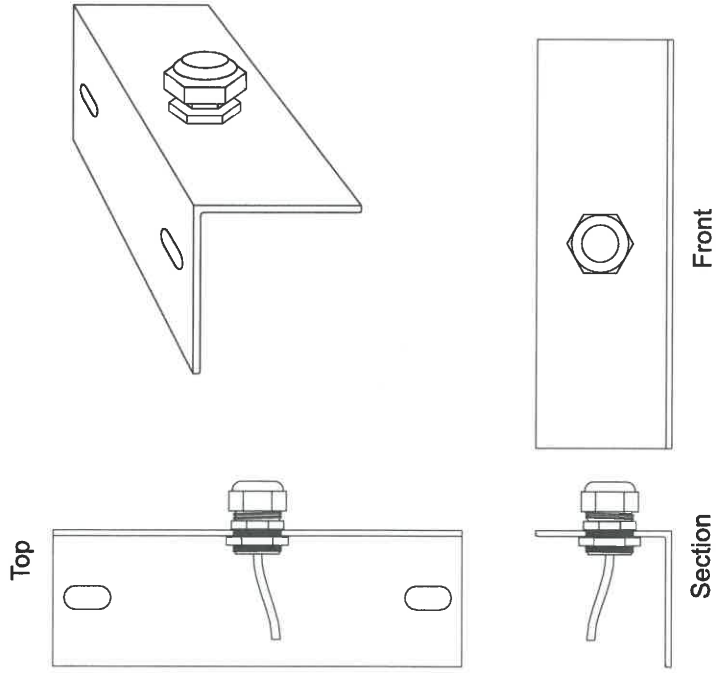

Mounting Face

Light Sensor Face

Light Sensor Mounting Angle

Notes:

- Set includes:
- x2 Vented Panels (x1 with light sensor hole)
  - x3 Standard Side Panel Angles
  - x1 Light Sensor & Side Panel Angle



\*\*\*All ID Cabinet electrical components to be wide range power to serve up to 240 volts\*\*\*

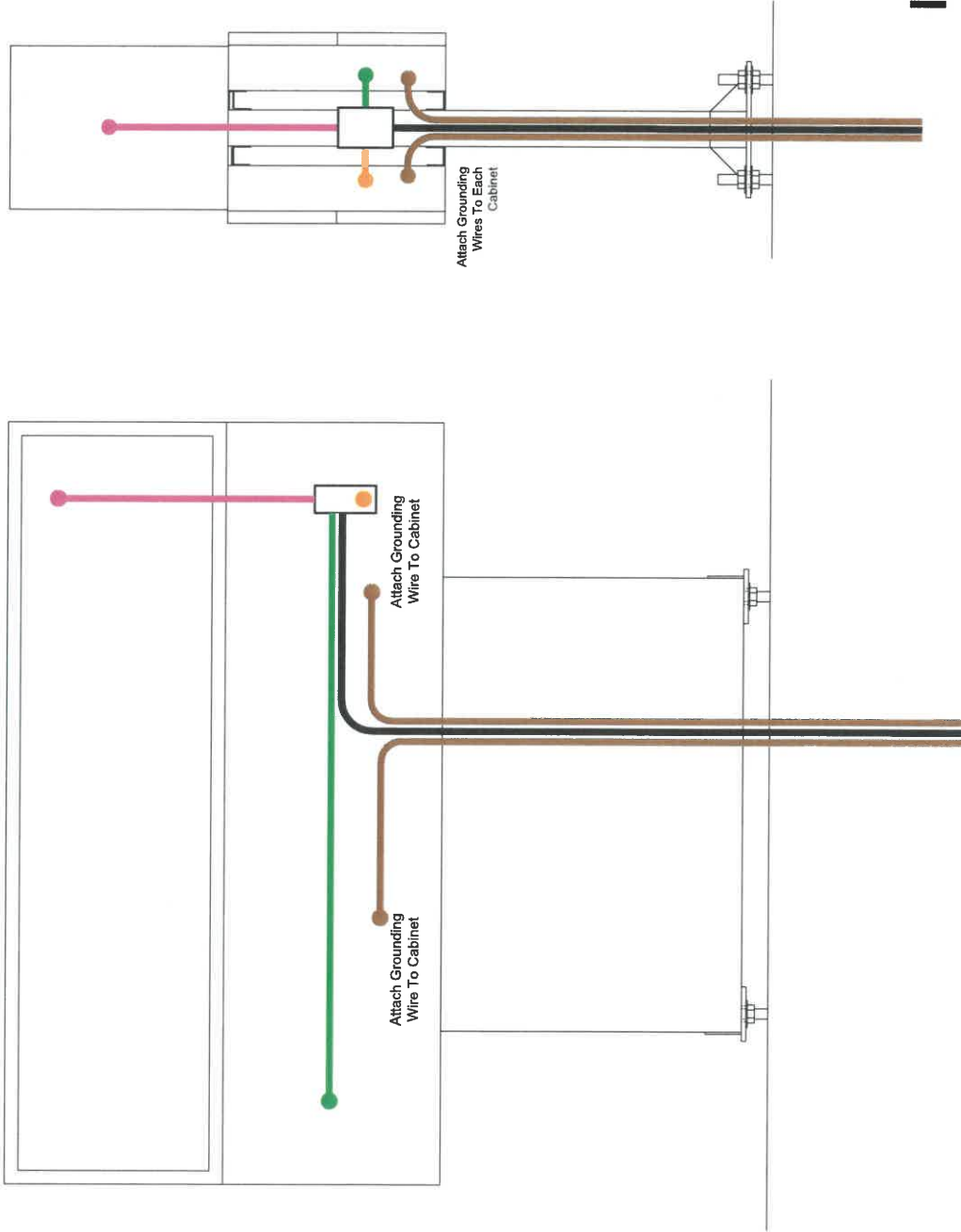

**120** volts  
**12** amps

Dedicated  
Circuit(s)

National Electric Code requires that lines not exceed 80% load of any one circuit.

# Wiring Diagram



## LED Installation Manual

### Key:

- 6GA. COPPER AND 1/2" ROD X6'
- ID CABINET POWER WHIP
- PRIMARY EMC WHIP
- SECONDARY EMC WHIP
- CLIENT PROVIDED PRIMARY



GRS REQUIRES THAT THE SIGN OPERATE ON AT LEAST 1 DEDICATED CIRCUIT AND RECOMMENDS 1 CIRCUIT PER L.E.D. DISPLAY. WARRANTY REQUIRES EACH L.E.D. DISPLAY TO HAVE A MINIMUM 1/2" COPPER, IN-EARTH GROUND ROD WITH CONTINUOUS 6 GAUGE COPPER WIRE, 6' LONG LOCATED 8 FEET FROM THE BASE OF THE SIGN.

4G  
Cellular  
Modem

Visit [resource.impactledsigns.com](http://resource.impactledsigns.com) for more details

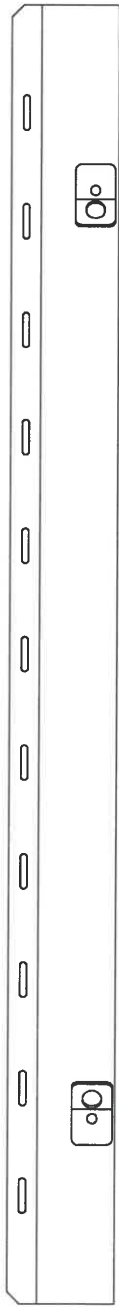
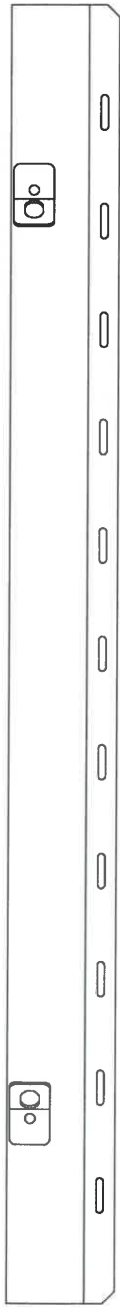

## TOP VIEW

2134 [84]

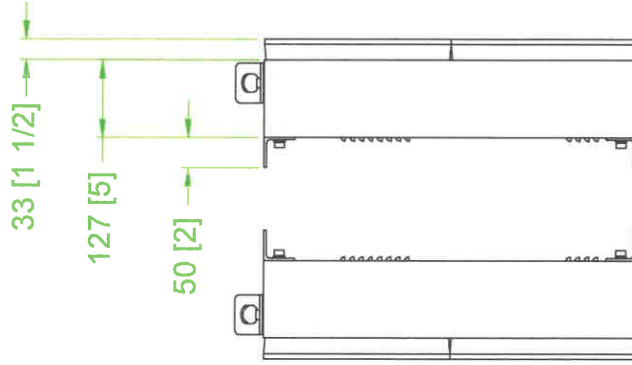

## SIDE VIEW

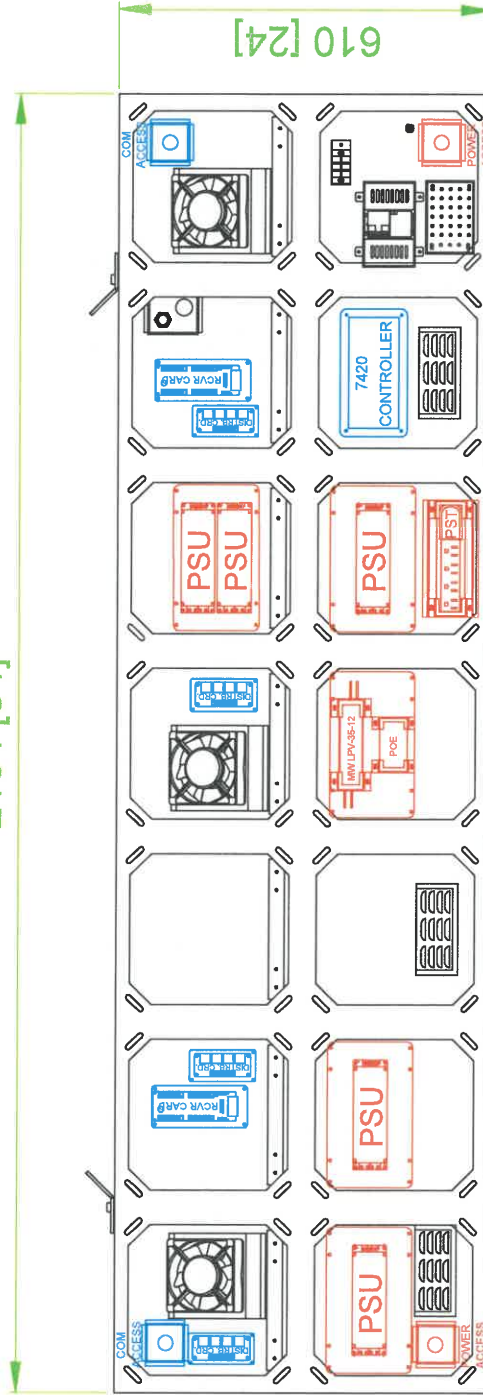

## FRONT VIEW



MODEL NO: **20mm 030x105**

NOTES:  
 1 INSTALL PER NATIONAL ELECTRIC CODE  
 1 FASTEN USING APPROPRIATELY RATED FASTENERS  
 1 DISPLAY IS REAR VENTILATED. DO NOT BLOCK OF SEAL OFF  
 1 IMPACT IS NOT RESPONSIBLE FOR THE MOUNTING HARDWARE OR THE INTEGRITY OF THE STRUCTURE TO WHICH THE DISPLAY IS MOUNTED.  
 1 IMPACT IS NOT RESPONSIBLE FOR THE MAIN POWER DISCONNECT.

Volts: 120  
 Max. Watts: 1250  
 Max. Actual Amps: 5.21  
 Typical Amps: 1.82

WEIGHT: 75 lbs. (per face)

UNITS: MM (INCH)

COPYRIGHT. IMPACT LED SIGNS. ALL RIGHTS RESERVED. UNAUTHORIZED REPRODUCTION AND DISTRIBUTION PROHIBITED.

Electrical Information Per Face: 1 (120 Volt/15 Amp circuits. Grounding rod installed per each face, (see Installation Manual.)

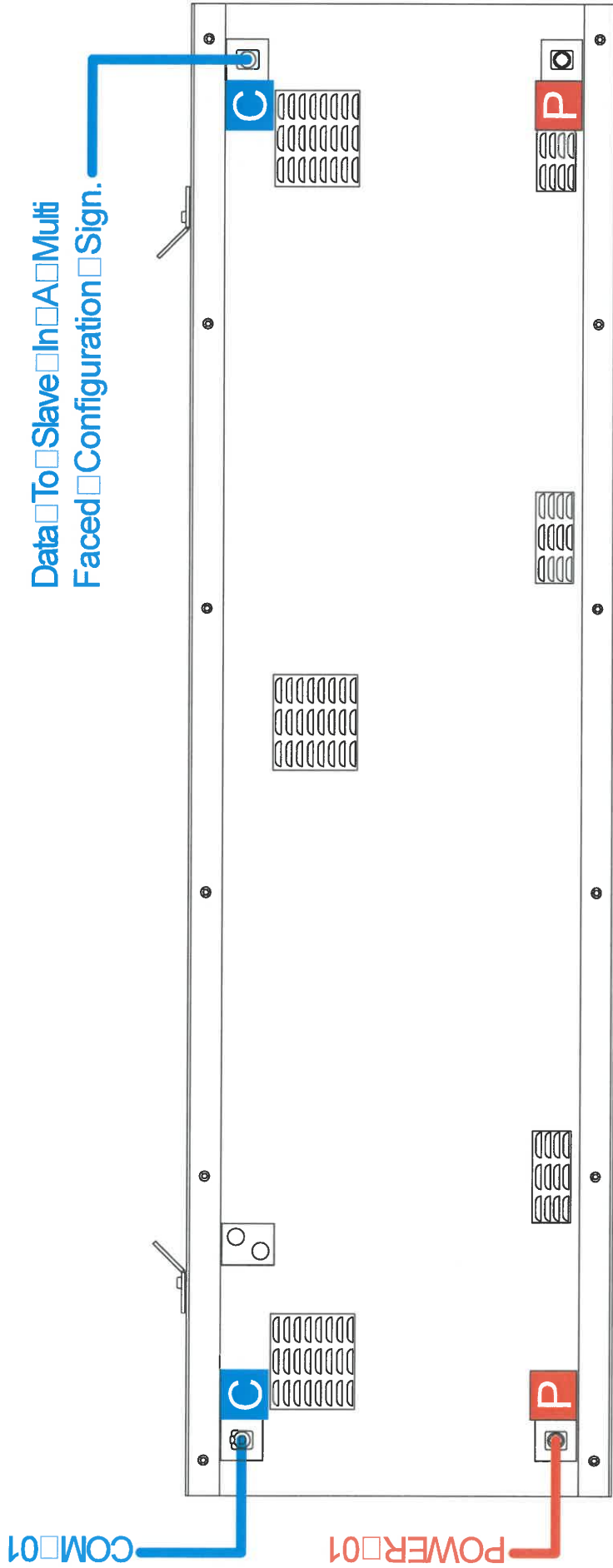

Data To Slave In Multi Faced Configuration Sign.

## BACK VIEW & CIRCUIT SCHEMATIC

MODEL NO: **20mm 030x105**

Version: 2.0 (02/17/2020)

NOTES:

- ( INSTALL PER NATIONAL ELECTRIC CODE
- ( FASTEN USING APPROPRIATELY RATED FASTENERS
- ( DISPLAY IS REAR VENTILATED. DO NOT BLOCK OF SEAL OFF
- ( IMPACTLED IS NOT RESPONSIBLE FOR THE MOUNTING HARDWARE OR THE INTEGRITY OF THE STRUCTURE TO WHICH THE DISPLAY IS MOUNTED.
- ( IMPACT IS NOT RESPONSIBLE FOR THE MAIN POWER DISCONNECT.

Volts: 120  
 Max. Watts: 1250  
 Max. Actual Amps: 5.21  
 Typical Amps: 1.82

WEIGHT: 75 lbs. (per. face)

UNITS: MM (INCH)

COPYRIGHT IMPACT LED SIGNS. ALL RIGHTS RESERVED. UNAUTHORIZED REPRODUCTION AND DISTRIBUTION PROHIBITED.



Notes:





**Sign Location:**

1603 Zion Hill Rd.  
Farmville, VA 23901

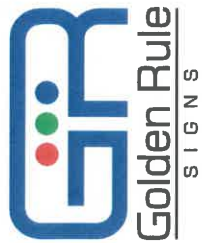

DISREGARD ANY DIMENSIONS AND ART ON THIS PAGE; ONLY USE DIMENSIONS ON LINE DRAWING PAGE AND ART FROM SIGNED ART PAGE.

7'-0"



**SIGN SPECIFICATIONS**

Color: Full Color / RGB text, pictures & video.  
Pitch: 20mm  
Matrix: 30x105  
Dimensions: 2'-0" x 7'-0" (Tall x Wide)  
Max # of Lines: 4  
Max Letter Per Line: 18  
Cabinet Size: 2'-0" x 7'-0" (Tall x Wide)  
Pedestal Size: 4' x 4' (Tall x Wide)



Cabinet PMS Color:  
**PANTONE 2627 C**

Colors used:

CMYK



PMS



Prince Edward High School

VERSION #: R11152201

1482 Zion Hill Rd.  
Farmville, VA 23901



## Scope of Work:

### Electronic Message Center (EMC):

- 20mm, 30 x 105, 2'-0" x 7'-0", Cellular, double
- (4) 2"x2"x1/8" Angle @ 48"
- (4) Side Panel angles

### Fabrication:

- ID Cabinet
- Aluminum stick/extrusion frame, skin painted, 1.5" retainers, 3/16" clear poly-carbonate face, 2nd surface digital print, saddle mount

### Pole Skirt Panels

- (2) Aluminum skin .063", painted, per plan

### Vented Side Panels

- .063" aluminum, painted, routed holes for venting with VHB tape per plan

### Pole Supports w/ Anchor Bolt plates

- Painted per plan

### Structural:

- NA

### Installation:

- Receive and inspect sign from GRS
- Remove and dispose of existing signage
- Mount and attach sign per drawings
- Connect sign to existing power (to be ran by others)

\*\* Take completion photos.\*\*

\*\* Remove and/or level out any excess spoils.\*\*

\*\* Leave a clean job site.\*\*

## Overview:



|  |              |  |      |  |                      |  |             |  |                          |  |                      |  |                   |  |                    |  |            |
|--|--------------|--|------|--|----------------------|--|-------------|--|--------------------------|--|----------------------|--|-------------------|--|--------------------|--|------------|
|  | Double Sided |  | 20mm |  | Anchor Bolt Retrofit |  | GRS Install |  | GRS Remove Existing Sign |  | 120 volts<br>12 amps |  | 4G Cellular Modem |  | Full Depth Cabinet |  | Flat Faces |
|--|--------------|--|------|--|----------------------|--|-------------|--|--------------------------|--|----------------------|--|-------------------|--|--------------------|--|------------|



THE ART ON THIS PAGE IS THE ONLY VERSION OF ART AUTHORIZED TO BE USED FOR PRODUCTION.

\*\*This is visible artwork only and does not account for any bleed or area covered by retainers\*\*



# PRINCE EDWARD COUNTY HIGH SCHOOL

## — UNITED IN EXCELLENCE —

Approved Artwork

Colors used:

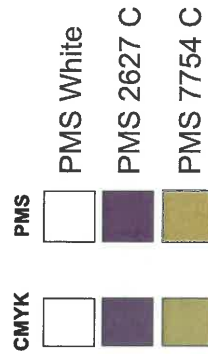

Cabinet PMS Color:  
**PANTONE 2627 C**



Client is responsible for ensuring that the proof is correct in all areas. Double-check spelling, grammar, layout and design before approving artwork. If a proof containing errors is approved by client, the client is responsible for payment of original cost as well as corrections, revisions, and re-makes. This custom artwork is not intended to provide an exact match between ink, vinyl, paint or EMC color. Brickwork, masonry and landscaping is not included in the proposal unless otherwise specifically stated. EMC images shown are simulated. Sign is designed to be illuminated at all times. Sketches are based off of this premise. This is a custom made product, built by hand for people by people. Small blemishes/imperfections may occur and can be expected with hand made products. Industry standard is to view this product from a minimum distance of 10 feet to determine quality acceptability.

Signed Art:



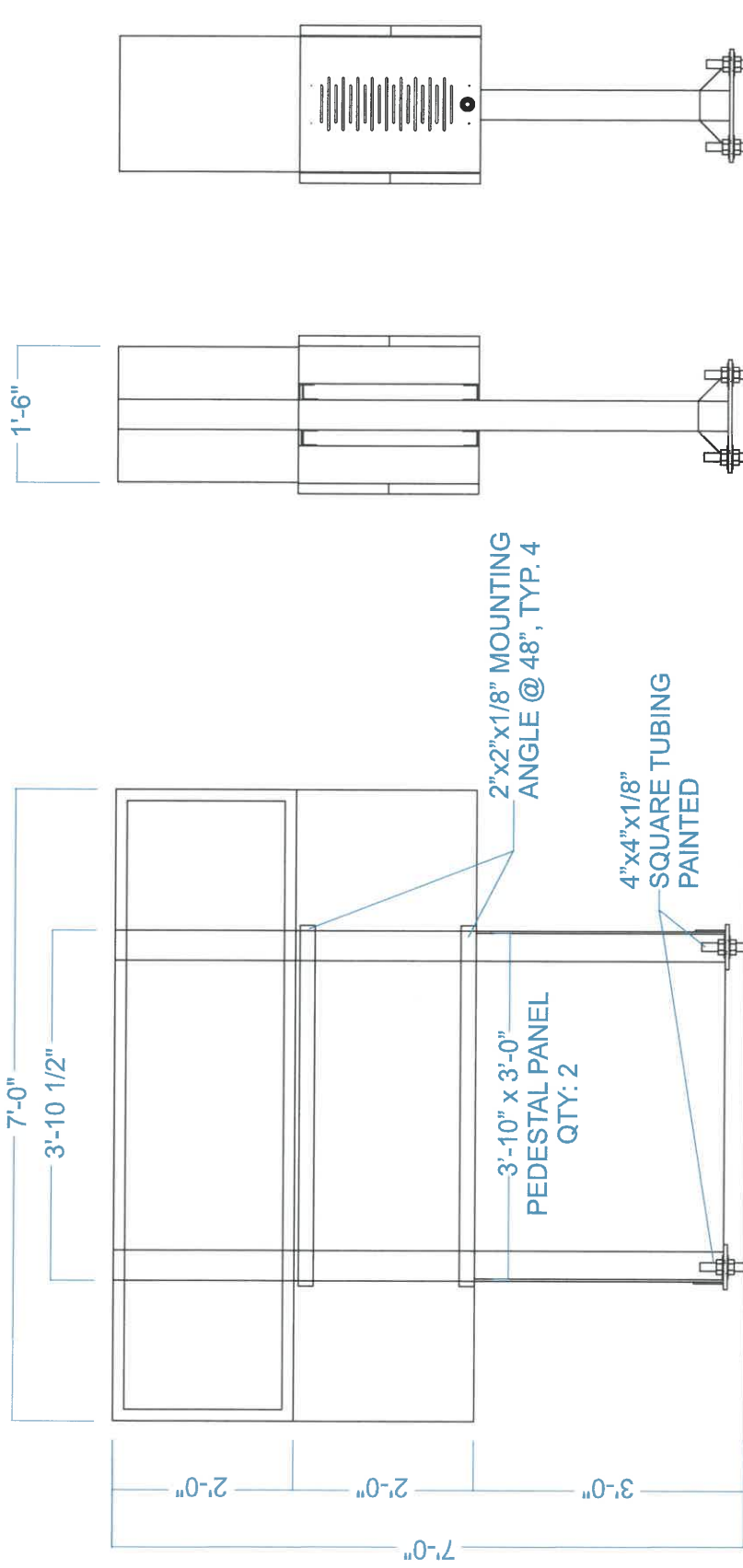

Notes:

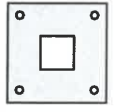

Anchor Bolt Retrofit



Full Depth Cabinet



Double Sided



Notes:

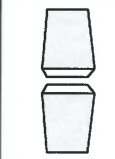

Double Sided



Full Depth Cabinet

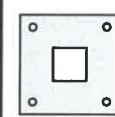

Anchor Bolt Retrofit

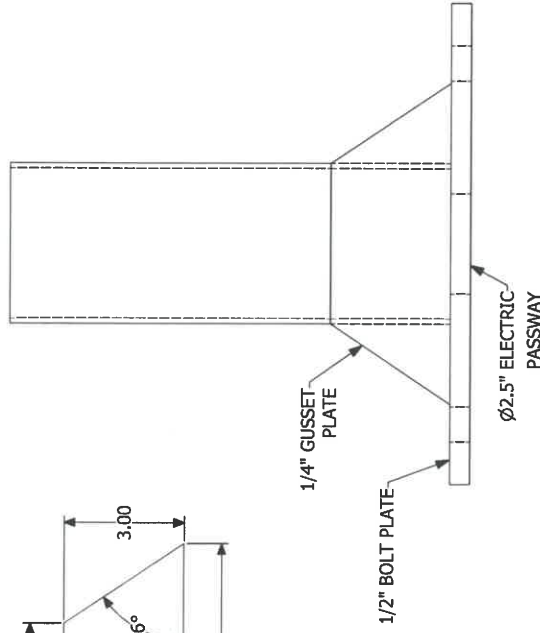
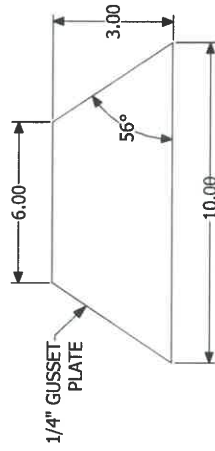
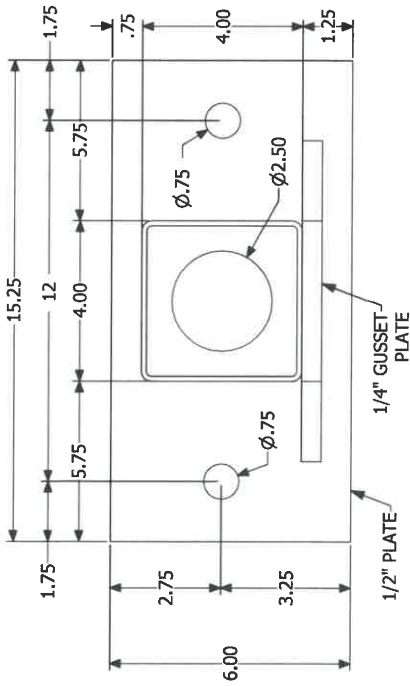
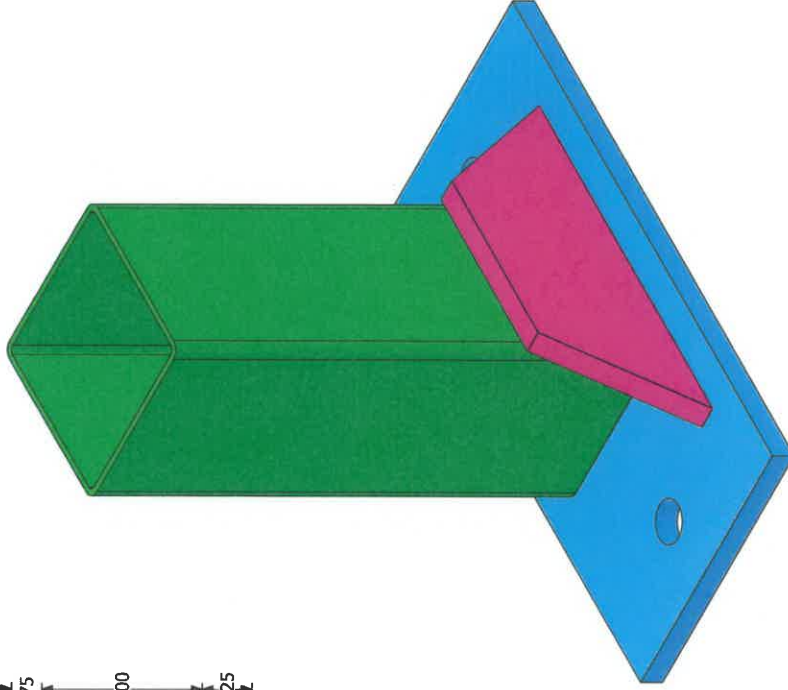

Notes:



Double Sided



Full Depth Cabinet

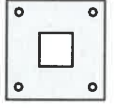

Anchor Bolt Retrofit

Side Panel Angle Length (based on USMB)

- 3" USMB = 7" Side Panel Angles
- 4" USMB = 8" Side Panel Angles**
- 5" USMB = 9" Side Panel Angles
- 6" USMB = 10" Side Panel Angles
- 7" USMB = 11" Side Panel Angles
- 8" USMB = 12" Side Panel Angles

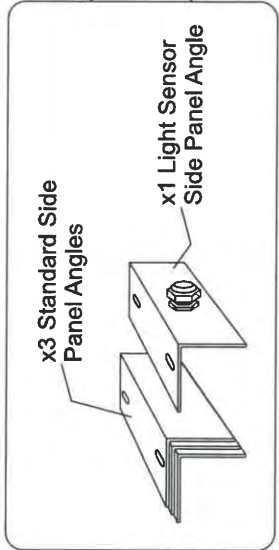

**DO NOT PENETRATE CABINET!**  
Penetrating cabinet will void warranty

\*Top EMC Angles lowered for bolt head clearance & ID Cabinet mounting

Double Sided VHB tape attached to Vented Side Panel

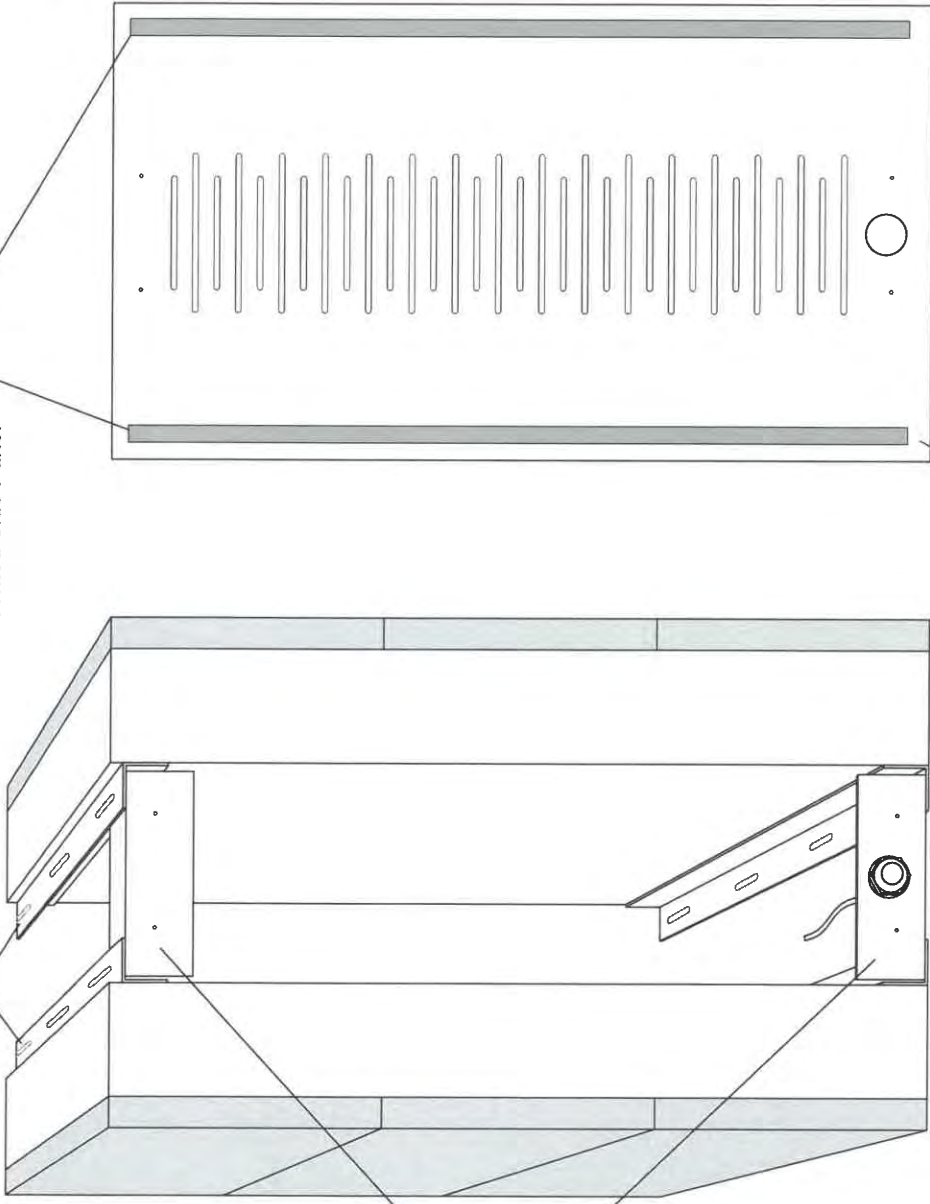

Vented Side Panel secured to Side Panel Angles w/ self tapping screws

**Notes:**

- Set includes:**
- x2 Vented Panels (x1 with light sensor hole)
  - x3 Standard Side Panel Angles
  - x1 Light Sensor & Side Panel Angle



Vented Side Panel Width (based on USMB)

- 3" USMB = 17" Vented Side Panel
- 4" USMB = 18" Vented Side Panel**
- 5" USMB = 19" Vented Side Panel
- 6" USMB = 20" Vented Side Panel
- 7" USMB = 21" Vented Side Panel
- 8" USMB = 22" Vented Side Panel

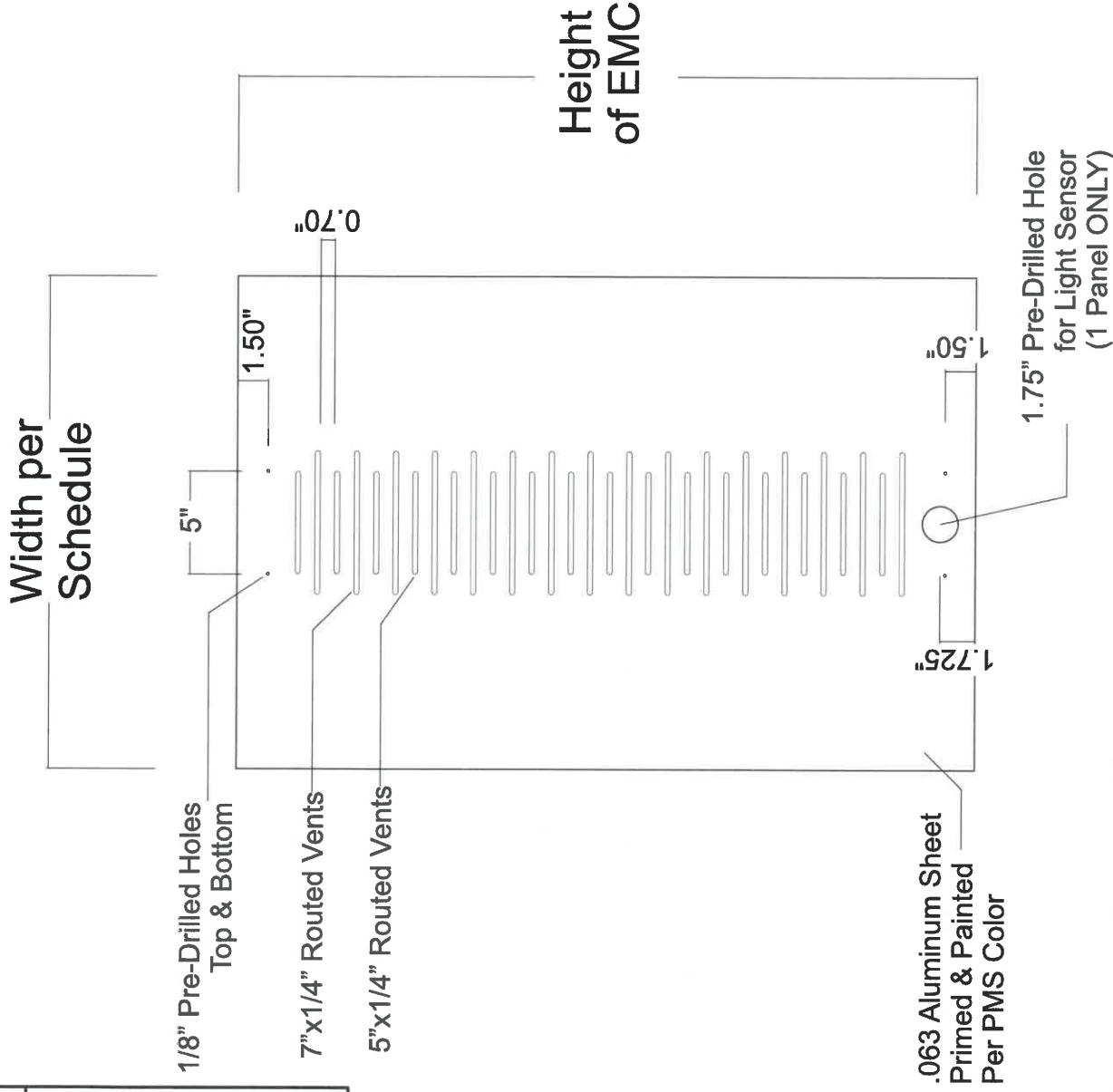

Notes:

- Set includes:**
- x2 Vented Panels (x1 with light sensor hole)
  - x3 Standard Side Panel Angles
  - x1 Light Sensor & Side Panel Angle



Light Sensor Angle Length (based on USMB)

- 3" USMB = 7" Side Panel Angles
- 4" USMB = 8" Side Panel Angles**
- 5" USMB = 9" Side Panel Angles
- 6" USMB = 10" Side Panel Angles
- 7" USMB = 11" Side Panel Angles
- 8" USMB = 12" Side Panel Angles

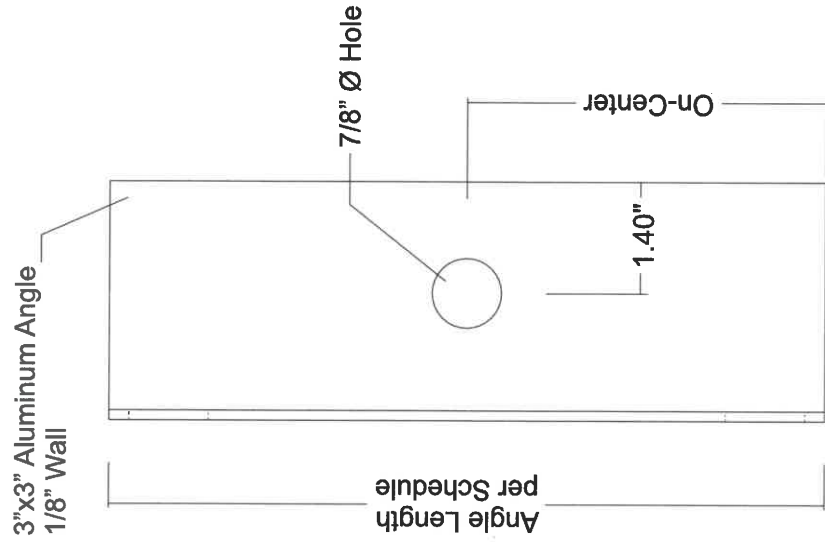
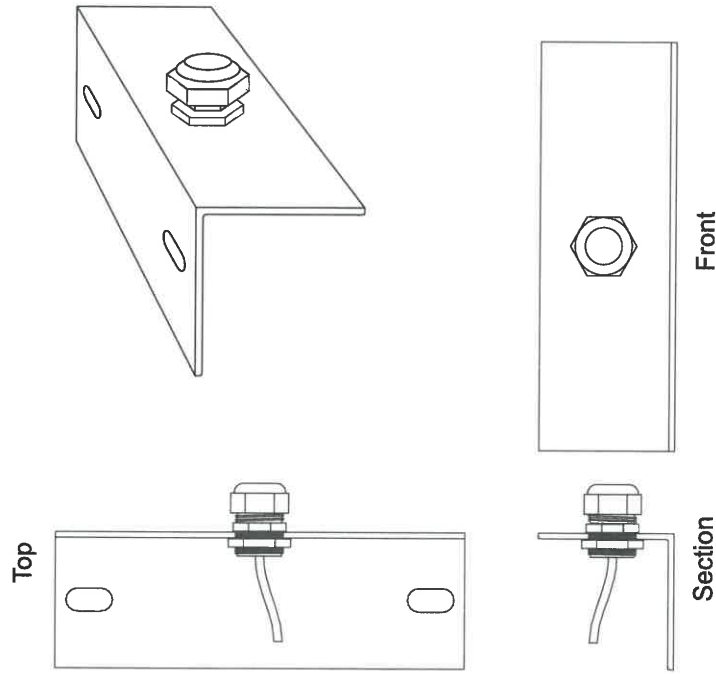

Light Sensor Face

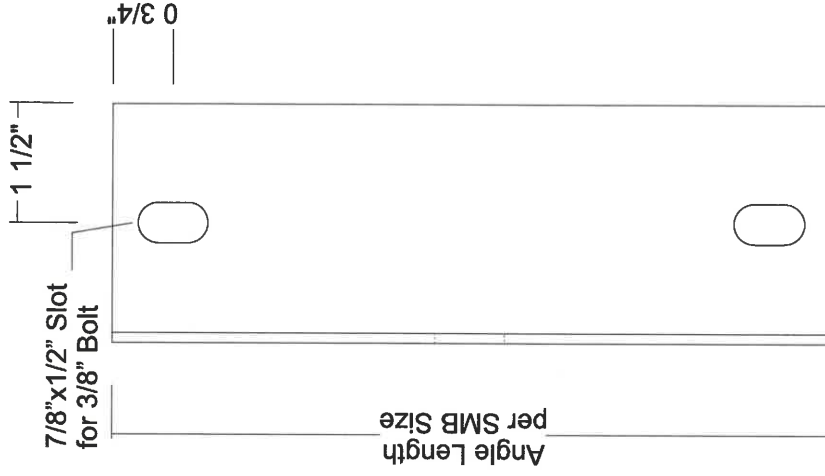

Mounting Face

Notes:

- Set includes:
- x2 Vented Panels (x1 with light sensor hole)
  - x3 Standard Side Panel Angles
  - x1 Light Sensor & Side Panel Angle



\*\*\*All ID Cabinet electrical components to be wide range power to serve up to 240 volts\*\*\*

|                                            |                                 |
|--------------------------------------------|---------------------------------|
| <p><b>120</b> volts<br/><b>12</b> amps</p> | <p>Dedicated<br/>Circuit(s)</p> |
|--------------------------------------------|---------------------------------|

National Electric Code requires that lines not exceed 80% load of any one circuit.

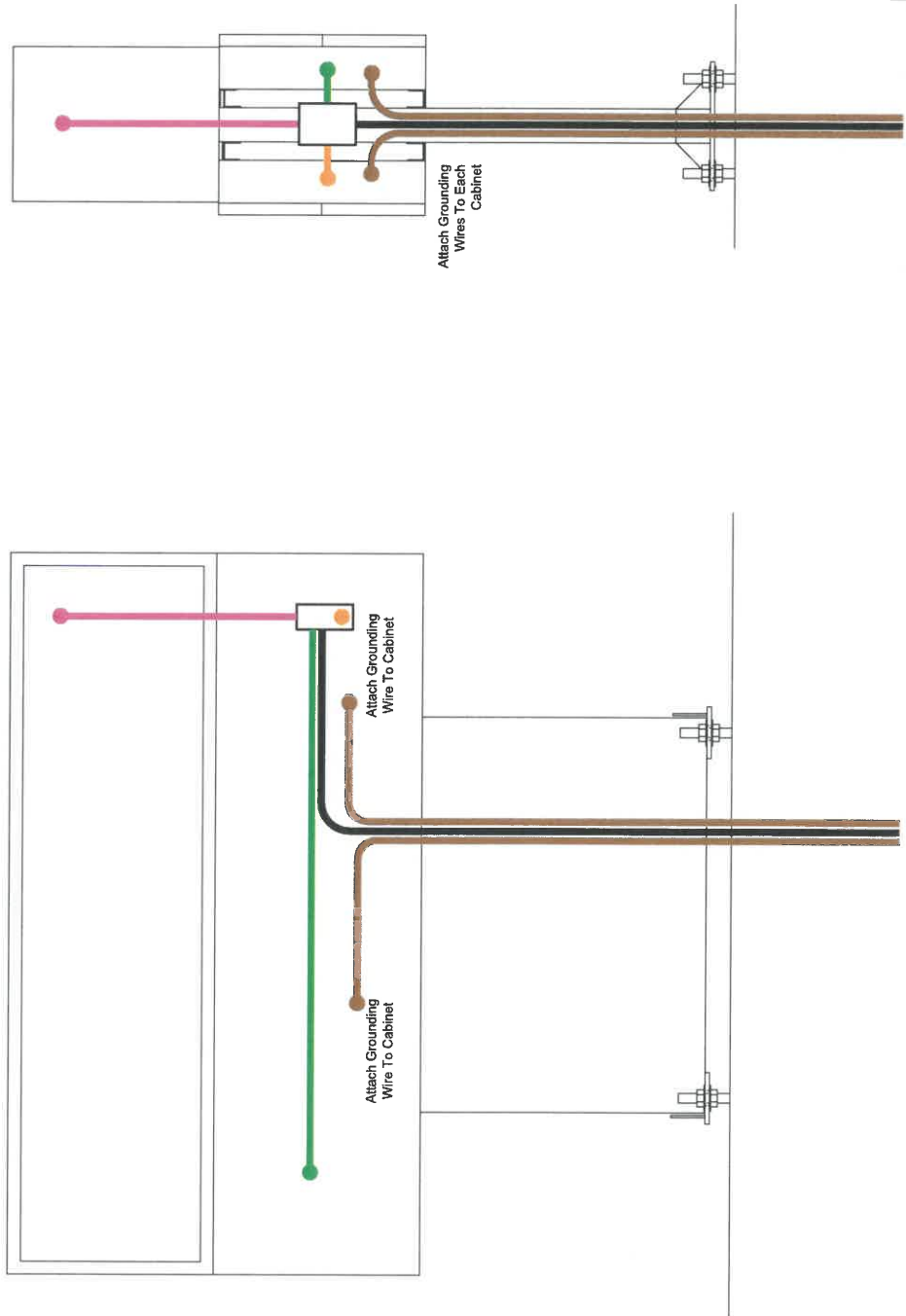

  
**LED  
Installation  
Manual**



**Key:**

- 6GA. COPPER AND 1/2" ROD X6'
- ID CABINET POWER WHIP
- PRIMARY EMC WHIP
- SECONDARY EMC WHIP
- CLIENT PROVIDED PRIMARY

GRS REQUIRES THAT THE SIGN OPERATE ON AT LEAST 1 DEDICATED CIRCUIT AND RECOMMENDS 1 CIRCUIT PER L.E.D. DISPLAY. WARRANTY REQUIRES EACH L.E.D. DISPLAY TO HAVE A MINIMUM 1/2" COPPER, IN-EARTH GROUND ROD WITH CONTINUOUS 6 GAUGE COPPER WIRE, 6' LONG LOCATED 8 FEET FROM THE BASE OF THE SIGN.

  
 Cellular  
Modem

Visit  
[resource.  
impactledsigns.com](http://resource.impactledsigns.com)  
 for more details



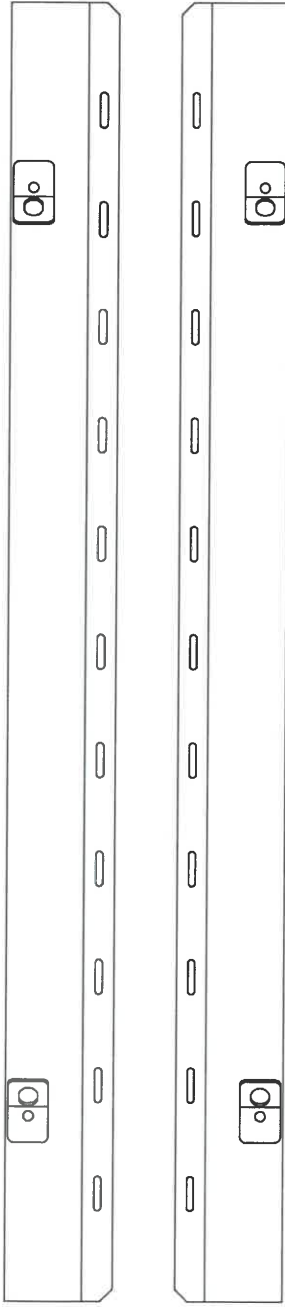

**TOP VIEW**

2134 [84]

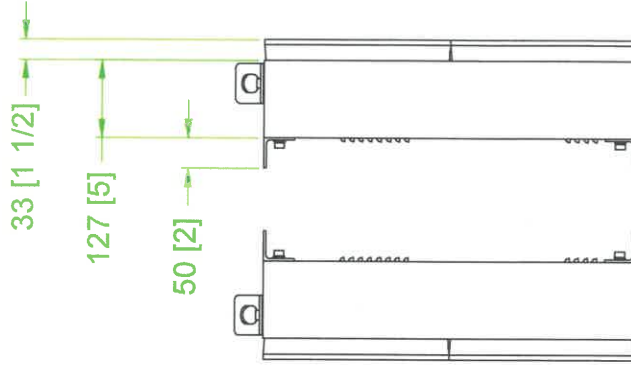

**SIDE VIEW**

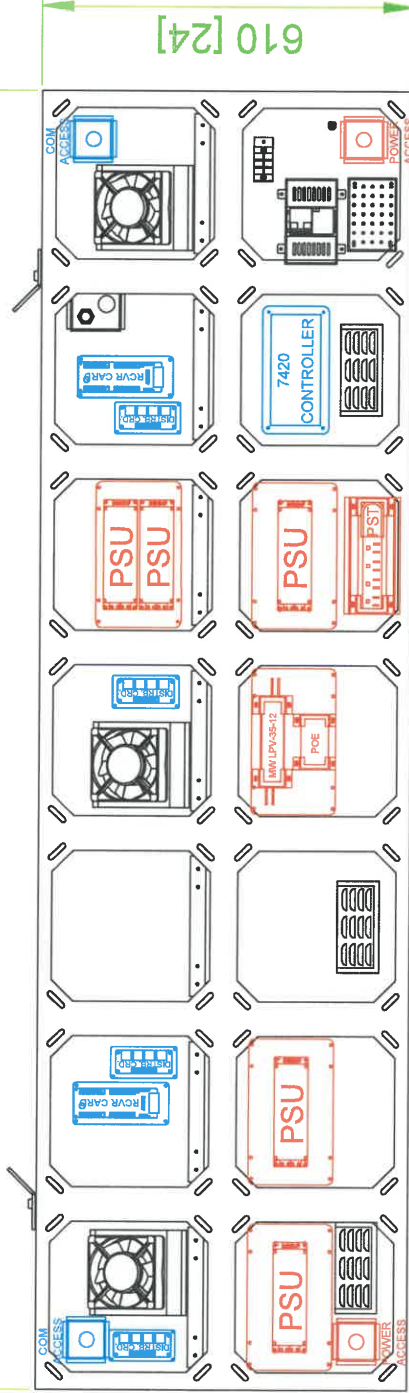

**FRONT VIEW**

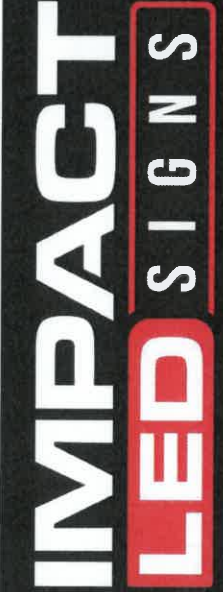

MODEL NO: **20mm 030x105**  
 Version: 2.0 (02/07/2020)

NOTES:  
 1. INSTALL PER NATIONAL ELECTRIC CODE  
 1. FASTEN USING APPROPRIATELY RATED FASTENERS  
 1. DISPLAY IS REAR VENTILATED. DO NOT BLOCK OF SEAL OFF  
 1. IMPACT IS NOT RESPONSIBLE FOR THE MOUNTING HARDWARE OR THE INTEGRITY OF THE STRUCTURE TO WHICH THE DISPLAY IS MOUNTED.  
 1. IMPACT IS NOT RESPONSIBLE FOR THE MAIN POWER DISCONNECT.

Volts: 120  
 Max. Watts: 1250  
 Max. Actual Amps: 5.21  
 Typical Amps: 1.82

WEIGHT:  
 75 lbs.  
 (per face)

UNITS:  
 MM  
 (INCH)

COPYRIGHT. IMPACT LED SIGNS. ALL RIGHTS RESERVED.  
 UNAUTHORIZED REPRODUCTION AND DISTRIBUTION PROHIBITED.

Electrical Information Per Face: 1 (120 Volt/15 Amp circuits. Grounding rod installed per each face, (see Installation Manual.)

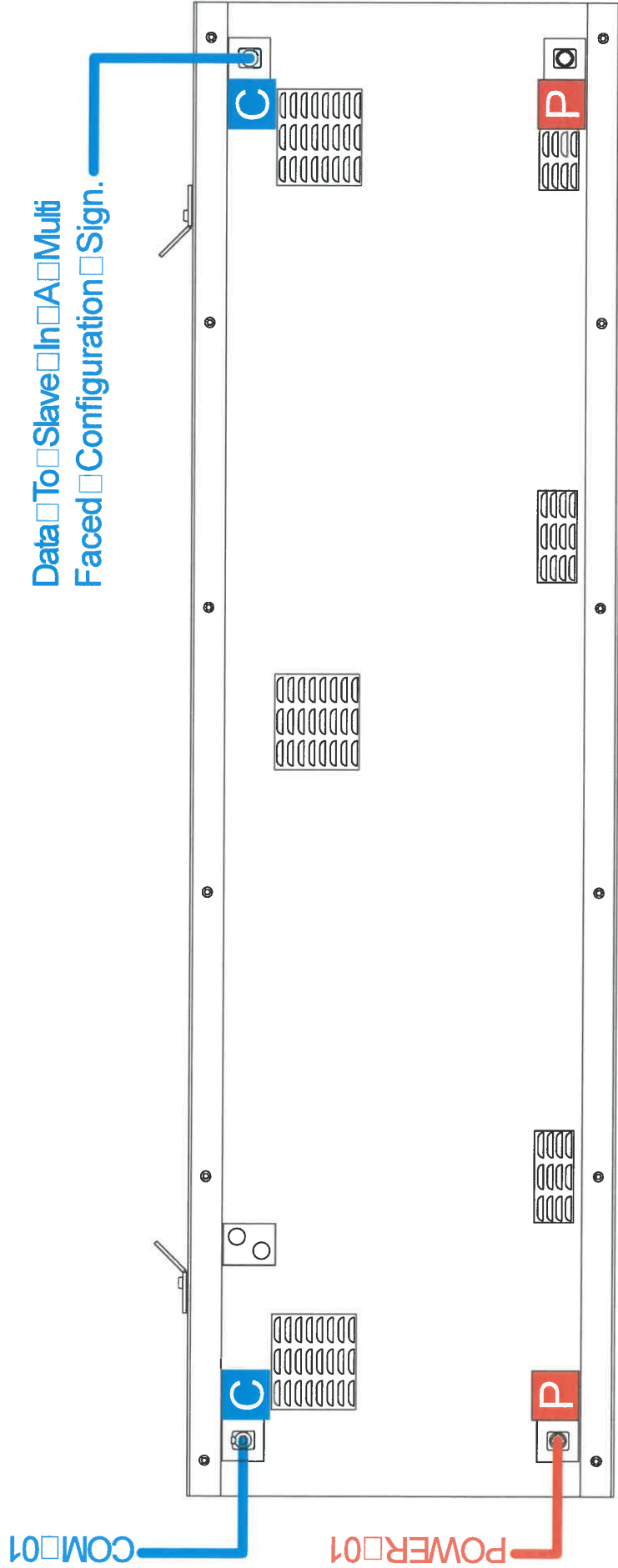

Data To Slave In A Multi Faced Configuration Sign.

## BACK VIEW & CIRCUIT SCHEMATIC



MODEL NO: **20mm 030x105**

Version: 2.0 (02/07/2020)

NOTES:  
 ( INSTALL PER NATIONAL ELECTRIC CODE  
 ( FASTEN USING APPROPRIATELY RATED FASTENERS  
 ( DISPLAY IS REAR VENTILATED. DO NOT BLOCK OF SEAL OFF  
 ( IMPACT IS NOT RESPONSIBLE FOR THE MOUNTING HARDWARE OR  
 THE INTEGRITY OF THE STRUCTURE TO WHICH THE DISPLAY IS MOUNTED.  
 ( IMPACT IS NOT RESPONSIBLE FOR THE MAIN POWER DISCONNECT.

Volts: 120  
 Max. Watts: 1250  
 Max. Actual Amps: 5.21  
 Typical Amps: 1.82

WEIGHT:  
 75 lbs.  
 (per face)

UNITS:  
 MM  
 (INCH)

COPYRIGHT IMPACT LED SIGNS. ALL RIGHTS RESERVED.  
 UNAUTHORIZED REPRODUCTION AND DISTRIBUTION PROHIBITED.



Notes:

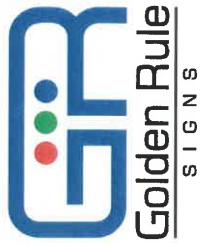



**Sign Location:**

1482 Zion Hill Rd.  
Farmville, VA 23901





## NOTICE OF PUBLIC HEARINGS

The Prince Edward County Board of Supervisors will hold the following **PUBLIC HEARINGS** on Tuesday, May 9, 2023, commencing at 7:30 p.m. in the Board of Supervisors Room, Prince Edward County Courthouse, 111 N. South Street, 3<sup>rd</sup> Floor, Farmville, Virginia, to receive citizen input prior to considering the following:

1. A request by Norvell Signs on behalf of Prince Edward County Public Schools for a Special Use Permit to replace three existing signs at the Prince Edward County Elementary, Middle, and High Schools with electronic signs on Tax Map Parcels 051-8-2 and 051-A-37 on Zion Hill Road, Farmville, VA.
2. Pursuant to Section 15.2-2507 of the *Code of Virginia*, the Board will consider amendments to the FY 23 County Budget and FY 23 County School Budget and accept the distribution of \$949,999.64 of Federal Coronavirus Relief Funds to be appropriated by the Board of Supervisors and distributed to the Prince Edward County Public Schools.

Citizen input for Public Hearings will be received through: (1) in-person participation; (2) remote participation by calling 1-844-890-7777, Access Code # 390313; or (3) by written comments mailed to P.O. Box 382, Farmville, VA 23901; via email to [board@co.prince-edward.va.us](mailto:board@co.prince-edward.va.us); or via facsimile at 434-392-6683. Based on the number of speakers, the Chair will determine the time allotted to each. Citizens may also view the monthly Board of Supervisors meeting live (no public input) at the County's YouTube Channel by using the link on County website under Meetings & Public Notices.

Additional information regarding the special use permit application and the proposed budget amendments is available for public review on the County's web site at [www.co.prince-edward.va.us](http://www.co.prince-edward.va.us) or in the Prince Edward County Administrator's Office, 111 N. South Street, 3<sup>rd</sup> Floor, Farmville, VA. It is the County's intent to comply with the Americans with Disabilities Act. Should you have questions or require special accommodations, please contact the County Administrator's Office at 434-392-8837.

###

Prince Edward County

Special Use Permit

Applicant: Norvell Signs (for PE County Public Schools)

Tax Map: 051-A-37 & 051-8-2

**Schedule B**

List of adjoining Property owners and mailing addresses for the property for 3 electronic signs at each PE County School.

| Parcel ID             | Owner                             | Address                                    | Note |
|-----------------------|-----------------------------------|--------------------------------------------|------|
| 037-A-49              | JOSEPH C. HINES                   | P.O. BOX 268 FARMVILLE, VA<br>23901        |      |
| 038-A-11A             | TOWN OF FARMVILLE                 | P.O. BOX 368 FARMVILLE, VA<br>23901        |      |
| 051-A-38              | ARTHUR & ANNIE MAE WATSON         | 1366 ZION HILL ROAD FARMVILLE, VA<br>23901 |      |
| 051-A-36B;<br>051-8-1 | PRINCE EDWARD COUNTY SCHOOL BOARD | 35 EAGLE DRIVE FARMVILLE,<br>VA 23901      |      |
| 051-A-36A             | ANDREWS LARGE AND WHIDDEN INC     | P.O. BOX 527 FARMVILLE, VA<br>23901        |      |
|                       |                                   |                                            |      |
|                       |                                   |                                            |      |
|                       |                                   |                                            |      |
|                       |                                   |                                            |      |
|                       |                                   |                                            |      |
|                       |                                   |                                            |      |
|                       |                                   |                                            |      |
|                       |                                   |                                            |      |
|                       |                                   |                                            |      |
|                       |                                   |                                            |      |
|                       |                                   |                                            |      |
|                       |                                   |                                            |      |
|                       |                                   |                                            |      |
|                       |                                   |                                            |      |
|                       |                                   |                                            |      |

**BOARD OF SUPERVISORS**

Llew W. Gilliam, Jr.  
Chair

Pattie Cooper-Jones  
Vice Chair

J. David Emert  
Victor "Bill" Jenkins  
E. Harrison Jones  
Odessa H. Pride, Ed.D.  
Jerry R. Townsend  
B. VonCannon Watson



**COUNTY OF PRINCE EDWARD, VIRGINIA**

**Director of Planning and  
Community Development**

Robert Love

Post Office Box 382  
111 N. South Street, 3<sup>rd</sup> Floor  
Farmville, VA 23901

Office: (434) 414-3037  
Fax: (434) 392-6683

[rlove@co.prince-edward.va.us](mailto:rlove@co.prince-edward.va.us)  
[www.co.prince-edward.va.us](http://www.co.prince-edward.va.us)

April 25, 2023

To: Property Owners

From: Robert Love, Director of Planning and Community Development

Subject: Special Use Permit Request – Norvell Signs

The Prince Edward County Board of Supervisors will hold a public hearing on Tuesday, May 9, 2023 at 7:30 p.m. to receive citizen input on a request by Norvell Signs on behalf of Prince Edward County Public Schools for a Special Use Permit to replace three existing signs at the Prince Edward County Elementary, Middle, and High Schools with electronic signs on Tax Map Parcels 051-8-2 and 051-A-37 on Zion Hill Road, Farmville, VA. The parcel is zoned A-2, Agricultural Residential and the proposed use requires approval of a Special Use Permit in this zoning district.

You are receiving this notice because you own land in the vicinity of the property requested to be approved for the special use permit. Following the hearing the Prince Edward County Board of Supervisors may vote to approve or deny the request.

Instructions of how to listen or participate in the meeting and public hearing are contained on the reverse side of this letter. If you have any questions or comments, please do not hesitate to contact me at: 434-414-3037 or by email at: [rlove@co.prince-edward.va.us](mailto:rlove@co.prince-edward.va.us)

Respectfully,

Robert Love

Director of Planning and Community Development

**BOARD OF SUPERVISORS**

Llew W. Gilliam, Jr.  
Chair

Pattie Cooper-Jones  
Vice Chair

J. David Emert  
Victor "Bill" Jenkins  
E. Harrison Jones  
Odessa H. Pride, Ed.D.  
Jerry R. Townsend  
B. VonCannon Watson



**COUNTY OF PRINCE EDWARD, VIRGINIA**

**Director of Planning and  
Community Development**

Robert Love

Post Office Box 382  
111 N. South Street, 3<sup>rd</sup> Floor  
Farmville, VA 23901

Office: (434) 392-8837  
Fax: (434) 392-6683

[rlove@co.prince-edward.va.us](mailto:rlove@co.prince-edward.va.us)  
[www.co.prince-edward.va.us](http://www.co.prince-edward.va.us)

April 25, 2023

C. Scott Davis, Town Manager  
Town of Farmville, Virginia  
P.O. Box 368  
Farmville, VA 23901

From: Robert Love, Director of Planning and Community Development

Subject: Special Use Permit – Norvell Signs for Prince Edward County Public Schools

Dear Mr. Davis;

Per §15.2-2204 (C) of the Code of Virginia (1950), as amended, you are being sent written notification of a Special Use Permit application as listed in the attached public notice which involves a parcel of land within one-half mile of a boundary with an adjoining locality.

The Prince Edward Board of Supervisors will hold a public hearing on Tuesday, May 9, 2023 at 7:30 p.m. to receive input on the requests. Instructions of how to listen or participate in the meeting and public hearing are contained on the reverse side of this letter.

If you have any questions or comments, please forward them to my attention no later than noon on the date of the public meeting. please do not hesitate to contact me at: 434-414-3037 or by email at: [rlove@co.prince-edward.va.us](mailto:rlove@co.prince-edward.va.us)

Respectfully,

Robert Love

Director of Planning and Community Development



# Norvell Signs SUP Tax Map #'s 051-8-2 & 051-A-37



April 11, 2023

- Road Centerline
- ▭ County Boundary
- ▭ Parcel Labels
- ▭ Farmville Boundary

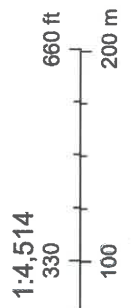

1:4,514  
Virginia Geographic Information Network (VGIN)

Special Use Permit – Norvell Signs  
Tax Parcel Map #: 05-8-2 and 051-A-37  
POTENTIAL CONDITIONS

**SITE PLAN**

1. Development activities on the site shall be limited to those as specified in the Special Use Permit Application and Site Plan. The final locations of facilities may be adjusted provided no such adjustment violates any buffers, setbacks, or other statutory requirement. The concepts reflected in the filed special use permit dated 3/16/2023 are hereby made part of these development conditions.
2. Final sign permit zoning and building permit applications for the three (3) electronic signs shall be submitted to the Planning and Community Development office for final review and approval pursuant to Appendix B of the Prince Edward County Code (Zoning) and Chapter 18 of the Prince Edward County Code (Buildings and Building Regulations).

**GENERAL**

3. All landscaping around signs shall be mulched and maintained to the reasonable satisfaction of the Prince Edward County Planning and Community Development Director. Any vegetation found to be of poor condition shall be replaced and/or improved at the reasonable direction of the Planning and Community Development Director or his designee.
4. No sign shall be may be located within VDOT right-of-way or impede sight distance.
5. Site signage shall be limited to Freestanding type, as specified in Appendix B – Zoning, 2-1300.5(H)(3).
6. Sign installation shall be in conformance with all applicable provisions of federal, state, and local statues and regulations.
7. Any sign lighting shall be designed and installed so as to minimize glare onto adjoining properties or any public access road.
8. This Permit is non-transferable, except and unless written notice from the Permittee regarding the transfer, and a signed document from the proposed new Permittee is received by the Planning and Community Development Office which states that the new Permittee agrees to comply with all terms and Conditions imposed with the original Permit Issuance. If the proposed new Permittee desires to amend the original Permit Conditions, amendments must be addressed by the Prince Edward County Planning Commission and Board of Supervisors through the Special Use Permit process.
9. Failure of Permittee to full conform to all terms and conditions may result in revocation of this Special Use Permit if said failure or failures are not corrected or addressed to the satisfaction, not to be unreasonably withheld, of the County within thirty (30) days of written notice from the County.

The following is an excerpt of the draft minutes of the regular meeting of the Prince Edward County Planning Commission held April 20, 2023.

**In Re: Public Hearing – Special Use Permit, Norvell Signs**

Vice Chairman Peery announced this was the date and time scheduled to receive citizen input prior to considering a request from Norvell Signs for a Special Use Permit on behalf of Prince Edward County Public Schools to replace three existing signs at the Prince Edward County Elementary, Middle, and High Schools with electronic signs on Tax Map Parcels 051-8-2 and 051-A-37 on Zion Hill Road, Farmville, Virginia. Notice of this hearing was advertised according to law in the Wednesday, April 5, 2023 and Wednesday, April 12, 2023 editions of THE FARMVILLE HERALD, a newspaper published in the County of Prince Edward.

Mr. Love stated the County has received an application for a Special Use Permit from Norvell Signs on behalf of Prince Edward County Public Schools to replace three existing signs at the Prince Edward County Elementary, Middle, and High Schools with electronic signs on Tax Map Parcels 051-8-2 and 051-A-37 on Zion Hill Road, Farmville, VA. These parcels are zoned A-2, Agricultural Residential and electronic signs require approval of a Special Use Permit.

The purpose of the Special Use is to allow for the installation of three electronic signs to replace the existing signs, one at each school facility. The Elementary School site is within the Highway Corridor Overlay District with a provision for signage not exceeding 30 square feet on each face. The Middle School and High School are outside of the HCO but are subject to A-2 Zoning District sign standards. For consistency in design, each sign is of similar construction, with a sign face of 28 square feet and an overall height of 7'-0". The proposed signs meet both the Highway Corridor Overlay (HCO) District and the A-2 District requirements.

Dwayne Norvell, Norvell Signs, stated they will meet all standards and conditions.

Vice Chairman Peery opened the public hearing.

Commissioner Gilliam asked if the remodeling that will be done at the Elementary School will have any effect on this sign and its placement.

Mr. Norvell stated these signs are on a bolt-installation system; he said they can be unbolted from the concrete pad and are able to be easily moved.

Commissioner Fuller asked if there is anything in the County Code that would restrict the illumination of the sign. Mr. Love stated that the Conditions state that any sign lighting shall be designed and installed to minimize glare onto adjoining properties or any public access road. He said the lumens would have to be adjusted.

Mr. Norvell said the signs are programmable to set dimming; he added there is a photocell in them that would automatically dim the light when it is very dark and gets brighter in the daylight.

Commissioner Gilliam stated there was an issue with a fire department's sign that scared an Amish people's horse and they had to calm the horse.

Commissioner Womack added the Amish people's horses have issues with flashing lights.

There being no one further wishing to speak, Chairman Prengaman closed the public hearing.

Vice Chairman Peery asked the Commissioners to review the potential conditions.

Commissioner Fuller made a motion, seconded by Commissioner Paige, to recommend to the Board of Supervisors approval of the Special Use Permit request by Norvell Signs to replace the existing signs at the Prince Edward County Elementary, Middle, and High Schools with electronic signs with the following conditions; the motion carried:

|      |                      |      |        |
|------|----------------------|------|--------|
| Aye: | Brad Fuller          | Nay: | (None) |
|      | Llew W. Gilliam, Jr. |      |        |
|      | Preston Hunt         |      |        |

Clifford Jack Leatherwood

Whitfield M. Paige

John "Jack" W. Peery, Jr.

Teresa Sandlin

Henry Womack

Absent: John Prengaman

Rhett Weiss

Special Use Permit – Norvell Signs  
Tax Parcel Map #: 05-8-2 and 051-A-37  
POTENTIAL CONDITIONS

**SITE PLAN**

1. Development activities on the site shall be limited to those as specified in the Special Use Permit Application and Site Plan. The final locations of facilities may be adjusted provided no such adjustment violates any buffers, setbacks, or other statutory requirement. The concepts reflected in the filed special use permit dated 3/16/2023 are hereby made part of these development conditions.
2. Final sign permit zoning and building permit applications for the three (3) electronic signs shall be submitted to the Planning and Community Development office for final review and approval pursuant to Appendix B of the Prince Edward County Code (Zoning) and Chapter 18 of the Prince Edward County Code (Buildings and Building Regulations).

**GENERAL**

3. All landscaping around signs shall be mulched and maintained to the reasonable satisfaction of the Prince Edward County Planning and Community Development Director. Any vegetation found to be of poor condition shall be replaced and/or improved at the reasonable direction of the Planning and Community Development Director or his designee.
4. No sign shall be may be located within VDOT right-of-way or impede sight distance.
5. Site signage shall be limited to Freestanding type, as specified in Appendix B – Zoning, 2.1300.5(H)(3).
6. Sign installation shall be in conformance with all applicable provisions of federal, state, and local statues and regulations.
7. Any sign lighting shall be designed and installed so as to minimize glare onto adjoining properties or any public access road.
8. This Permit is non-transferable, except and unless written notice from the Permittee regarding the transfer, and a signed document from the proposed new Permittee is received by the Planning and Community Development Office which states that the new Permittee agrees to comply with all terms and Conditions imposed with the original Permit Issuance. If the proposed new Permittee desires to amend the original Permit Conditions, amendments must be addressed by the Prince Edward County Planning Commission and Board of Supervisors through the Special Use Permit process.
9. Failure of Permittee to full conform to all terms and conditions may result in revocation of this Special Use Permit if said failure or failures are not corrected or addressed to the satisfaction, not to be unreasonably withheld, of the County within thirty (30) days of written notice from the County.



**Board of Supervisors  
Agenda Summary**

**Meeting Date:** May 9, 2023  
**Item #:** 11-b  
**Department:** Finance/HR  
**Staff Contact:** Cheryl Stimpson  
**Agenda Item:** PUBLIC HEARING: School CARES ACT Budget

---

**Summary:** As the Board is aware, the Prince Edward County Public Schools has received a total of \$949,999.64 of additional CARES Act funds for the 2022-2023 school year.

Prior to the expenditure and in accordance with 15.2-2507 of the *Code of Virginia*, the Board will hold a public hearing to increase the FY23 County and School Budgets, accepting the distribution of federal funds and appropriate the funding to the FY23 County and School Budgets.

Attached is a copy of the School’s Request for Appropriation of Additional Funds that represents the plan of expenditures.

**Attachments:** Public Hearing Notice  
School Letter

**Recommendation:** Following the public hearing, the Board will wish to increase the FY23 County Budget and FY23 School Budget by \$949,999.64 and appropriate the same funds to enable the expenditure of the CARES ACT funds.

**SAMPLE MOTION: I MOVE THAT THE BOARD OF SUPERVISORS APPROVE THE BUDGET SUPPLEMENT REQUEST AND APPROPRIATE THE SAME FUNDS.**

Motion \_\_\_\_\_ Cooper-Jones \_\_\_\_\_ Gilliam \_\_\_\_\_ Pride \_\_\_\_\_  
Second \_\_\_\_\_ Emert \_\_\_\_\_ Jenkins \_\_\_\_\_ Townsend \_\_\_\_\_  
Jones \_\_\_\_\_ Watson \_\_\_\_\_



## NOTICE OF PUBLIC HEARINGS

The Prince Edward County Board of Supervisors will hold the following **PUBLIC HEARINGS** on **Tuesday, May 9, 2023**, commencing at 7:30 p.m. in the Board of Supervisors Room, Prince Edward County Courthouse, 111 N. South Street, 3rd Floor, Farmville, Virginia, to receive citizen input prior to considering the following:

1. A request by Norvell Signs on behalf of Prince Edward County Public Schools for a Special Use Permit to replace three existing signs at the Prince Edward County Elementary, Middle, and High Schools with electronic signs on Tax Map Parcels 051-8-2 and 051-A-37 on Zion Hill Road, Farmville, VA.
2. Pursuant to Section 15.2-2507 of the Code of Virginia, the Board will consider amendments to the FY 23 County Budget and FY 23 County School Budget and accept the distribution of \$949,999.64 of Federal Coronavirus Relief Funds to be appropriated by the Board of Supervisors and distributed to the Prince Edward County Public Schools.

Citizen input for Public Hearings will be received through: (1) in-person participation; (2) remote participation by calling 1-844-890-7777, Access Code # 390313; or (3) by written comments mailed to P.O. Box 382, Farmville, VA 23901; via email to [board@co.prince-edward.va.us](mailto:board@co.prince-edward.va.us); or via facsimile at 434-392-6683. Based on the number of speakers, the Chair will determine the time allotted to each. Citizens may also view the monthly Board of Supervisors meeting live (no public input) at the County's YouTube Channel by using the link on County website under Meetings & Public Notices.

Additional information regarding the special use permit application and the proposed budget amendments is available for public review on the County's web site at [www.co.prince-edward.va.us](http://www.co.prince-edward.va.us) or in the Prince Edward County Administrator's Office, 111 N. South Street, 3rd Floor, Farmville, VA. It is the County's intent to comply with the Americans with Disabilities Act. Should you have questions or require special accommodations, please contact the County Administrator's Office at 434-392-8837.

**PRINCE EDWARD COUNTY  
PUBLIC SCHOOLS**

**Barbara A. Johnson, Ed. D**

*Superintendent*

March 8, 2023

Prince Edward County  
Mr. Doug Stanley, County Administrator  
P. O. Box 382  
Farmville, VA 23901

Dear Mr. Stanley:

The Prince Edward County School Board respectfully requests an appropriation of funds in the amount of \$949,999.64 to the CARES ACT budget for the 2022-2023 school year. The additional amount requested will represent a total of \$2,587,307.97 in the Cares Act FY2022-2023 budget. There is no local match required for this appropriation.

Thank you for your consideration of this request.

Respectfully submitted,

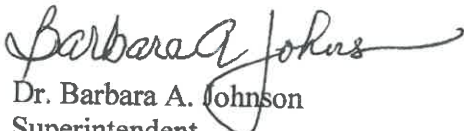
  
Dr. Barbara A. Johnson  
Superintendent

  
Mrs. Lucy Carson  
Chairperson, School Board

BAJ/vmj

pc: School Board Members

---

**UNITED IN EXCELLENCE**

---

35 Eagle Drive Farmville, VA 23901 | Telephone: 434-315-2150 | Fax: 434-392-1911

**Action Item 11A: Cares Act Funds**

**Subject:** Request of Appropriation of Additional Funds

**Recommendation:** It is recommended that the School Board request from the Prince Edward County Board of Supervisors carry-over funds from the FY2021-2022 school year in the amount of \$949,999.64 to the CARES ACT Budget for FY2022-2023 school year.

**Increase:** \$688,257.05 – Carry-Over Appropriation from FY2021-2022 – ESSER II-CRRSA (Cares Act Funding)

**Increase:** \$8,918.00 – Carry-Over Appropriation from FY2021-2022 – ESSER III-ARP-Teal (Cares Act Funding)

**Increase:** \$1,145.80 – Carry-Over Appropriation from FY2021-2022 – ESSER III-Before and After (Cares Act Funding)

**Increase:** \$251,678.79 – Carry-Over Appropriation from FY2021-2022 – ESSER III-Unfinished Learning (Cares Act Funding)

**Rationale:** Prince Edward County Public Schools is requesting that carry-over from FY2021-2022 in the amount of \$949,999.64 be appropriated to the Cares Act Budget for the FY2022-2023 school year.

**Budget:** Revenues  
Expenditure

**Legal Reference:** Prince Edward County School Board Policies  
DA – Management of Funds  
DB – Annual Budget





Online Management of Education Grant Awards (OMEGA)

- OMEGA SUPPORT
- HELP
- PRINT
- LOGOUT

Current User: Amy McClure

Current Subrecipient: 00073 - PRINCE EDWARD CO PBLC SCHS

I want to... (Select One) Go

[SSWS Home](#)

[OMEGA Home](#)

[Logout](#)

### Spend Down Report

Selected Project Group, Project, Award Information

Project Group: CRRSA ESSER II

Project: APE50195, CRRSA ESSER II

Award: S425D210008 Award Year:2021

Payee: PRINCE EDWARD CO PBLC SCHS

| Date       | Description     | Status            | Major Objects |             |            |              |            |          |             | Total      |              |
|------------|-----------------|-------------------|---------------|-------------|------------|--------------|------------|----------|-------------|------------|--------------|
|            |                 |                   | 0000          | 1000        | 2000       | 3000         | 4000       | 5000     | 6000        |            | 8000         |
| 03/01/2021 | Original Budget |                   | 3,143,231.00  | 0.00        | 0.00       | 0.00         | 0.00       | 0.00     | 0.00        | 0.00       | 3,143,231.00 |
| 10/25/2021 | Budget 410631   | Transfer Complete | -3,143,231.00 | 343,214.00  | 84,302.75  | 1,856,258.26 | 70,000.00  | 6,000.00 | 783,455.99  | 0.00       | 0.00         |
| 12/24/2021 | Reimb 413565    | Paid              | 0.00          | -8,487.72   | -2,010.75  | 0.00         | 0.00       | 0.00     | 0.00        | 0.00       | -10,498.47   |
| 01/17/2022 | Reimb 411598    | Paid              | 0.00          | -36,736.44  | -7,093.81  | -147,997.09  | 0.00       | 0.00     | -272,524.00 | 0.00       | -464,351.34  |
| 01/28/2022 | Reimb 417377    | Paid              | 0.00          | 0.00        | 0.00       | -17,870.00   | 0.00       | 0.00     | -24,757.61  | 0.00       | -42,627.61   |
| 02/18/2022 | Reimb 421129    | Paid              | 0.00          | -46,386.18  | -11,794.50 | -8,995.00    | 0.00       | 0.00     | -172,362.50 | 0.00       | -239,538.18  |
| 04/08/2022 | Reimb 425549    | Paid              | 0.00          | -7,535.03   | -2,005.23  | 0.00         | 0.00       | 0.00     | -1,236.95   | 0.00       | -10,777.21   |
| 05/20/2022 | Reimb 429562    | Paid              | 0.00          | -30,337.53  | -3,744.06  | 0.00         | 0.00       | 0.00     | -1,104.00   | 0.00       | -35,185.59   |
| 08/23/2022 | Budget 442288   | Transfer Complete | 0.00          | 491,469.29  | 37,597.41  | -715,463.82  | 0.00       | 0.00     | 186,397.12  | 0.00       | 0.00         |
| 08/26/2022 | Reimb 422764    | Paid              | 0.00          | -7,612.73   | -2,005.61  | 0.00         | 0.00       | 0.00     | 0.00        | 0.00       | -9,618.34    |
| 09/30/2022 | Reimb 444494    | Paid              | 0.00          | 0.00        | 0.00       | -4,649.34    | 0.00       | 0.00     | 0.00        | 0.00       | -4,649.34    |
| 09/30/2022 | Reimb 444537    | Paid              | 0.00          | 0.00        | 0.00       | -106,600.94  | 0.00       | 0.00     | -42,195.17  | 0.00       | -148,796.11  |
| 11/18/2022 | Reimb 452632    | Paid              | 0.00          | -120,190.95 | -16,026.68 | -115,316.33  | 0.00       | 0.00     | 0.00        | 0.00       | -251,533.96  |
| 12/09/2022 | Reimb 454258    | Paid              | 0.00          | 0.00        | 0.00       | -19,827.00   | 0.00       | 0.00     | -239.16     | 0.00       | -20,066.16   |
| 02/24/2023 | Reimb 459941    | Paid              | 0.00          | -7,435.20   | -1,996.12  | 0.00         | 0.00       | 0.00     | 0.00        | 0.00       | -9,431.32    |
| 03/03/2023 | Reimb 459555    | Paid              | 0.00          | 0.00        | 0.00       | -12,298.00   | 0.00       | 0.00     | -2,696.29   | 0.00       | -14,994.29   |
| 03/12/2023 | Budget 462030   | Transfer Complete | 0.00          | -61,702.00  | -20,700.00 | -541,798.54  | -20,000.00 | 0.00     | 47,301.87   | 596,898.67 | 0.00         |
| 03/24/2023 | Reimb 462753    | Paid              | 0.00          | -218,574.68 | -18,072.30 | 0.00         | 0.00       | 0.00     | 0.00        | 0.00       | -236,646.98  |
|            | Current Balance |                   | 0.00          | 289,684.83  | 36,451.10  | 165,442.20   | 50,000.00  | 6,000.00 | 500,039.30  | 596,898.67 | 1,644,516.10 |

Spend Down Calendar

| Target Date | Target Expenditures | Calculated Expenditures | Difference | Target Percentage | Calculated Percentage | Difference |
|-------------|---------------------|-------------------------|------------|-------------------|-----------------------|------------|
|-------------|---------------------|-------------------------|------------|-------------------|-----------------------|------------|

[Back](#)



Online Management of Education Grant Awards (OMEGA)

- OMEGA SUPPORT
- HELP
- PRINT
- LOGOUT

Current User: Amy McClure

Current Subrecipient: 00073 - PRINCE EDWARD CO PBLC SCHS

I want to... (Select One) Go

[SSWS Home](#)

[OMEGA Home](#)

[Logout](#)

### Spend Down Report

Selected Project Group, Project, Award Information

Project Group: ESSER III - Unfinished Learning

Project: APES0175, ESSER III - Unfinished Learning

Award: S425U210008 Award Year: 2021

Payee: PRINCE EDWARD CO PBLC SCHS

| Date       | Description     | Status            | Major Objects |            |            |            |      |      |      |      | Total      |
|------------|-----------------|-------------------|---------------|------------|------------|------------|------|------|------|------|------------|
|            |                 |                   | 0000          | 1000       | 2000       | 3000       | 4000 | 5000 | 6000 | 8000 |            |
| 02/01/2022 | Original Budget |                   | 935,409.87    | 0.00       | 0.00       | 0.00       | 0.00 | 0.00 | 0.00 | 0.00 | 935,409.87 |
| 02/16/2022 | Budget 421666   | Transfer Complete | -935,409.87   | 506,918.22 | 244,641.65 | 183,850.00 | 0.00 | 0.00 | 0.00 | 0.00 | 0.00       |
| 12/02/2022 | Reimb 454253    | Paid              | 0.00          | 0.00       | 0.00       | -10,500.00 | 0.00 | 0.00 | 0.00 | 0.00 | -10,500.00 |
| 03/03/2023 | Reimb 459321    | Paid              | 0.00          | 0.00       | 0.00       | -5,890.00  | 0.00 | 0.00 | 0.00 | 0.00 | -5,890.00  |
|            | Current Balance |                   | 0.00          | 506,918.22 | 244,641.65 | 167,460.00 | 0.00 | 0.00 | 0.00 | 0.00 | 919,019.87 |

Spend Down Calendar

| Target Date | Target Expenditures | Calculated Expenditures | Difference | Target Percentage | Calculated Percentage | Difference |
|-------------|---------------------|-------------------------|------------|-------------------|-----------------------|------------|
|-------------|---------------------|-------------------------|------------|-------------------|-----------------------|------------|

[Back](#)



Online Management of Education Grant Awards (OMEGA)

- OMEGA SUPPORT
- HELP
- PRINT
- LOGOUT

Current User: Amy McClure

Current Subrecipient: 00073 - PRINCE EDWARD CO PBLC SCHS

I want to... (Select One) Go

[SSWS Home](#)

[OMEGA Home](#)

[Logout](#)

### Spend Down Report

Selected Project Group, Project, Award Information

Project Group: ARP ESSER III

Project: DOE86834, Educator Recruitment and Retention - TEAL

Award: S425U210008 Award Year: 2021

Payee: PRINCE EDWARD CO PBLC SCHS

| Date       | Description     | Status            | Major Objects |      |      |            |      |      |      |      | Total      |
|------------|-----------------|-------------------|---------------|------|------|------------|------|------|------|------|------------|
|            |                 |                   | 0000          | 1000 | 2000 | 3000       | 4000 | 5000 | 6000 | 8000 |            |
| 02/01/2022 | Original Budget |                   | 100,000.00    | 0.00 | 0.00 | 0.00       | 0.00 | 0.00 | 0.00 | 0.00 | 100,000.00 |
| 02/14/2023 | Budget 460071   | Transfer Complete | -100,000.00   | 0.00 | 0.00 | 100,000.00 | 0.00 | 0.00 | 0.00 | 0.00 | 0.00       |
| 03/03/2023 | Reimb 459604    | Paid              | 0.00          | 0.00 | 0.00 | -3,105.00  | 0.00 | 0.00 | 0.00 | 0.00 | -3,105.00  |
|            | Current Balance |                   | 0.00          | 0.00 | 0.00 | 96,895.00  | 0.00 | 0.00 | 0.00 | 0.00 | 96,895.00  |

Spend Down Calendar

| Target Date | Target Expenditures | Calculated Expenditures | Difference | Target Percentage | Calculated Percentage | Difference |
|-------------|---------------------|-------------------------|------------|-------------------|-----------------------|------------|
|-------------|---------------------|-------------------------|------------|-------------------|-----------------------|------------|

[Back](#)



Online Management of Education Grant Awards (OMEGA)

- OMEGA SUPPORT
- HELP
- PRINT
- LOGOUT

Current User: Amy McClure

Current Subrecipient: 00073 - PRINCE EDWARD CO PBLC SCHS

I want to... (Select One) Go

[SSWS Home](#)

[OMEGA Home](#)

[Logout](#)

### Spend Down Report

Selected Project Group, Project, Award Information

Project Group: ESSER III - Before And After School

Project: APE50183, ESSER III - Before and After School

Award: S425U210008 Award Year:2021

Payee: PRINCE EDWARD CO PBLC SCHS

| Date       | Description     | Status            | Major Objects |            |          |           |           |          |           |      | Total |            |
|------------|-----------------|-------------------|---------------|------------|----------|-----------|-----------|----------|-----------|------|-------|------------|
|            |                 |                   | 0000          | 1000       | 2000     | 3000      | 4000      | 5000     | 6000      | 8000 |       |            |
| 02/01/2022 | Original Budget |                   | 179,167.13    | 0.00       | 0.00     | 0.00      | 0.00      | 0.00     | 0.00      | 0.00 | 0.00  | 179,167.13 |
| 02/16/2022 | Budget 421667   | Transfer Complete | -179,167.13   | 120,359.62 | 9,207.51 | 21,200.00 | 15,000.00 | 2,000.00 | 11,400.00 | 0.00 | 0.00  | 0.00       |
| 08/12/2022 | Reimb 439352    | Paid              | 0.00          | 0.00       | 0.00     | 0.00      | -422.39   | 0.00     | -3,858.05 | 0.00 | 0.00  | -4,280.44  |
| 09/30/2022 | Reimb 445229    | Paid              | 0.00          | 0.00       | 0.00     | -90.00    | 0.00      | -226.40  | 0.00      | 0.00 | 0.00  | -316.40    |
| 03/17/2023 | Reimb 459448    | Paid              | 0.00          | 0.00       | 0.00     | -7,306.02 | 0.00      | 0.00     | 0.00      | 0.00 | 0.00  | -7,306.02  |
|            | Current Balance |                   | 0.00          | 120,359.62 | 9,207.51 | 13,803.98 | 14,577.61 | 1,773.60 | 7,541.95  | 0.00 | 0.00  | 167,264.27 |

Spend Down Calendar

| Target Date | Target Expenditures | Calculated Expenditures | Difference | Target Percentage | Calculated Percentage | Difference |
|-------------|---------------------|-------------------------|------------|-------------------|-----------------------|------------|
|-------------|---------------------|-------------------------|------------|-------------------|-----------------------|------------|

[Back](#)



Online Management of Education Grant Awards (OMEGA)

- OMEGA SUPPORT
- HELP
- PRINT
- LOGOUT

Current User: Amy McClure

Current Subrecipient: 00073 - PRINCE EDWARD CO PBLC SCHS

I want to... (Select One) Go

[SSWS Home](#)

[OMEGA Home](#)

[Logout](#)

### Spend Down Report

Selected Project Group, Project, Award Information

Project Group: ARP ESSER III

Project: APE50193, ESSER III Division Allocations

Award: S425U210008 Award Year:2021

Payee: PRINCE EDWARD CO PBLC SCHS

| Date       | Description     | Status            | Major Objects |             |            |              |           |           |              |              | Total        |              |
|------------|-----------------|-------------------|---------------|-------------|------------|--------------|-----------|-----------|--------------|--------------|--------------|--------------|
|            |                 |                   | 0000          | 1000        | 2000       | 3000         | 4000      | 5000      | 6000         | 8000         |              |              |
| 11/01/2021 | Original Budget |                   | 7,064,263.73  | 0.00        | 0.00       | 0.00         | 0.00      | 0.00      | 0.00         | 0.00         | 0.00         | 7,064,263.73 |
| 10/25/2021 | Budget 410661   | Transfer Complete | -4,706,166.87 | 564,000.00  | 60,473.25  | 917,315.19   | 25,000.00 | 20,000.00 | 912,243.33   | 2,207,135.10 | 0.00         | 0.00         |
| 01/07/2022 | Reimb 414405    | Paid              | 0.00          | -14,694.68  | -1,124.15  | 0.00         | 0.00      | 0.00      | 0.00         | 0.00         | 0.00         | -15,818.83   |
| 01/17/2022 | Reimb 417382    | Paid              | 0.00          | 0.00        | 0.00       | -5,770.30    | 0.00      | 0.00      | -13,878.56   | -315,615.00  | -335,263.86  | 0.00         |
| 02/09/2022 | Budget 420881   | Transfer Complete | -2,358,096.86 | 888,514.10  | 293,066.26 | 928,496.37   | 25,000.00 | 40,000.00 | 256,666.67   | -73,646.54   | 0.00         | 0.00         |
| 03/11/2022 | Reimb 422794    | Paid              | 0.00          | 0.00        | 0.00       | -28,218.09   | 0.00      | 0.00      | 0.00         | -120,258.50  | -148,476.59  | 0.00         |
| 04/08/2022 | Reimb 425713    | Paid              | 0.00          | 0.00        | 0.00       | -9,801.42    | 0.00      | 0.00      | 0.00         | 0.00         | -9,801.42    | 0.00         |
| 04/15/2022 | Reimb 425655    | Paid              | 0.00          | -489,662.33 | -36,425.17 | -21,506.80   | 0.00      | 0.00      | 0.00         | 0.00         | 0.00         | -547,594.30  |
| 05/13/2022 | Reimb 429564    | Paid              | 0.00          | 0.00        | 0.00       | -8,500.00    | 0.00      | 0.00      | -64,470.36   | 0.00         | -72,970.36   | 0.00         |
| 05/20/2022 | Reimb 430291    | Paid              | 0.00          | -64,322.78  | -4,920.69  | 0.00         | 0.00      | 0.00      | 0.00         | 0.00         | -69,243.47   | 0.00         |
| 08/12/2022 | Reimb 439341    | Paid              | 0.00          | 0.00        | 0.00       | -58,842.86   | 0.00      | 0.00      | -7,123.10    | -21,477.00   | -87,442.96   | 0.00         |
| 09/16/2022 | Reimb 444839    | Paid              | 0.00          | 0.00        | 0.00       | -705.07      | 0.00      | 0.00      | 0.00         | 0.00         | -705.07      | 0.00         |
| 11/04/2022 | Reimb 450646    | Paid              | 0.00          | 0.00        | 0.00       | -99,769.00   | 0.00      | 0.00      | 0.00         | 0.00         | -99,769.00   | 0.00         |
| 12/09/2022 | Reimb 454259    | Paid              | 0.00          | 0.00        | 0.00       | -23,819.71   | 0.00      | 0.00      | 0.00         | 0.00         | -23,819.71   | 0.00         |
| 02/17/2023 | Reimb 459495    | Paid              | 0.00          | 0.00        | 0.00       | -16,000.00   | 0.00      | 0.00      | 0.00         | 0.00         | -16,000.00   | 0.00         |
|            | Current Balance |                   | 0.00          | 883,834.31  | 311,069.50 | 1,572,878.31 | 50,000.00 | 60,000.00 | 1,083,437.98 | 1,676,138.06 | 5,637,358.16 | 0.00         |

Spend Down Calendar

| Target Date | Target Expenditures | Calculated Expenditures | Difference | Target Percentage | Calculated Percentage | Difference |
|-------------|---------------------|-------------------------|------------|-------------------|-----------------------|------------|
|-------------|---------------------|-------------------------|------------|-------------------|-----------------------|------------|

[Back](#)

**[This page intentionally left blank]**



**Board of Supervisors  
Agenda Summary**

**Meeting Date:** May 9, 2023  
**Item #:** 12  
**Department:** County Administration  
**Staff Contact:** Douglas P. Stanley  
**Agenda Item:** Department Updates

---

**SUMMARY:** The following department directors will be in attendance at the Board meeting to provide an update on their departments:

1. Department of Social Services – Kimberly Allen, Director
2. Economic Development & Tourism – Chelsey White, Director

**ATTACHMENTS:**

**RECOMMENDATIONS:**

|              |                    |               |                |
|--------------|--------------------|---------------|----------------|
| Motion _____ | Cooper-Jones _____ | Gilliam _____ | Pride _____    |
| Second _____ | Emert _____        | Jenkins _____ | Townsend _____ |
|              |                    | Jones _____   | Watson _____   |

**[This page intentionally left blank]**





**Board of Supervisors  
Agenda Summary**

**Meeting Date:** May 9, 2023  
**Item #:** 13  
**Department:** County Administration  
**Staff Contact:** Sarah Elam Puckett  
**Agenda Item:** Appointments

Authorize Advertising Vacancies: Listed below are the boards and commissions which have upcoming vacancies and/or expiring terms of office in June 2023. Also attached is a copy of a Citizen Volunteer Application.

| APPOINTMENT                                                                                                                             | TERM OF OFFICE | # OF VACANCIES           | CURRENTLY IN OFFICE            |
|-----------------------------------------------------------------------------------------------------------------------------------------|----------------|--------------------------|--------------------------------|
| Local Board of Building Code Appeals                                                                                                    | 5 Years        | 1                        | Parker Terry*                  |
| Poplar Hill Community Development Authority                                                                                             | 2 Years        | 2<br>(Citizen Positions) | John Gantt *<br>Roy R. Yeatts* |
| County Industrial Development Authority                                                                                                 | 4 Years        | 1                        | Edgar Jones *<br>Joyce Yeatts* |
| Social Services Board<br><i>(Position to be filled by resident living in the Hampden-Sydney/Darlington Heights area of the County.)</i> | 4 Years        | 1                        | Karen Schinabeck*              |
| Central Virginia Regional Library Board                                                                                                 | 4 Years        | 1                        | Eunice Carwile                 |

*\*Eligible for re-appointment.*

**ATTACHMENTS:** Citizen Volunteer Application

**SAMPLE MOTION:** I move the Board authorize the advertisement of the Citizen Volunteer vacancies as outlined above for appointments at the June 13, 2023 Board meeting.

Motion \_\_\_\_\_ Cooper-Jones \_\_\_\_\_ Gilliam \_\_\_\_\_ Pride \_\_\_\_\_  
 Second \_\_\_\_\_ Emert \_\_\_\_\_ Jenkins \_\_\_\_\_ Townsend \_\_\_\_\_  
 Jones \_\_\_\_\_ Watson \_\_\_\_\_



## CITIZEN VOLUNTEER APPLICATION FOR COUNTY BOARDS, COMMITTEES & COMMISSIONS

Date \_\_\_\_\_

Name \_\_\_\_\_

Home Address \_\_\_\_\_

City \_\_\_\_\_ State \_\_\_\_\_ Zip Code \_\_\_\_\_

|                    |                     |                     |  |
|--------------------|---------------------|---------------------|--|
| Election District: | Buffalo-501 _____   | Farmville-801 _____ |  |
|                    | Hampden-401 _____   | Leigh-301 _____     |  |
|                    | Farmville-101 _____ | Lockett-201 _____   |  |
|                    | Farmville-701 _____ | Prospect-601 _____  |  |

Home Telephone Number \_\_\_\_\_ Mobile \_\_\_\_\_

E-Mail Address \_\_\_\_\_

Current Employer \_\_\_\_\_

Business Address \_\_\_\_\_

City \_\_\_\_\_ State \_\_\_\_\_ Zip Code \_\_\_\_\_

Business Telephone Number \_\_\_\_\_ FAX \_\_\_\_\_

Which Address is Preferred for Mailings? Home \_\_\_\_\_ Office \_\_\_\_\_

***Optional Information Which May Prove Helpful:***

Occupation \_\_\_\_\_

Former Occupation, If Retired \_\_\_\_\_

Education: High School \_\_\_\_\_ Year \_\_\_\_\_

College/Technical School \_\_\_\_\_ Year \_\_\_\_\_

Graduate School \_\_\_\_\_ Year \_\_\_\_\_

Military Service \_\_\_\_\_ Years \_\_\_\_\_

Degrees/Other \_\_\_\_\_

Past Board, Commission, and Committee Assignments \_\_\_\_\_

Professional, Civic, or Other Activities \_\_\_\_\_

Please state below your interest and/or reason to seek appointment by the Board of Supervisors and any special qualities that qualify you for this appointment.

---

---

---

---

---

Do you have a family member who is employed by the county office, organization or institution over which the Board/Commission for which you are seeking appointment will oversee/interact? If yes, please explain.

---

---

Do you have a business relationship with the county office, organization or institution over which the Board/Commission for which you are seeking appointment will oversee/interact?

---

---

---

I am interested in and willing to serve on the following Board(s), Commission(s), or Committee(s). Please list in order of preference.

**APPOINTED BY THE BOARD OF SUPERVISOR:**

- \_\_\_\_\_ Board of Appeals for Building Code
- \_\_\_\_\_ Southside Virginia Community College Board
- \_\_\_\_\_ Crossroads Community Services Board
- \_\_\_\_\_ Poplar Hill Community Development Authority
- \_\_\_\_\_ Prince Edward County Industrial Development Authority
- \_\_\_\_\_ Central Virginia Regional Library Board
- \_\_\_\_\_ Prince Edward County Planning Commission
- \_\_\_\_\_ Prince Edward County Social Services Board
- \_\_\_\_\_ Piedmont Regional Jail Board
- \_\_\_\_\_ Special Committee of the Board of Supervisors: \_\_\_\_\_
- \_\_\_\_\_ Other \_\_\_\_\_
- \_\_\_\_\_ Other \_\_\_\_\_
- \_\_\_\_\_ Other \_\_\_\_\_

**APPOINTED BY CIRCUIT COURT:**

- \_\_\_\_\_ Board of Zoning Appeals

*By submitting this application to the County of Prince Edward, I hereby certify that all information contained herein is true and complete and I consent to the dissemination of this document to the general public. If appointed, I understand that I will be required to fully comply to the requirements of the Virginia Conflict of Interest Act, Virginia Freedom of Information Act and other applicable sections of the Code of Virginia.*

\_\_\_\_\_  
Signature Date

**Please Return Application To:**  
Prince Edward County Administrator's Office  
Post Office Box 382, 111 South Street, 3<sup>rd</sup> Floor  
Farmville, Virginia 23901  
Tel: 434-392-8837 -- FAX: 434-392-6683  
e-mail: [info@co.prince-edward.va.us](mailto:info@co.prince-edward.va.us)

NOTE: This application will be retained on file in the Prince Edward County Administrator's Office through December 31 of the year submitted. If you wish to be considered for future appointments by the Board of Supervisors, please file an application annually with the County Administrator's Office. Thank you.

**[This page intentionally left blank]**